



# PCAL9538A

Low-voltage 8-bit I<sup>2</sup>C-bus and SMBus low power I/O port with interrupt, reset and Agile I/O

Rev. 3.1 — 27 May 2015

Product data sheet

## 1. General description

The PCAL9538A is a low-voltage 8-bit General Purpose Input/Output (GPIO) expander with interrupt and reset for I<sup>2</sup>C-bus/SMBus applications. NXP I/O expanders provide a simple solution when additional I/Os are needed while keeping interconnections to a minimum, for example, in ACPI power switches, sensors, push buttons, LEDs, fan control, etc.

In addition to providing a flexible set of GPIOs, the wide V<sub>DD</sub> range of 1.65 V to 5.5 V allows the PCAL9538A to interface with next-generation microprocessors and microcontrollers where supply levels are dropping down to conserve power.

The PCAL9538A contains the PCA9538A register set of four 8-bit Configuration, Input, Output, and Polarity Inversion registers, and additionally, the PCAL9538A has Agile I/O, which are additional features specifically designed to enhance the I/O. These additional features are: programmable output drive strength, latchable inputs, programmable pull-up/pull-down resistors, maskable interrupt, interrupt status register, programmable open-drain or push-pull outputs.

The PCAL9538A is a pin-to-pin replacement for the PCA9538, however, the PCAL9538A powers up with all I/O interrupts masked. This mask default allows for a board bring-up free of spurious interrupts at power-up.

The PCAL9538A open-drain interrupt ( $\overline{\text{INT}}$ ) output is activated when any input state differs from its corresponding Input Port register state and is used to indicate to the system master that an input state has changed.

$\overline{\text{INT}}$  can be connected to the interrupt input of a microcontroller. By sending an interrupt signal on this line, the remote I/O can inform the microcontroller if there is incoming data on its ports without having to communicate via the I<sup>2</sup>C-bus. Thus, the PCAL9538A can remain a simple slave device.

The device outputs have 25 mA sink capabilities for directly driving LEDs while consuming low device current.

The power-on reset sets the registers to their default values and initializes the device state machine. In the PCAL9538A, the  $\overline{\text{RESET}}$  pin causes the same reset/default I/O input configuration to occur without de-powering the device, holding the registers and I<sup>2</sup>C-bus state machine in their default state until the  $\overline{\text{RESET}}$  input is once again HIGH. This input requires a pull-up to V<sub>DD</sub>.

Two hardware pins (A0, A1) select the fixed I<sup>2</sup>C-bus address and allow up to four devices to share the same I<sup>2</sup>C-bus/SMBus.



## 2. Features and benefits

- I<sup>2</sup>C-bus to parallel port expander
- Operating power supply voltage range of 1.65 V to 5.5 V
- Low standby current consumption:
  - ◆ 1.5  $\mu$ A (typical at 5 V  $V_{DD}$ )
  - ◆ 1.0  $\mu$ A (typical at 3.3 V  $V_{DD}$ )
- Schmitt-trigger action allows slow input transition and better switching noise immunity at the SCL and SDA inputs
  - ◆  $V_{hys} = 0.10 \times V_{DD}$  (typical)
- 5 V tolerant I/Os
- Active LOW reset input ( $\overline{RESET}$ )
- Open-drain active LOW interrupt output ( $\overline{INT}$ )
- 400 kHz Fast-mode I<sup>2</sup>C-bus
- Internal power-on reset
- Power-up with all channels configured as inputs
- No glitch on power-up
- Latched outputs with 25 mA drive maximum capability for directly driving LEDs
- Latch-up performance exceeds 100 mA per JESD78, Class II
- ESD protection exceeds JESD22
  - ◆ 2000 V Human Body Model (A114-A)
  - ◆ 1000 V Charged-Device Model (C101)
- Packages offered: TSSOP16 and HVQFN16

### 2.1 Agile I/O features

- Pin to pin replacement for PCA9538 and PCA9538A with interrupts disabled at power-up
  - ◆ Software backward compatible with PCA9538 and PCA9538A
- Output port configuration: bank selectable push-pull or open-drain output stages
- Interrupt status: read-only register identifies the source of an interrupt
- Bit-wise I/O programming features:
  - ◆ Output drive strength: four programmable drive strengths to reduce rise and fall times in low capacitance applications
  - ◆ Input latch: Input Port register values changes are kept until the Input Port register is read
  - ◆ Pull-up/pull-down enable: floating input or pull-up/down resistor enable
  - ◆ Pull-up/pull-down selection: 100 k $\Omega$  pull-up/down resistor selection
  - ◆ Interrupt mask: mask prevents the generation of the interrupt when input changes state

### 3. Ordering information

Table 1. Ordering information

Type number	Topside mark	Package		Version
		Name	Description	
PCAL9538ABS	L3A	HVQFN16	plastic thermal enhanced very thin quad flat package; no leads; 16 terminals; body 3 × 3 × 0.85 mm	SOT758-1
PCAL9538APW	PL9538A	TSSOP16	plastic thin shrink small outline package; 16 leads; body width 4.4 mm	SOT403-1

#### 3.1 Ordering options

Table 2. Ordering options

Type number	Orderable part number	Package	Packing method	Minimum order quantity	Temperature range
PCAL9538ABS	PCAL9538ABSHP	HVQFN16	Reel 13" Q2/T3 *Standard mark SMD	6000	T <sub>amb</sub> = -40 °C to +85 °C
PCAL9538APW	PCAL9538APWJ	TSSOP16	Reel 13" Q1/T1 *Standard mark SMD	2500	T <sub>amb</sub> = -40 °C to +85 °C

### 4. Block diagram

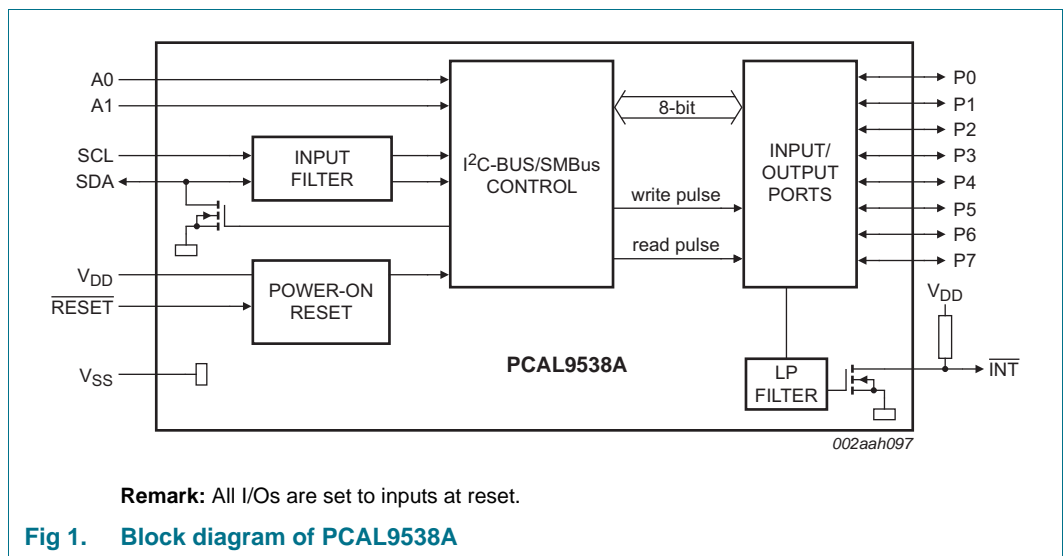

Fig 1. Block diagram of PCAL9538A

## 5. Pinning information

### 5.1 Pinning

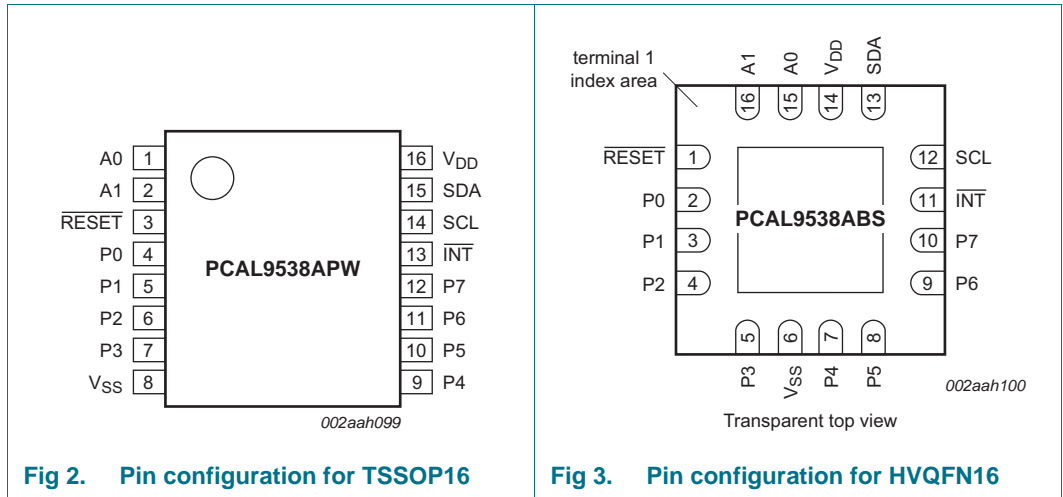

Fig 2. Pin configuration for TSSOP16

Fig 3. Pin configuration for HVQFN16

### 5.2 Pin description

Table 3. Pin description

Symbol	Pin		Description
	TSSOP16	HVQFN16	
A0	1	15	address input 0
A1	2	16	address input 1
RESET	3	1	active LOW reset input
P0 <sup>[1]</sup>	4	2	Port P input/output 0
P1 <sup>[1]</sup>	5	3	Port P input/output 1
P2 <sup>[1]</sup>	6	4	Port P input/output 2
P3 <sup>[1]</sup>	7	5	Port P input/output 3
V <sub>SS</sub>	8	6 <sup>[2]</sup>	supply ground
P4 <sup>[1]</sup>	9	7	Port P input/output 4
P5 <sup>[1]</sup>	10	8	Port P input/output 5
P6 <sup>[1]</sup>	11	9	Port P input/output 6
P7 <sup>[1]</sup>	12	10	Port P input/output 7
INT	13	11	interrupt output (open-drain)
SCL	14	12	serial clock line
SDA	15	13	serial data line
V <sub>DD</sub>	16	14	supply voltage

[1] All I/O are configured as input at power-on.

[2] HVQFN16 package die supply ground is connected to both the V<sub>SS</sub> pin and the exposed center pad. The V<sub>SS</sub> pin must be connected to supply ground for proper device operation. For enhanced thermal, electrical, and board-level performance, the exposed pad needs to be soldered to the board using a corresponding thermal pad on the board, and for proper heat conduction through the board thermal vias need to be incorporated in the printed-circuit board in the thermal pad region.

## 6. Functional description

Refer to [Figure 1 “Block diagram of PCAL9538A”](#).

### 6.1 Device address

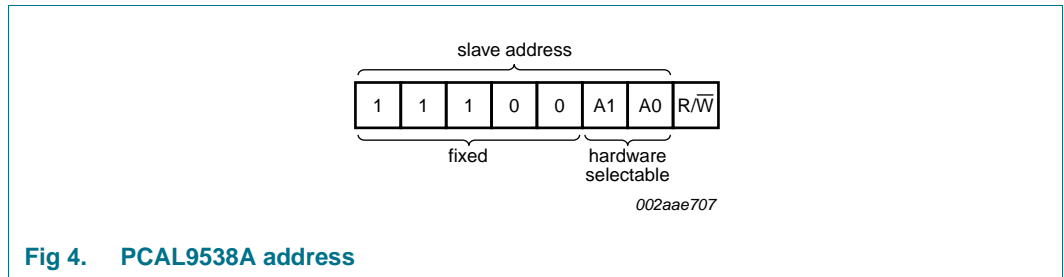

A1 and A0 are the hardware address package pins and are held to either HIGH (logic 1) or LOW (logic 0) to assign one of the four possible slave addresses. The last bit of the slave address (R/W) defines the operation (read or write) to be performed. A HIGH (logic 1) selects a read operation, while a LOW (logic 0) selects a write operation.

### 6.2 Pointer register and command byte

Following the successful acknowledgement of the address byte, the bus master sends a command byte, which is stored in the Pointer register in the PCAL9538A. Two bits of this data byte state the operation (read or write) and the internal registers (Input, Output, Polarity Inversion, or Configuration) that will be affected. Bit 6 in conjunction with the lower three bits of the Command byte are used to point to the extended features of the device (Agile I/O). This register is write only.

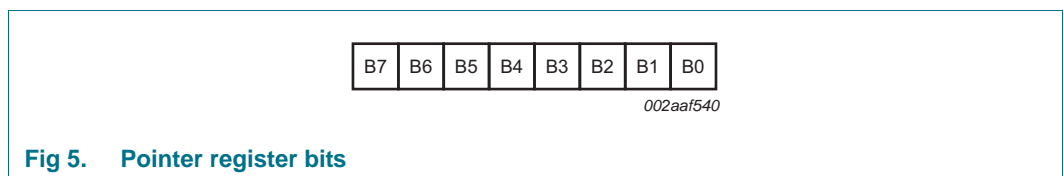

Table 4. Command byte

Pointer register bits								Command byte (hexadecimal)	Register	Protocol	Power-up default
B7	B6	B5	B4	B3	B2	B1	B0				
0	0	0	0	0	0	0	0	00h	Input port	read byte	xxxx xxxx <sup>[1]</sup>
0	0	0	0	0	0	0	1	01h	Output port	read/write byte	1111 1111
0	0	0	0	0	0	1	0	02h	Polarity Inversion	read/write byte	0000 0000
0	0	0	0	0	0	1	1	03h	Configuration	read/write byte	1111 1111
0	1	0	0	0	0	0	0	40h	Output drive strength 0	read/write byte	1111 1111
0	1	0	0	0	0	0	1	41h	Output drive strength 1	read/write byte	1111 1111
0	1	0	0	0	0	1	0	42h	Input latch	read/write byte	0000 0000
0	1	0	0	0	0	1	1	43h	Pull-up/pull-down enable	read/write byte	0000 0000
0	1	0	0	0	1	0	0	44h	Pull-up/pull-down selection	read/write byte	1111 1111
0	1	0	0	0	1	0	1	45h	Interrupt mask	read/write byte	1111 1111
0	1	0	0	0	1	1	0	46h	Interrupt status	read byte	0000 0000
0	1	0	0	1	1	1	1	4Fh	Output port configuration	read/write byte	0000 0000

[1] Undefined.

### 6.3 Interface definition

Table 5. Interface definition

Byte	Bit							
	7 (MSB)	6	5	4	3	2	1	0 (LSB)
I <sup>2</sup> C-bus slave address	H	H	H	L	L	A1	A0	R/ $\bar{W}$
I/O data bus	P7	P6	P5	P4	P3	P2	P1	P0

### 6.4 Register descriptions

#### 6.4.1 Input port register (00h)

The Input port register (register 0) reflects the incoming logic levels of the pins, regardless of whether the pin is defined as an input or an output by the Configuration register. The Input port register is read only; writes to this register have no effect. The default value 'X' is determined by the externally applied logic level. An Input port register read operation is performed as described in [Section 7.2 "Read commands"](#).

Table 6. Input port register (address 00h)

Bit	7	6	5	4	3	2	1	0
Symbol	I7	I6	I5	I4	I3	I2	I1	I0
Default	X	X	X	X	X	X	X	X

#### 6.4.2 Output port register (01h)

The Output port register (register 1) shows the outgoing logic levels of the pins defined as outputs by the Configuration register. Bit values in these registers have no effect on pins defined as inputs. In turn, reads from this register reflect the value that was written to this register, **not** the actual pin value.

Table 7. Output port register (address 01h)

Bit	7	6	5	4	3	2	1	0
Symbol	O7	O6	O5	O4	O3	O2	O1	O0
Default	1	1	1	1	1	1	1	1

### 6.4.3 Polarity inversion register (02h)

The Polarity inversion register (register 2) allows polarity inversion of pins defined as inputs by the Configuration register. If a bit in this register is set (written with '1'), the corresponding port pin's polarity is inverted. If a bit in this register is cleared (written with a '0'), the corresponding port pin's original polarity is retained.

Table 8. Polarity inversion register (address 02h)

Bit	7	6	5	4	3	2	1	0
Symbol	N7	N6	N5	N4	N3	N2	N1	N0
Default	0	0	0	0	0	0	0	0

### 6.4.4 Configuration register (03h)

The Configuration register (register 3) configures the direction of the I/O pins. If a bit in this register is set to 1, the corresponding port pin is enabled as a high-impedance input. If a bit in this register is cleared to 0, the corresponding port pin is enabled as an output.

Table 9. Configuration register (address 03h)

Bit	7	6	5	4	3	2	1	0
Symbol	C7	C6	C5	C4	C3	C2	C1	C0
Default	1	1	1	1	1	1	1	1

### 6.4.5 Output drive strength registers (40h, 41h)

The Output drive strength registers control the output drive level of the GPIO. Each GPIO can be configured independently to a certain output current level by two register control bits. For example, Port 7 is controlled by register 41 CC7 (bits [7:6]), Port 6 is controlled by register 41 CC6 (bits [5:4]). The output drive level of the GPIO is programmed 00b = 0.25×, 01b = 0.5×, 10b = 0.75× or 11b = 1× of the drive capability of the I/O. See [Section 8.2 "Output drive strength control"](#) for more details.

Table 10. Current control register (address 40h)

Bit	7	6	5	4	3	2	1	0
Symbol	CC3		CC2		CC1		CC0	
Default	1	1	1	1	1	1	1	1

Table 11. Current control register (address 41h)

Bit	7	6	5	4	3	2	1	0
Symbol	CC7		CC6		CC5		CC4	
Default	1	1	1	1	1	1	1	1

### 6.4.6 Input latch register (42h)

The Input latch register enables and disables the input latch of the I/O pins. These registers are effective only when the pin is configured as an input port. When an input latch register bit is 0, the corresponding input pin state is not latched. A state change in the corresponding input pin generates an interrupt. A read of the input port register clears the interrupt. If the input goes back to its initial logic state before the input port register is read, then the interrupt is cleared.

When an input latch register bit is 1, the corresponding input pin state is latched. A change of state of the input generates an interrupt and the input logic value is loaded into the corresponding bit of the input port register (registers 0). A read of the input port register clears the interrupt. If the input pin returns to its initial logic state before the input port register is read, then the interrupt is not cleared and the corresponding bit of the input port register keeps the logic value that initiated the interrupt. See [Figure 11](#). For example, if the P4 input was as logic 0 and the input goes to logic 1 then back to logic 0, the input port register will capture this change and an interrupt is generated (if unmasked). When the read is performed on the input port register, the interrupt is cleared, assuming there were no additional input(s) that have changed, and bit 4 of the input port register will read '1'. The next read of the input port register bit 4 should now read '0'.

An interrupt remains active when a non-latched input simultaneously switches state with a latched input and then returns to its original state. A read of the input port register reflects only the change of state of the latched input and also clears the interrupt. The interrupt is not cleared if the input latch register changes from latched to non-latched configuration.

If the input pin is changed from latched to non-latched input, a read from the input port register reflects the current port logic level. If the input pin is changed from non-latched to latched input, the read from the input port register reflects the latched logic level.

**Table 12. Input latch register (address 42h)**

Bit	7	6	5	4	3	2	1	0
Symbol	L7	L6	L5	L4	L3	L2	L1	L0
Default	0	0	0	0	0	0	0	0

### 6.4.7 Pull-up/pull-down enable register (43h)

This register allows the user to enable or disable pull-up/pull-down resistors on the I/O pins. Setting the bit to logic 1 enables the selection of pull-up/pull-down resistors. Setting the bit to logic 0 disconnects the pull-up/pull-down resistors from the I/O pins. Use the pull-up/pull-down registers to select either a pull-up or pull-down resistor.

**Table 13. Pull-up/pull-down enable register (address 43h)**

Bit	7	6	5	4	3	2	1	0
Symbol	PE7	PE6	PE5	PE4	PE3	PE2	PE1	PE0
Default	0	0	0	0	0	0	0	0

**6.4.8 Pull-up/pull-down selection register (44h)**

The I/O port can be configured to have pull-up or pull-down resistor by programming the pull-up/pull-down selection register. Setting a bit to logic 1 selects a 100 kΩ pull-up resistor for that I/O pin. Setting a bit to logic 0 selects a 100 kΩ pull-down resistor for that I/O pin. If the pull-up/down feature is disconnected, writing to this register will have no effect on I/O pin. Typical value is 100 kΩ with minimum of 50 kΩ and maximum of 150 kΩ.

**Table 14. Pull-up/pull-down selection register (address 44h)**

Bit	7	6	5	4	3	2	1	0
Symbol	PUD7	PUD6	PUD5	PUD4	PUD3	PUD2	PUD1	PUD0
Default	1	1	1	1	1	1	1	1

**6.4.9 Interrupt mask register (45h)**

Interrupt mask register is set to logic 1 upon power-on, disabling interrupts during system start-up. Interrupts may be enabled by setting corresponding mask bits to logic 0. If an input changes state and the corresponding bit in the Interrupt mask register is set to 1, the interrupt is masked and the interrupt pin (INT) will not be asserted. If the corresponding bit in the Interrupt mask register is set to 0, the interrupt pin will be asserted.

When an input changes state and the resulting interrupt is masked (interrupt mask bit is 1), setting the input mask register bit to 0 will cause the interrupt pin to be asserted. If the interrupt mask bit of an input that is currently the source of an interrupt is set to 1, the interrupt pin will be de-asserted.

**Table 15. Interrupt mask register (address 45h)**

Bit	7	6	5	4	3	2	1	0
Symbol	M7	M6	M5	M4	M3	M2	M1	M0
Default	1	1	1	1	1	1	1	1

**6.4.10 Interrupt status register (46h)**

This read-only register is used to identify the source of an interrupt. When read, a logic 1 indicates that the corresponding input pin was the source of the interrupt. A logic 0 indicates that the input pin is not the source of an interrupt.

When a corresponding bit in the interrupt mask register is set to 1 (masked), the interrupt status bit will return logic 0.

**Table 16. Interrupt status register (address 46h)**

Bit	7	6	5	4	3	2	1	0
Symbol	S7	S6	S5	S4	S3	S2	S1	S0
Default	0	0	0	0	0	0	0	0

#### 6.4.11 Output port configuration register (4Fh)

The output port configuration register selects port-wise push-pull or open-drain I/O stage. A logic 0 configures the I/O as push-pull (Q1 and Q2 are active, see [Figure 6](#)). A logic 1 configures the I/O as open-drain (Q1 is disabled, Q2 is active). The recommended command sequence is to program this register (4Fh) before the Configuration register (03h) sets the port pins as outputs.

**Table 17. Output port configuration register (address 4Fh)**

Bit	7	6	5	4	3	2	1	0
Symbol	reserved							ODEN0
Default	0	0	0	0	0	0	0	0

### 6.5 I/O port

When an I/O is configured as an input, FETs Q1 and Q2 are off, which creates a high-impedance input. The input voltage may be raised above V<sub>DD</sub> to a maximum of 5.5 V.

If the I/O is configured as an output, Q1 or Q2 is enabled, depending on the state of the Output port register. In this case, there are low-impedance paths between the I/O pin and either V<sub>DD</sub> or V<sub>SS</sub>. The external voltage applied to this I/O pin should not exceed the recommended levels for proper operation.

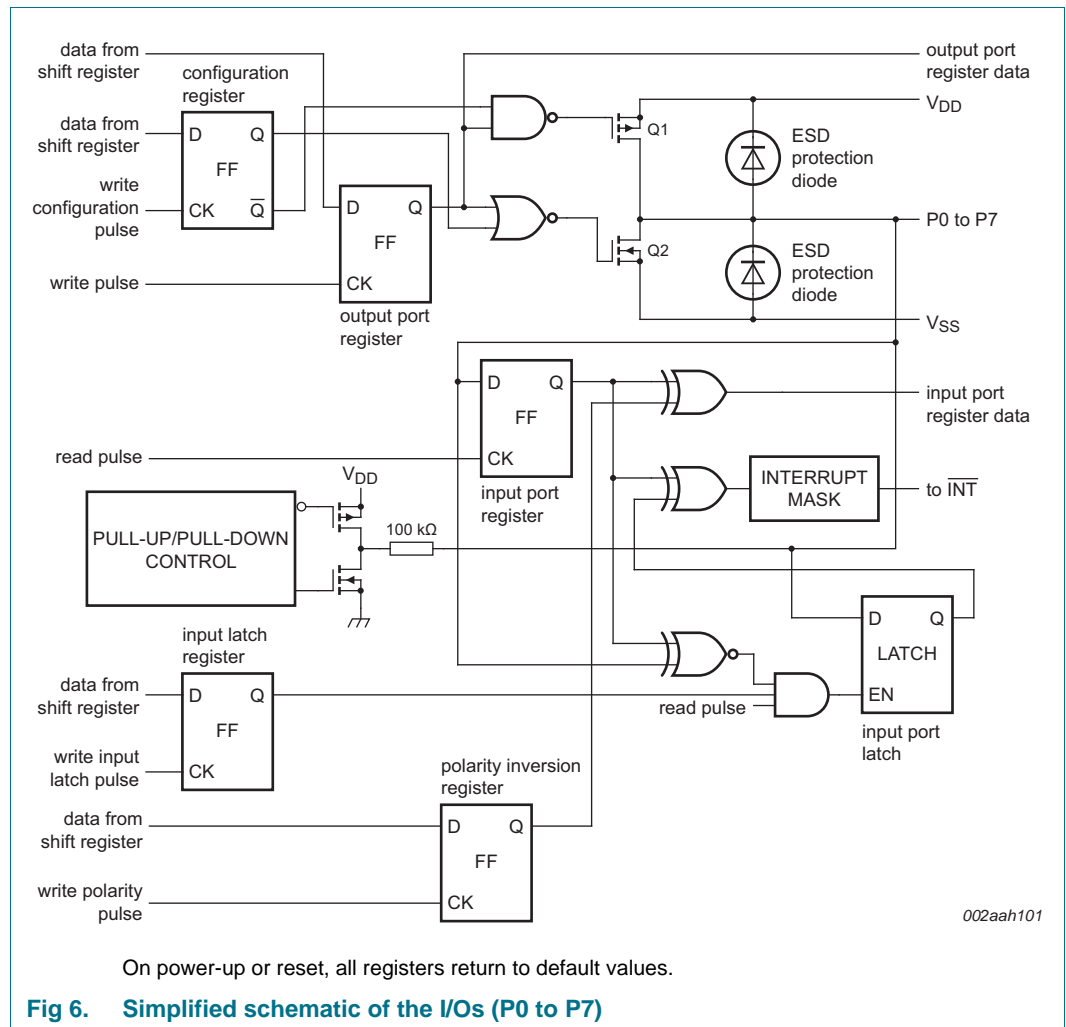

## 6.6 Power-on reset

When power (from 0 V) is applied to  $V_{DD}$ , an internal power-on reset holds the PCAL9538A in a reset condition until  $V_{DD}$  has reached  $V_{POR}$ . At that time, the reset condition is released and the PCAL9538A registers and I<sup>2</sup>C-bus/SMBus state machine initialize to their default states. After that,  $V_{DD}$  must be lowered to below  $V_{POR}$  and back up to the operating voltage for a power-reset cycle. See [Section 8.4 “Power-on reset requirements”](#).

## 6.7 Reset input ( $\overline{\text{RESET}}$ )

The  $\overline{\text{RESET}}$  input can be asserted to initialize the system while keeping the  $V_{DD}$  at its operating level. A reset can be accomplished by holding the  $\overline{\text{RESET}}$  pin LOW for a minimum of  $t_{w(\text{rst})}$ . The PCAL9538A registers and I<sup>2</sup>C-bus/SMBus state machine are changed to their default state once  $\overline{\text{RESET}}$  is LOW (0). When  $\overline{\text{RESET}}$  is HIGH (1), the I/O levels at the P port can be changed externally or through the master. This input requires a pull-up resistor to  $V_{DD}$  if no active connection is used.

## 6.8 Interrupt output ( $\overline{\text{INT}}$ )

An interrupt is generated by any rising or falling edge of the port inputs in the Input mode. After time  $t_{v(\text{INT})}$ , the signal  $\overline{\text{INT}}$  is valid. Resetting the interrupt circuit is achieved when data on the port is changed to the original setting or when data is read from the port that generated the interrupt (see [Figure 10](#)). Resetting occurs in the Read mode at the acknowledge (ACK) or not acknowledge (NACK) bit after the rising edge of the SCL signal. Interrupts that occur during the ACK or NACK clock pulse can be lost (or be very short) due to the resetting of the interrupt during this pulse. Each change of the I/Os after resetting is detected and is transmitted as  $\overline{\text{INT}}$ .

A pin configured as an output cannot cause an interrupt. Changing an I/O from an output to an input may cause a false interrupt to occur, if the state of the pin does not match the contents of the Input port register.

The  $\overline{\text{INT}}$  output has an open-drain structure and requires a pull-up resistor to  $V_{DD}$ .  $\overline{\text{INT}}$  should be connected to the voltage source of the device that requires the interrupt information. When using the input latch feature, the input pin state is latched. The interrupt is reset only when data is read from the port that generated the interrupt. The reset occurs in the Read mode at the acknowledge (ACK) or not acknowledge (NACK) bit after the rising edge of the SCL signal.

## 7. Bus transactions

The PCAL9538A is an I<sup>2</sup>C-bus slave device. Data is exchanged between the master and PCAL9538A through write and read commands using I<sup>2</sup>C-bus. The two communication lines are a serial data line (SDA) and a serial clock line (SCL). Both lines must be connected to a positive supply via a pull-up resistor when connected to the output stages of a device. Data transfer may be initiated only when the bus is not busy.

### 7.1 Write commands

Data is transmitted to the PCAL9538A by sending the device address and setting the Least Significant Bit (LSB) to a logic 0 (see Figure 4 for device address). The command byte is sent after the address and determines which register receives the data that follows the command byte. There is no limitation on the number of data bytes sent in one write transmission.

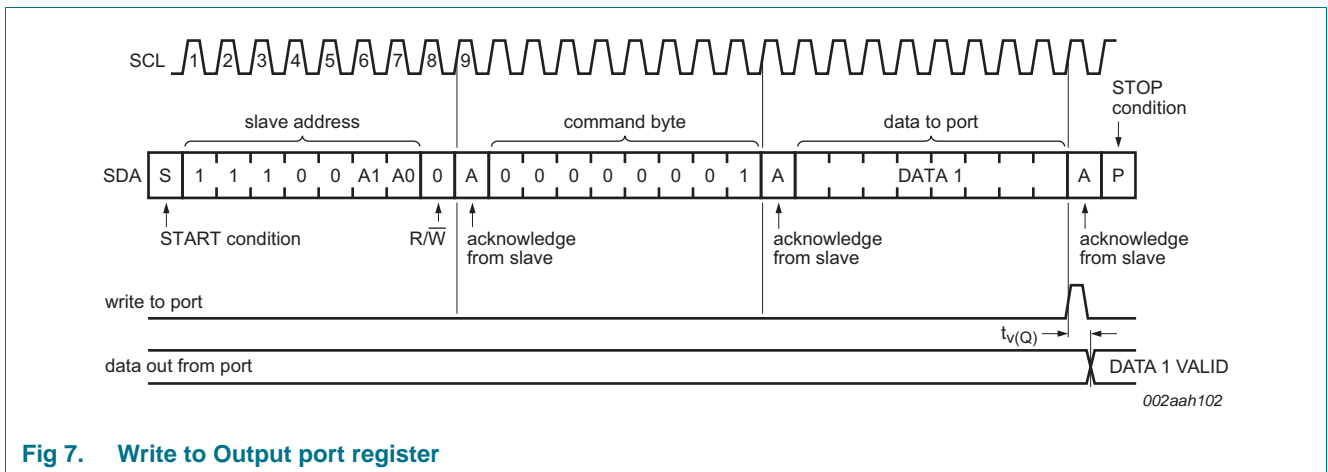

Fig 7. Write to Output port register

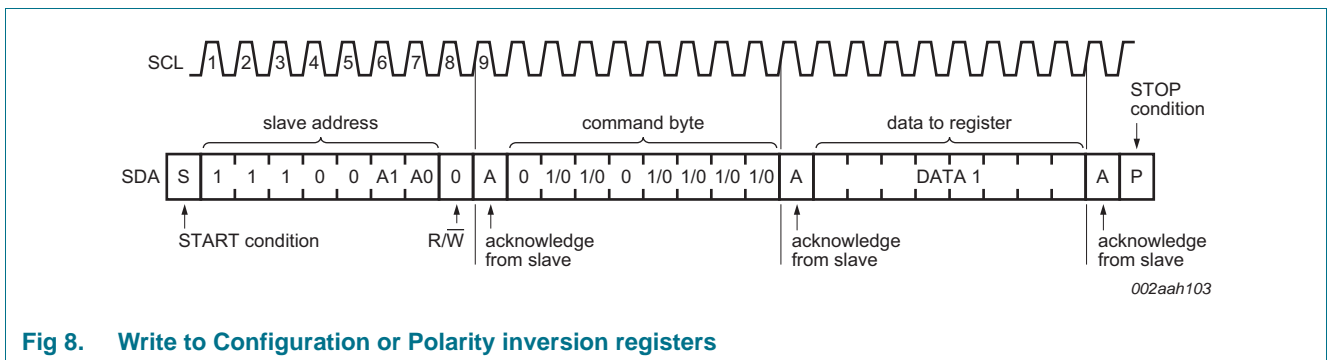

Fig 8. Write to Configuration or Polarity inversion registers

### 7.2 Read commands

To read data from the PCAL9538A, the bus master must first send the PCAL9538A address with the least significant bit set to a logic 0 (see Figure 4 for device address). The command byte is sent after the address and determines which register is to be accessed.

After a restart the device address is sent again, but this time the LSB is set to a logic 1. Data from the register defined by the command byte then is sent by the PCAL9538A (see Figure 9 and Figure 10).

Data is clocked into the register on the rising edge of the ACK clock pulse. There is no limit on the number of data bytes received in one read transmission, but on the final byte received the bus master must not acknowledge the data.

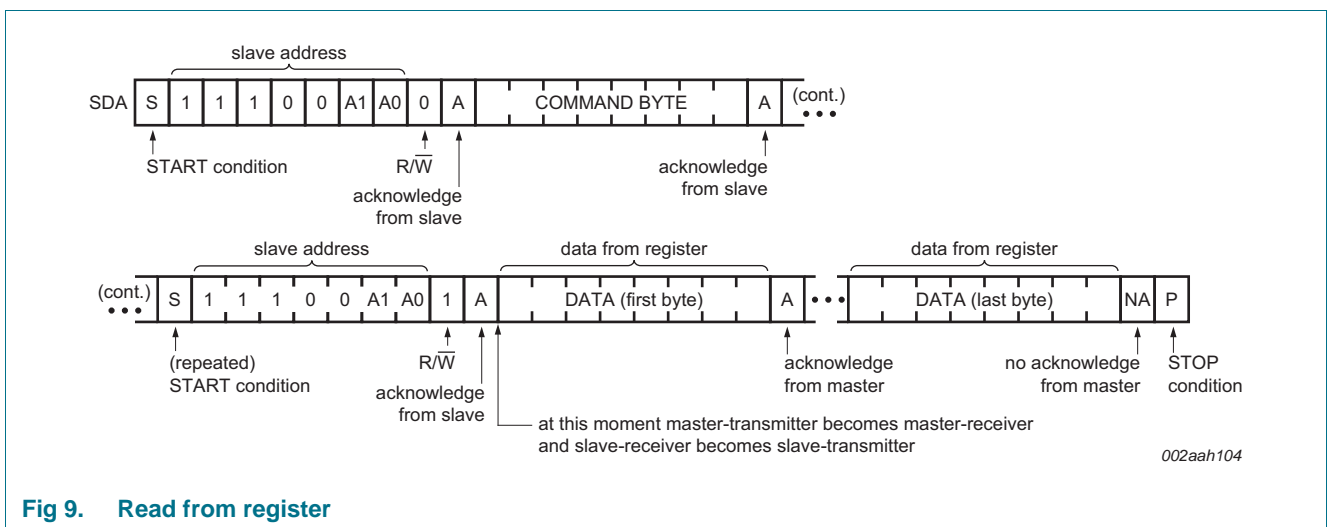
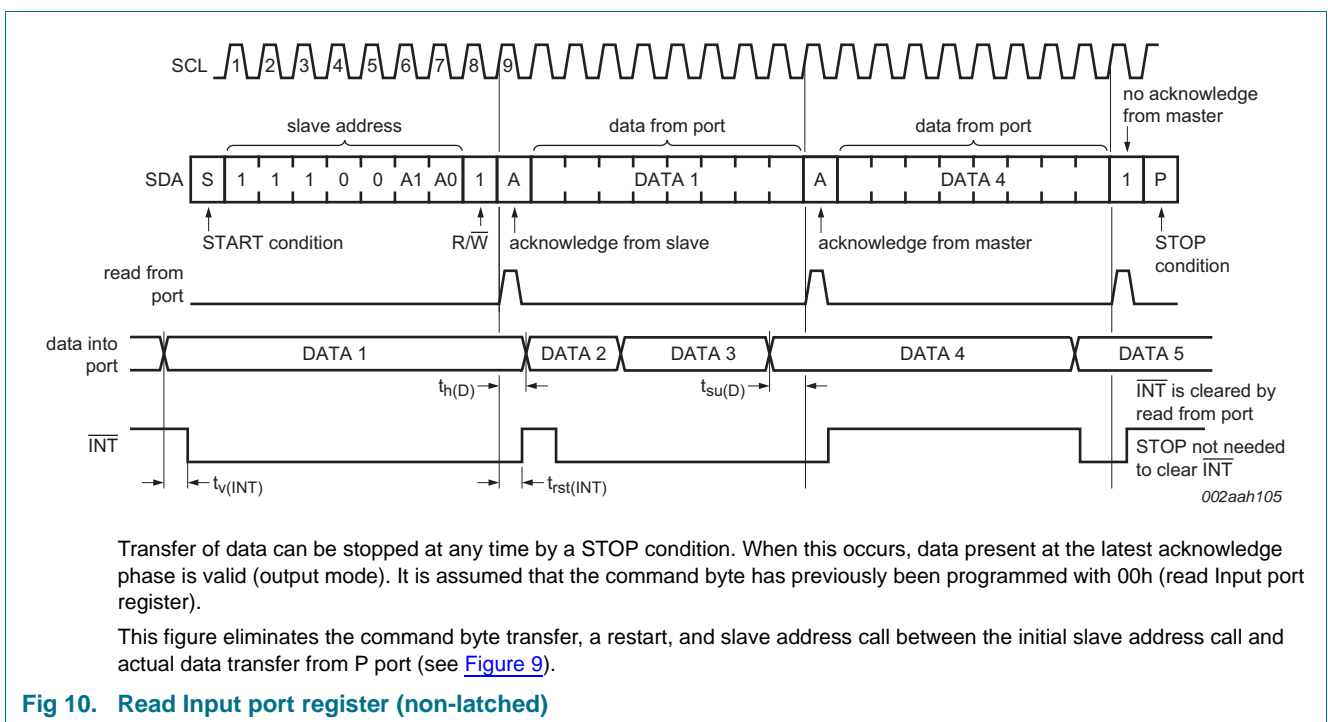

Fig 9. Read from register



Transfer of data can be stopped at any time by a STOP condition. When this occurs, data present at the latest acknowledge phase is valid (output mode). It is assumed that the command byte has previously been programmed with 00h (read Input port register).

This figure eliminates the command byte transfer, a restart, and slave address call between the initial slave address call and actual data transfer from P port (see Figure 9).

Fig 10. Read Input port register (non-latched)

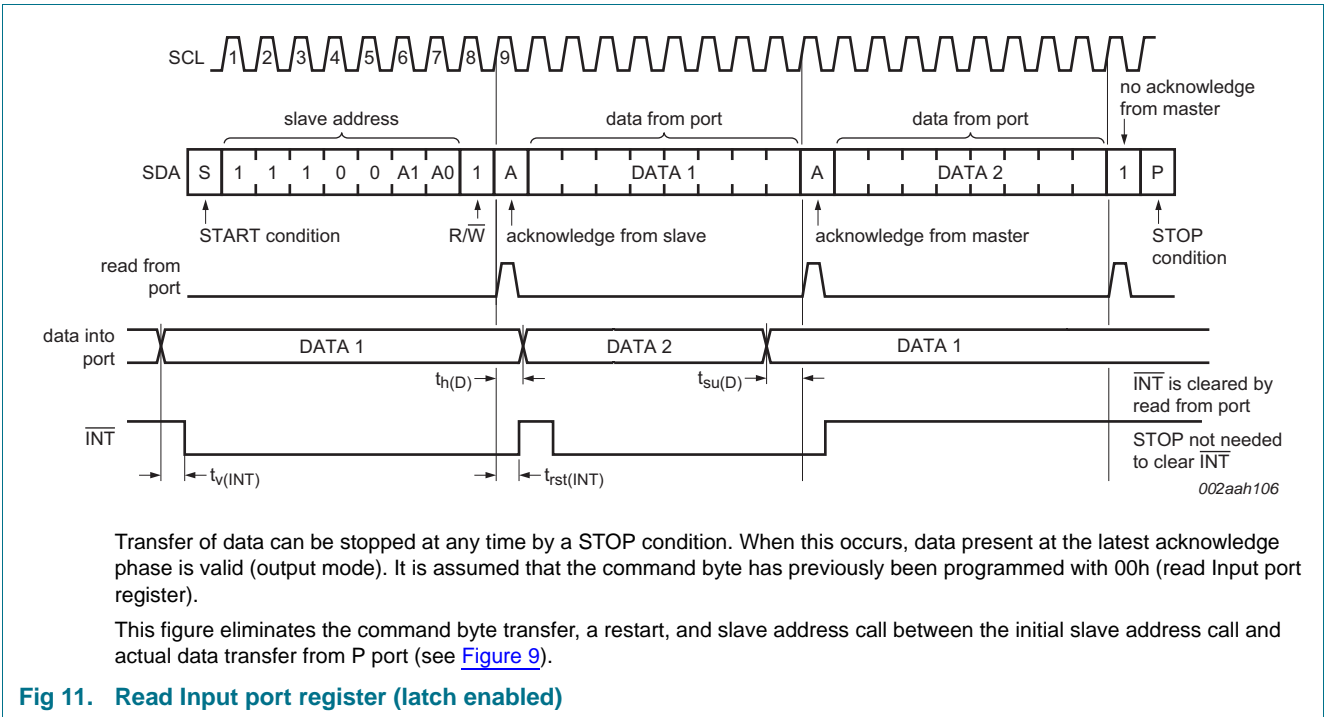

## 8. Application design-in information

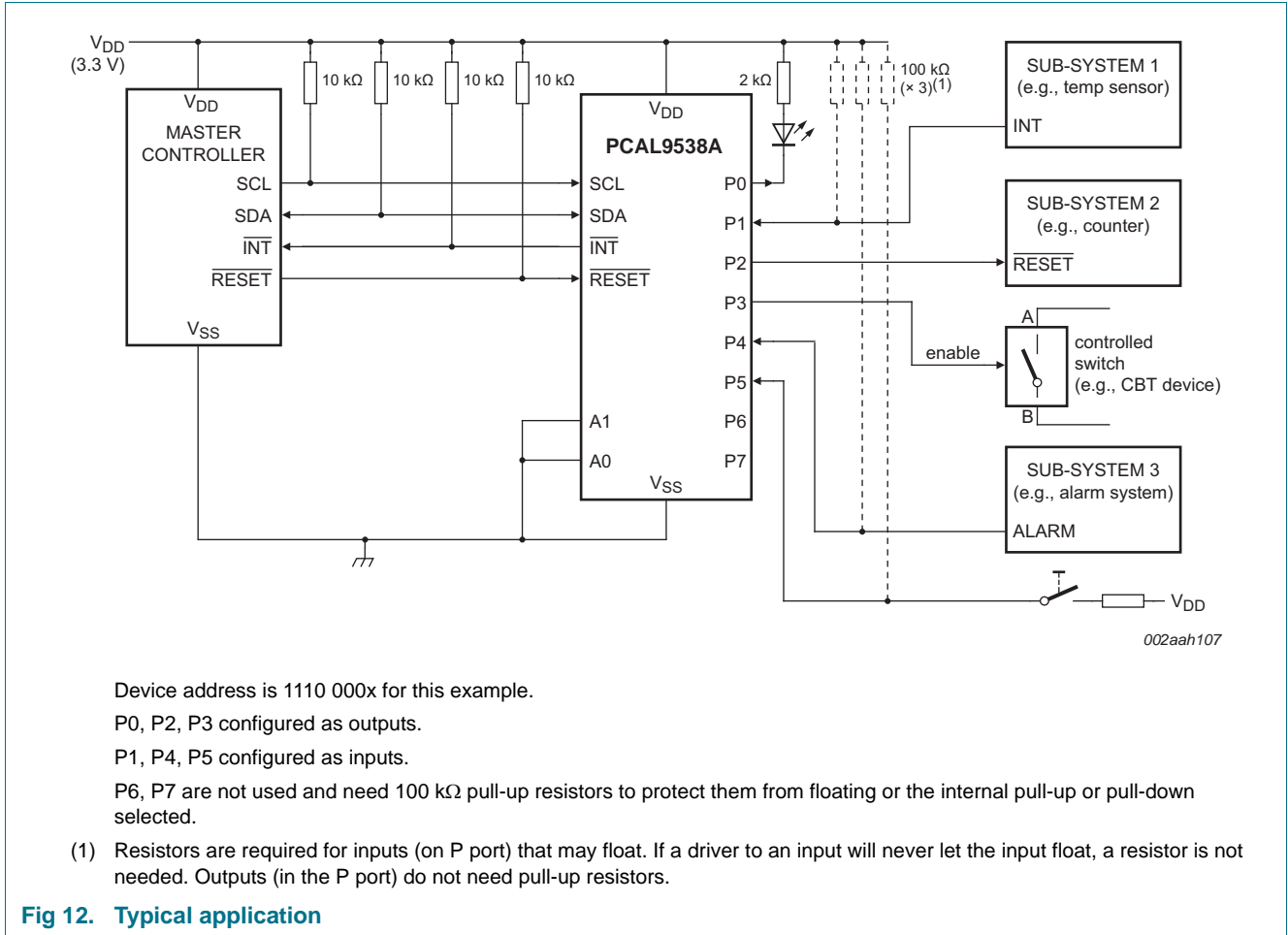

### 8.1 Minimizing I<sub>DD</sub> when the I/Os are used to control LEDs

When the I/Os are used to control LEDs, they are normally connected to V<sub>DD</sub> through a resistor as shown in Figure 12. Since the LED acts as a diode, when the LED is off the I/O V<sub>I</sub> is about 1.2 V less than V<sub>DD</sub>. The supply current, I<sub>DD</sub>, increases as V<sub>I</sub> becomes lower than V<sub>DD</sub>.

Designs needing to minimize current consumption, such as battery power applications, should consider maintaining the I/O pins greater than or equal to V<sub>DD</sub> when the LED is off. Figure 13 shows a high value resistor in parallel with the LED. Figure 14 shows V<sub>DD</sub> less than the LED supply voltage by at least 1.2 V. Both of these methods maintain the I/O V<sub>I</sub> at or above V<sub>DD</sub> and prevents additional supply current consumption when the LED is off.

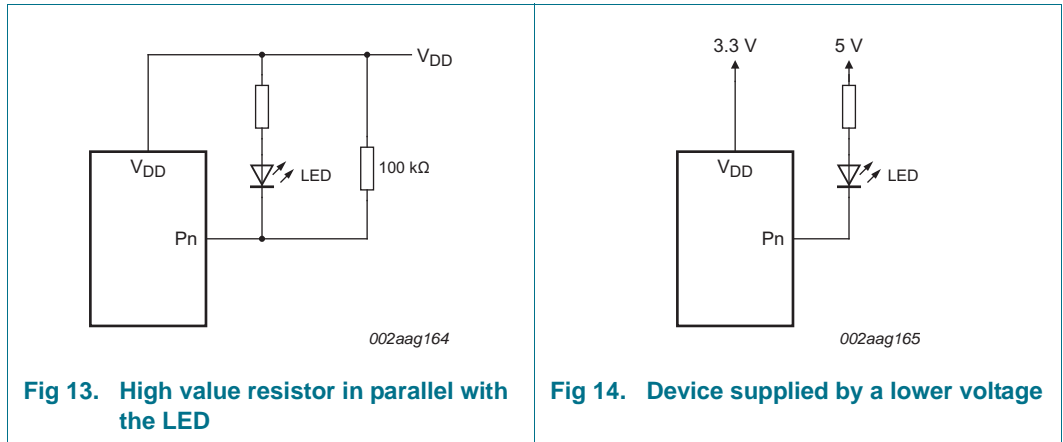

Fig 13. High value resistor in parallel with the LED

Fig 14. Device supplied by a lower voltage

### 8.2 Output drive strength control

The Output drive strength registers allow the user to control the output drive level of the GPIO. Each GPIO can be configured independently to one of the four possible output current levels. By programming these bits the user is changing the number of transistor pairs or ‘fingers’ that drive the I/O pad.

Figure 15 shows a simplified output stage. The behavior of the pad is affected by the Configuration register, the output port data, and the current control register. When the Current Control register bits are programmed to 10b, then only two of the fingers are active, reducing the current drive capability by 50 %.

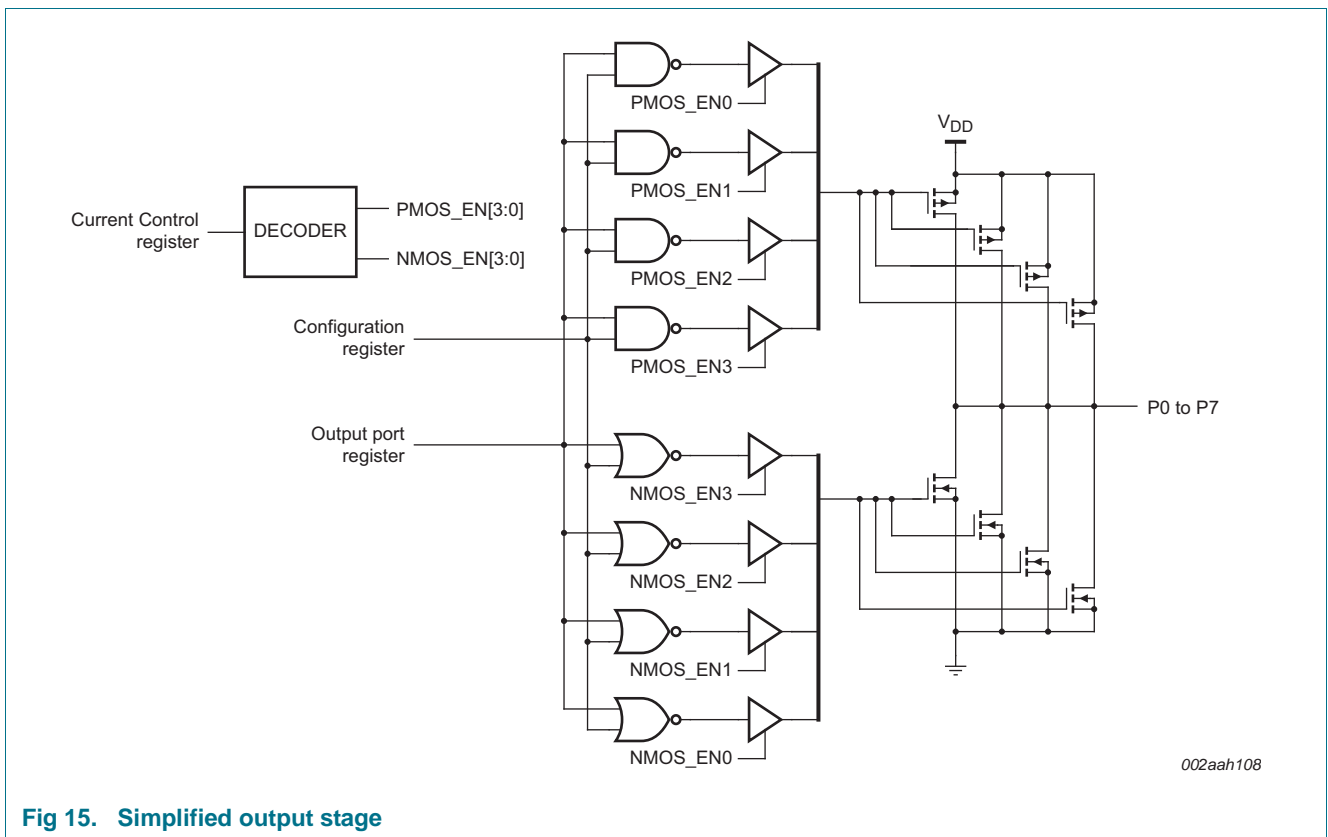

Fig 15. Simplified output stage

Reducing the current drive capability may be desirable to reduce system noise. When the output switches (transitions from H/L), there is a peak current that is a function of the output drive selection. This peak current runs through  $V_{DD}$  and  $V_{SS}$  package inductance and will create noise (some radiated, but more critically Simultaneous Switching Noise (SSN)). In other words, switching many outputs at the same time will create ground and supply noise. The output drive strength control through the Current Control registers allows the user to mitigate SSN issues without the need of additional external components.

### 8.3 12 V tolerant I/Os

The PCAL9538A device SCR group reference diode can go up to 10 V before latch back to 8 V. The ESD gate oxide will protect the device, but not if used continually. Therefore, to achieve 12 V tolerant I/Os, the external protection circuitry (diode) must be used as shown in [Figure 16](#).

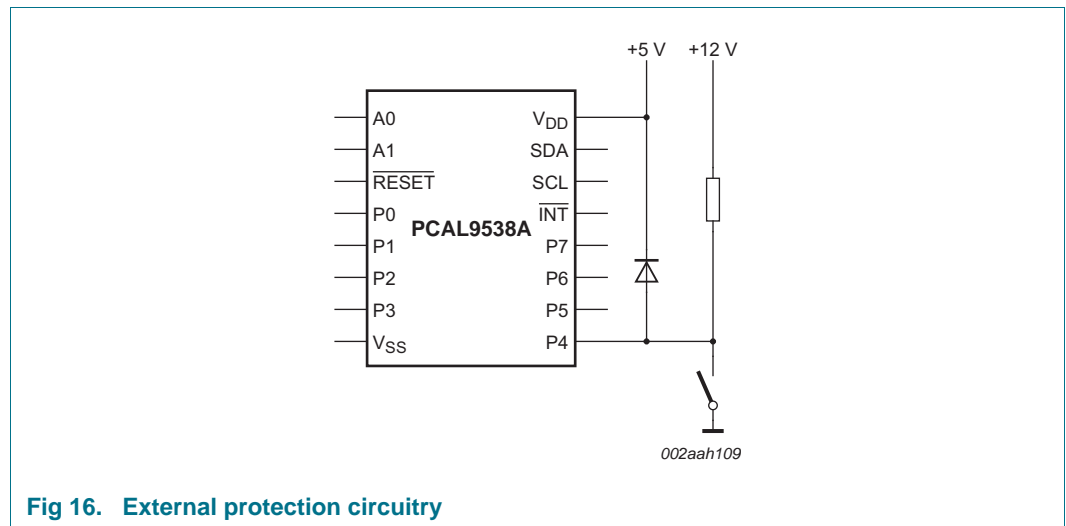

Fig 16. External protection circuitry

### 8.4 Power-on reset requirements

In the event of a glitch or data corruption, PCAL9538A can be reset to its default conditions by using the power-on reset feature. Power-on reset requires that the device go through a power cycle to be completely reset. This reset also happens when the device is powered on for the first time in an application.

The two types of power-on reset are shown in [Figure 17](#) and [Figure 18](#).

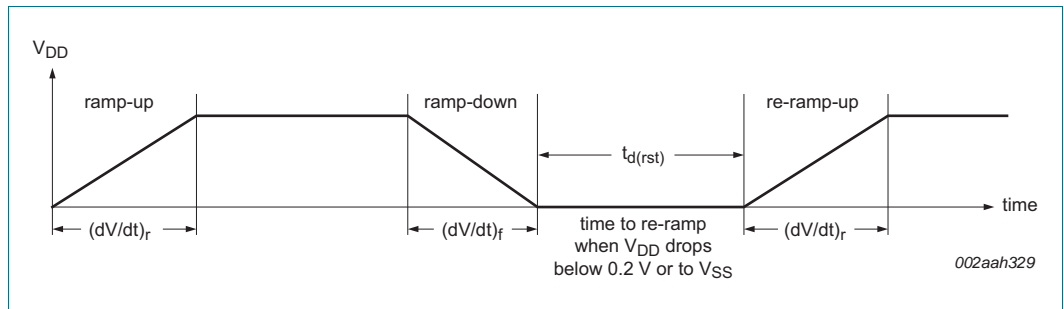

Fig 17. V<sub>DD</sub> is lowered below 0.2 V or 0 V and then ramped up to V<sub>DD</sub>

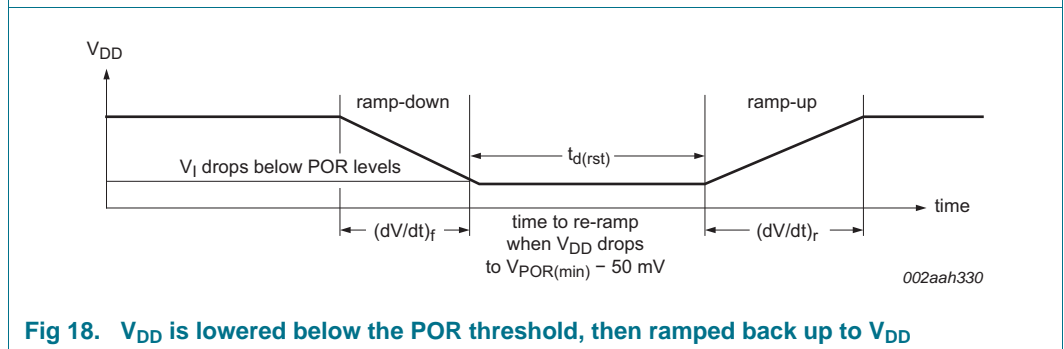

Fig 18. V<sub>DD</sub> is lowered below the POR threshold, then ramped back up to V<sub>DD</sub>

[Table 18](#) specifies the performance of the power-on reset feature for PCAL9538A for both types of power-on reset.

**Table 18. Recommended supply sequencing and ramp rates**  
*T<sub>amb</sub> = 25 °C (unless otherwise noted). Not tested; specified by design.*

Symbol	Parameter	Condition	Min	Typ	Max	Unit
(dV/dt) <sub>f</sub>	fall rate of change of voltage	<a href="#">Figure 17</a>	0.1	-	2000	ms
(dV/dt) <sub>r</sub>	rise rate of change of voltage	<a href="#">Figure 17</a>	0.1	-	2000	ms
t <sub>d(rst)</sub>	reset delay time	<a href="#">Figure 17</a> ; re-ramp time when V <sub>DD</sub> drops to V <sub>SS</sub>	1	-	-	μs
		<a href="#">Figure 18</a> ; re-ramp time when V <sub>DD</sub> drops to V <sub>POR(min)</sub> - 50 mV	1	-	-	μs
ΔV <sub>DD(gl)</sub>	glitch supply voltage difference	<a href="#">Figure 19</a>	[1]	-	1.0	V
t <sub>w(gl)VDD</sub>	supply voltage glitch pulse width	<a href="#">Figure 19</a>	[2]	-	10	μs
V <sub>POR(trip)</sub>	power-on reset trip voltage	falling V <sub>DD</sub>	0.7	-	-	V
		rising V <sub>DD</sub>	-	-	1.4	V

[1] Level that V<sub>DD</sub> can glitch down to, but not cause a functional disruption when t<sub>w(gl)VDD</sub> < 1 μs.

[2] Glitch width that will not cause a functional disruption when ΔV<sub>DD(gl)</sub> = 0.5 × V<sub>DD</sub>.

Glitches in the power supply can also affect the power-on reset performance of this device. The glitch width ( $t_{w(g)VD D}$ ) and glitch height ( $\Delta V_{DD(gl)}$ ) are dependent on each other. The bypass capacitance, source impedance, and device impedance are factors that affect power-on reset performance. [Figure 19](#) and [Table 18](#) provide more information on how to measure these specifications.

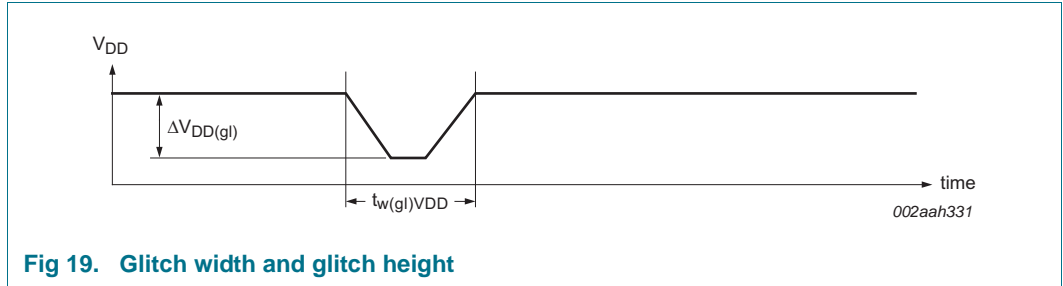

**Fig 19. Glitch width and glitch height**

$V_{POR}$  is critical to the power-on reset.  $V_{POR}$  is the voltage level at which the reset condition is released and all the registers and the I<sup>2</sup>C-bus/SMBus state machine are initialized to their default states. The value of  $V_{POR}$  differs based on the  $V_{DD}$  being lowered to or from 0 V. [Figure 20](#) and [Table 18](#) provide more details on this specification.

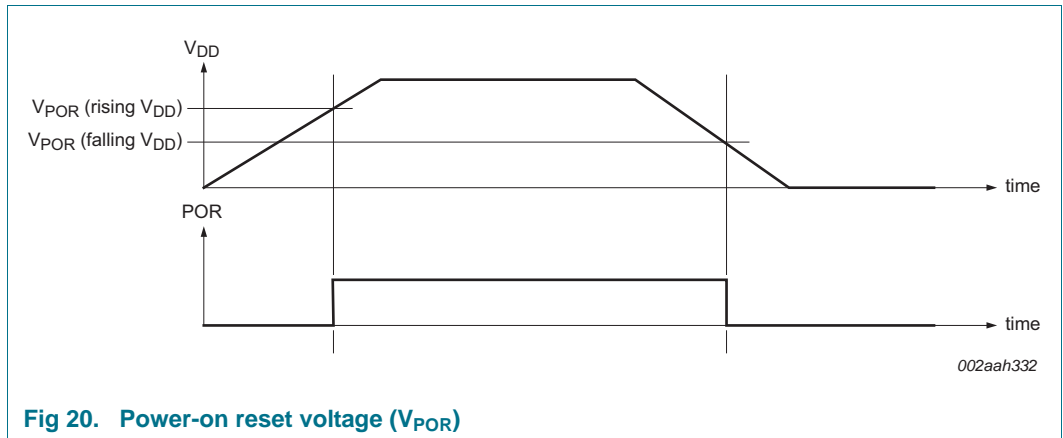

**Fig 20. Power-on reset voltage ( $V_{POR}$ )**

## 8.5 Device current consumption with internal pull-up and pull-down resistors

The PCAL9538A integrates programmable pull-up and pull-down resistors to eliminate external components when pins are configured as inputs and pull-up or pull-down resistors are required (for example, nothing is driving the inputs to the power supply rails). Since these pull-up and pull-down resistors are internal to the device itself, they contribute to the current consumption of the device and must be considered in the overall system design.

The pull-up or pull-down function is selected in register 44h, while the resistor is connected by the enable register 43h. The configuration of the resistors is shown in [Figure 6](#).

If the resistor is configured as a pull-up, that is, connected to  $V_{DD}$ , a current will flow from the  $V_{DD}$  pin through the resistor to ground when the pin is held LOW. This current will appear as additional  $I_{DD}$  upsetting any current consumption measurements.

In the same manner, if the resistor is configured as a pull-down and the pin is held HIGH, current will flow from the power supply through the pin to the  $V_{SS}$  pin. While this current will not be measured as part of  $I_{DD}$ , one must be mindful of the 200 mA limiting value through  $V_{SS}$ .

The pull-up and pull-down resistors are simple resistors and the current is linear with voltage. The resistance specification for these devices spans from 50 k $\Omega$  with a nominal 100 k $\Omega$  value. Any current flow through these resistors is additive by the number of pins held HIGH or LOW and the current can be calculated by Ohm's law. See [Figure 24](#) for a graph of supply current versus the number of pull-up resistors.

## 9. Limiting values

**Table 19. Limiting values**

In accordance with the Absolute Maximum Rating System (IEC 60134).

Symbol	Parameter	Conditions	Min	Max	Unit
V <sub>DD</sub>	supply voltage		-0.5	+6.5	V
V <sub>I</sub>	input voltage		[1] -0.5	+6.5	V
V <sub>O</sub>	output voltage		[1] -0.5	+6.5	V
I <sub>IK</sub>	input clamping current	A0, A1, $\overline{\text{RESET}}$ , SCL; V <sub>I</sub> < 0 V	-	±20	mA
I <sub>OK</sub>	output clamping current	$\overline{\text{INT}}$ ; V <sub>O</sub> < 0 V	-	±20	mA
I <sub>IOK</sub>	input/output clamping current	P port; V <sub>O</sub> < 0 V or V <sub>O</sub> > V <sub>DD</sub>	-	±20	mA
		SDA; V <sub>O</sub> < 0 V or V <sub>O</sub> > V <sub>DD</sub>	-	±20	mA
I <sub>OL</sub>	LOW-level output current	continuous; I/O port	-	50	mA
		continuous; SDA, $\overline{\text{INT}}$	-	25	mA
I <sub>OH</sub>	HIGH-level output current	continuous; P port	-	25	mA
I <sub>DD</sub>	supply current		-	160	mA
I <sub>SS</sub>	ground supply current		-	200	mA
P <sub>tot</sub>	total power dissipation		-	200	mW
T <sub>stg</sub>	storage temperature		-65	+150	°C
T <sub>j(max)</sub>	maximum junction temperature		-	125	°C

[1] The input negative-voltage and output voltage ratings may be exceeded if the input and output current ratings are observed.

## 10. Recommended operating conditions

**Table 20. Operating conditions**

Symbol	Parameter	Conditions	Min	Max	Unit
V <sub>DD</sub>	supply voltage		1.65	5.5	V
V <sub>IH</sub>	HIGH-level input voltage	SCL, SDA, $\overline{\text{RESET}}$	0.7 × V <sub>DD</sub>	5.5	V
		A0, A1, P port	0.7 × V <sub>DD</sub>	5.5	V
V <sub>IL</sub>	LOW-level input voltage	SCL, SDA, $\overline{\text{RESET}}$	-0.5	0.3 × V <sub>DD</sub>	V
		A0, A1, P port	-0.5	0.3 × V <sub>DD</sub>	V
I <sub>OH</sub>	HIGH-level output current	P port	-	10	mA
I <sub>OL</sub>	LOW-level output current	P port	-	25	mA
T <sub>amb</sub>	ambient temperature	operating in free air	-40	+85	°C

## 11. Thermal characteristics

**Table 21. Thermal characteristics**

Symbol	Parameter	Conditions	Max	Unit
Z <sub>th(j-a)</sub>	transient thermal impedance from junction to ambient	HVQFN16 package	[1] 53	K/W
		TSSOP16 package	[1] 108	K/W

[1] The package thermal impedance is calculated in accordance with JESD 51-7.

## 12. Static characteristics

**Table 22. Static characteristics**
 $T_{amb} = -40\text{ }^{\circ}\text{C to }+85\text{ }^{\circ}\text{C}; V_{DD} = 1.65\text{ V to }5.5\text{ V}; \text{ unless otherwise specified.}$ 

Symbol	Parameter	Conditions	Min	Typ <sup>[1]</sup>	Max	Unit	
V <sub>IK</sub>	input clamping voltage	I <sub>I</sub> = -18 mA	-1.2	-	-	V	
V <sub>POR</sub>	power-on reset voltage	V <sub>I</sub> = V <sub>DD</sub> or V <sub>SS</sub> ; I <sub>O</sub> = 0 mA	-	1.1	1.4	V	
V <sub>OH</sub>	HIGH-level output voltage <sup>[2]</sup>	P port; I <sub>OH</sub> = -8 mA; CCX = 11b					
		V <sub>DD</sub> = 1.65 V	1.2	-	-	V	
		V <sub>DD</sub> = 2.3 V	1.8	-	-	V	
		V <sub>DD</sub> = 3 V	2.6	-	-	V	
		V <sub>DD</sub> = 4.5 V	4.1	-	-	V	
		P port; I <sub>OH</sub> = -2.5 mA and CCX = 00b; I <sub>OH</sub> = -5 mA and CCX = 01b; I <sub>OH</sub> = -7.5 mA and CCX = 10b; I <sub>OH</sub> = -10 mA and CCX = 11b					
		V <sub>DD</sub> = 1.65 V	1.1	-	-	V	
		V <sub>DD</sub> = 2.3 V	1.7	-	-	V	
		V <sub>DD</sub> = 3 V	2.5	-	-	V	
V <sub>OL</sub>	LOW-level output voltage <sup>[2]</sup>	P port; I <sub>OL</sub> = 8 mA; CCX = 11b					
		V <sub>DD</sub> = 1.65 V	-	-	0.45	V	
		V <sub>DD</sub> = 2.3 V	-	-	0.25	V	
		V <sub>DD</sub> = 3 V	-	-	0.25	V	
		V <sub>DD</sub> = 4.5 V	-	-	0.2	V	
		P port; I <sub>OL</sub> = 2.5 mA and CCX = 00b; I <sub>OL</sub> = 5 mA and CCX = 01b; I <sub>OL</sub> = 7.5 mA and CCX = 10b; I <sub>OL</sub> = 10 mA and CCX = 11b					
		V <sub>DD</sub> = 1.65 V	-	-	0.5	V	
		V <sub>DD</sub> = 2.3 V	-	-	0.3	V	
		V <sub>DD</sub> = 3 V	-	-	0.25	V	
I <sub>OL</sub>	LOW-level output current	V <sub>OL</sub> = 0.4 V; V <sub>DD</sub> = 1.65 V to 5.5 V					
		SDA	3	-	-	mA	
		$\overline{\text{INT}}$	3	15 <sup>[3]</sup>	-	mA	
I <sub>I</sub>	input current	V <sub>DD</sub> = 1.65 V to 5.5 V					
		SCL, SDA, $\overline{\text{RESET}}$ ; V <sub>I</sub> = V <sub>DD</sub> or V <sub>SS</sub>	-	-	0.1	μA	
		A0, A1; V <sub>I</sub> = V <sub>DD</sub> or V <sub>SS</sub>	-	-	±1	μA	
I <sub>IH</sub>	HIGH-level input current	P port; V <sub>I</sub> = V <sub>DD</sub> ; V <sub>DD</sub> = 1.65 V to 5.5 V	-	-	1	μA	
I <sub>IL</sub>	LOW-level input current	P port; V <sub>I</sub> = V <sub>SS</sub> ; V <sub>DD</sub> = 1.65 V to 5.5 V	-	-	1	μA	

**Table 22. Static characteristics ...continued**

$T_{amb} = -40\text{ }^{\circ}\text{C}$  to  $+85\text{ }^{\circ}\text{C}$ ;  $V_{DD} = 1.65\text{ V}$  to  $5.5\text{ V}$ ; unless otherwise specified.

Symbol	Parameter	Conditions	Min	Typ <sup>[1]</sup>	Max	Unit	
I <sub>DD</sub>	supply current	SDA, P port, A0, A1, $\overline{\text{RESET}}$ ; $V_I$ on SDA and $\overline{\text{RESET}} = V_{DD}$ or $V_{SS}$ ; $V_I$ on P port and A0, A1 = $V_{DD}$ ; $I_O = 0\text{ mA}$ ; I/O = inputs; $f_{SCL} = 400\text{ kHz}$					
		$V_{DD} = 3.6\text{ V}$ to $5.5\text{ V}$	-	10	25	$\mu\text{A}$	
		$V_{DD} = 2.3\text{ V}$ to $3.6\text{ V}$	-	6.5	15	$\mu\text{A}$	
		$V_{DD} = 1.65\text{ V}$ to $2.3\text{ V}$	-	4	9	$\mu\text{A}$	
		SCL, SDA, P port, A0, A1, $\overline{\text{RESET}}$ ; $V_I$ on SCL, SDA and $\overline{\text{RESET}} = V_{DD}$ or $V_{SS}$ ; $V_I$ on P port and A0, A1 = $V_{DD}$ ; $I_O = 0\text{ mA}$ ; I/O = inputs; $f_{SCL} = 0\text{ kHz}$					
		$V_{DD} = 3.6\text{ V}$ to $5.5\text{ V}$	-	1.5	7	$\mu\text{A}$	
		$V_{DD} = 2.3\text{ V}$ to $3.6\text{ V}$	-	1	3.2	$\mu\text{A}$	
$\Delta I_{DD}$	additional quiescent supply current	SCL, SDA, $\overline{\text{RESET}}$ ; one input at $V_{DD} - 0.6\text{ V}$ , other inputs at $V_{DD}$ or $V_{SS}$ ; $V_{DD} = 1.65\text{ V}$ to $5.5\text{ V}$	-	-	25	$\mu\text{A}$	
		P port, A0, A1; one input at $V_{DD} - 0.6\text{ V}$ , other inputs at $V_{DD}$ or $V_{SS}$ ; $V_{DD} = 1.65\text{ V}$ to $5.5\text{ V}$	-	-	80	$\mu\text{A}$	
C <sub>i</sub>	input capacitance	$V_I = V_{DD}$ or $V_{SS}$ ; $V_{DD} = 1.65\text{ V}$ to $5.5\text{ V}$	-	6	7	pF	
C <sub>io</sub>	input/output capacitance	$V_{I/O} = V_{DD}$ or $V_{SS}$ ; $V_{DD} = 1.65\text{ V}$ to $5.5\text{ V}$	-	7	8	pF	
		$V_{I/O} = V_{DD}$ or $V_{SS}$ ; $V_{DD} = 1.65\text{ V}$ to $5.5\text{ V}$	-	7.5	8.5	pF	
R <sub>pu(int)</sub>	internal pull-up resistance	input/output	50	100	150	k $\Omega$	
R <sub>pd(int)</sub>	internal pull-down resistance	input/output	50	100	150	k $\Omega$	

[1] For I<sub>DD</sub>, all typical values are at nominal supply voltage (1.8 V, 2.5 V, 3.3 V, 3.6 V or 5 V V<sub>DD</sub>) and T<sub>amb</sub> = 25 °C. Except for I<sub>DD</sub>, the typical values are at V<sub>DD</sub> = 3.3 V and T<sub>amb</sub> = 25 °C.

[2] The total current sourced by all I/Os must be limited to 160 mA, and total current sunk by all I/Os must be limited to 200 mA.

[3] Typical value for T<sub>amb</sub> = 25 °C. V<sub>OL</sub> = 0.4 V and V<sub>DD</sub> = 3.3 V. Typical value for V<sub>DD</sub> < 2.5 V, V<sub>OL</sub> = 0.6 V.

12.1 Typical characteristics

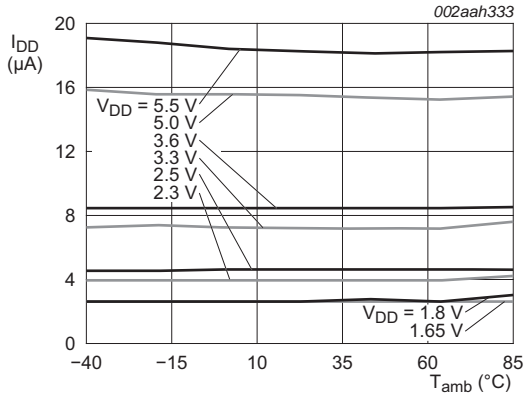

Fig 21. Supply current versus ambient temperature

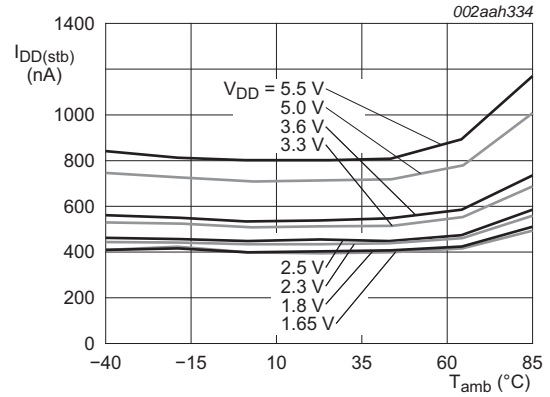

Fig 22. Standby supply current versus ambient temperature

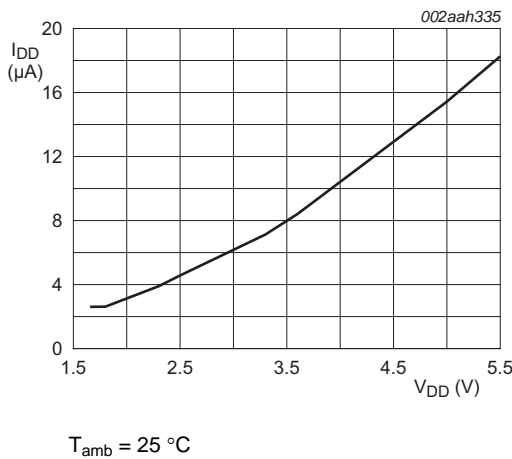

Fig 23. Supply current versus supply voltage

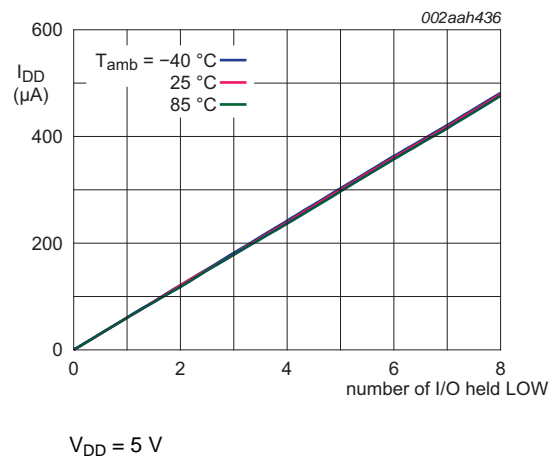
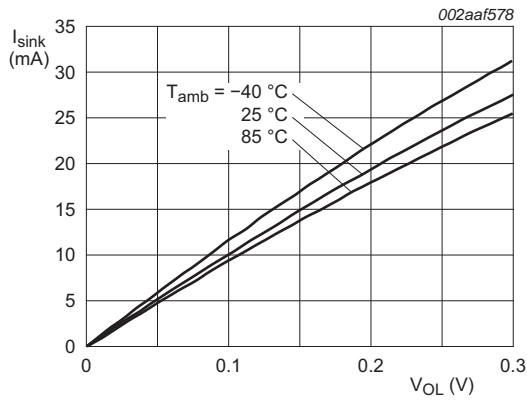
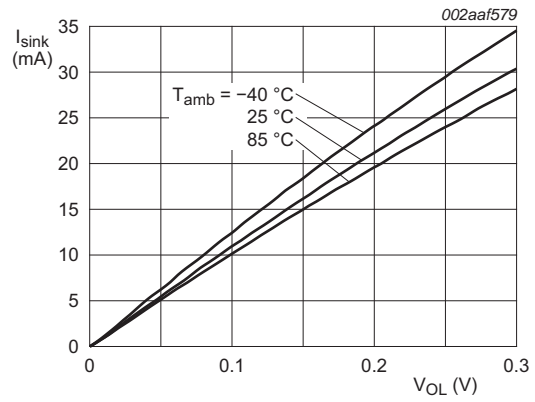

Fig 24. Supply current versus number of I/O held LOW



a.  $V_{DD} = 1.65 \text{ V}$



b.  $V_{DD} = 1.8 \text{ V}$

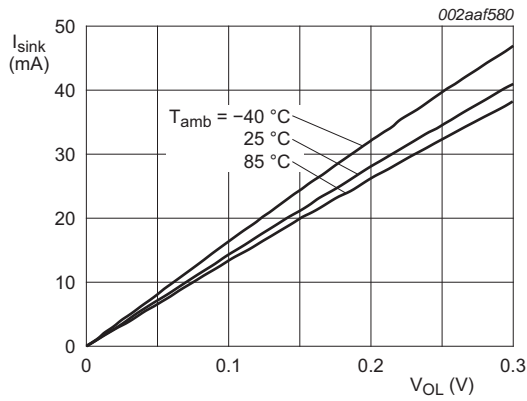

c.  $V_{DD} = 2.5 \text{ V}$

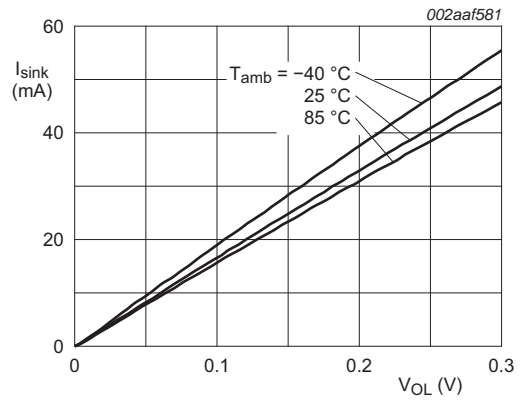

d.  $V_{DD} = 3.3 \text{ V}$

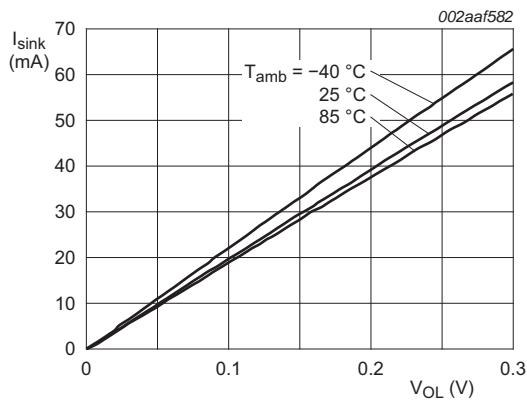

e.  $V_{DD} = 5.0 \text{ V}$

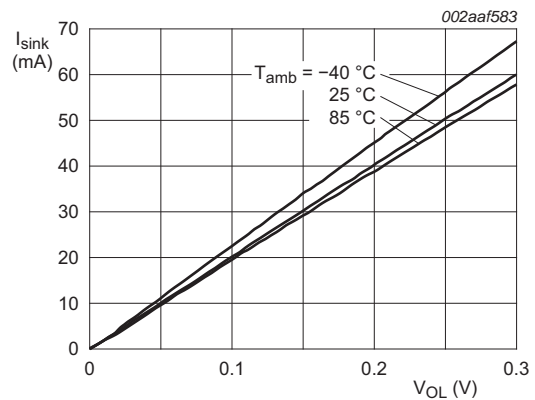

f.  $V_{DD} = 5.5 \text{ V}$

**Fig 25. I/O sink current versus LOW-level output voltage with CCX.X = 11b**

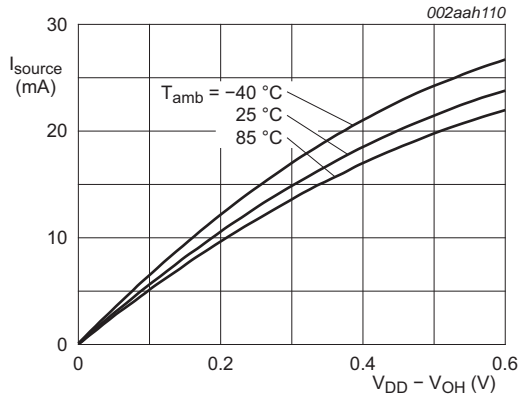

a.  $V_{DD} = 1.65\text{ V}$

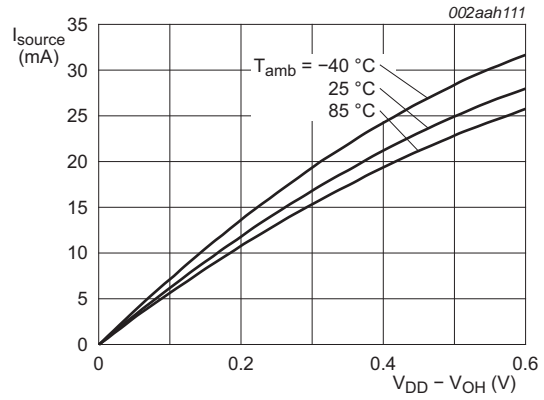

b.  $V_{DD} = 1.8\text{ V}$

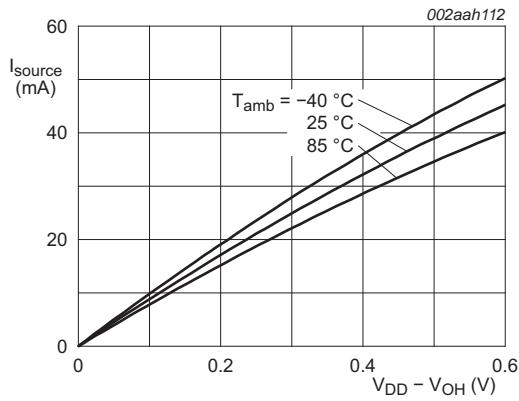

c.  $V_{DD} = 2.5\text{ V}$

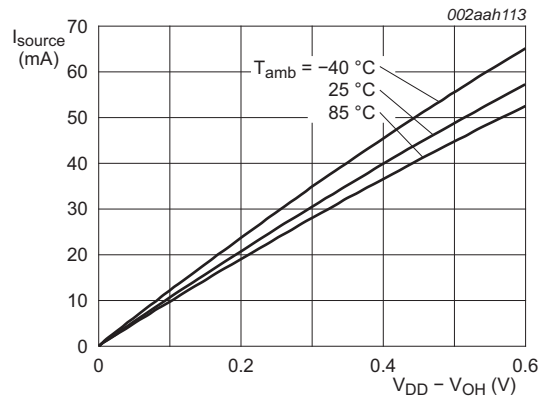

d.  $V_{DD} = 3.3\text{ V}$

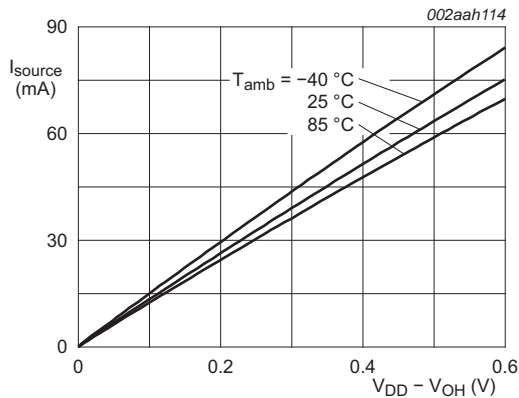

e.  $V_{DD} = 5.0\text{ V}$

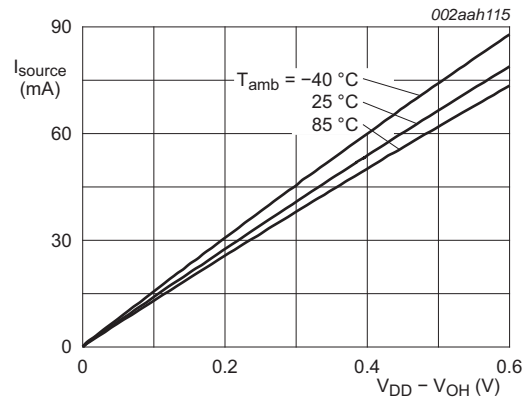

f.  $V_{DD} = 5.5\text{ V}$

**Fig 26. I/O source current versus HIGH-level output voltage with CCX.X = 11b**

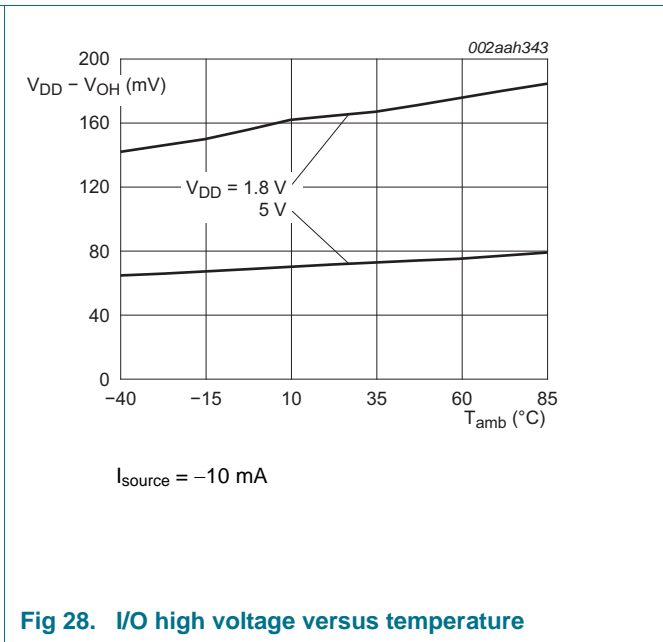
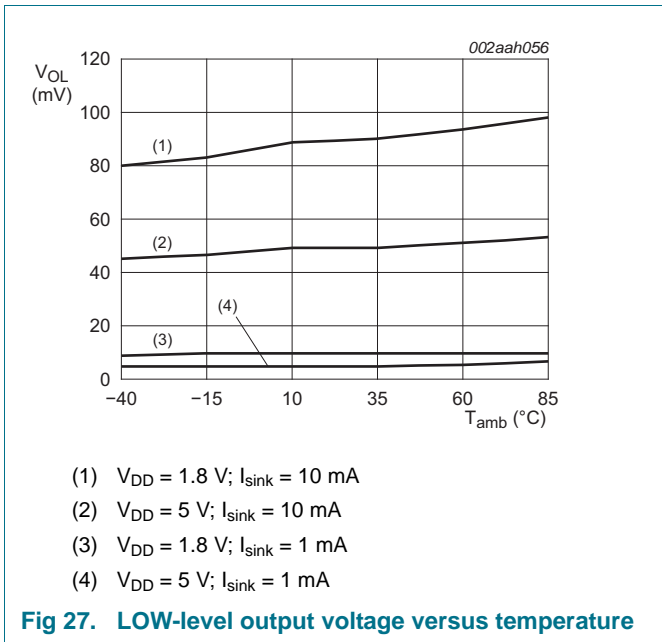

### 13. Dynamic characteristics

**Table 23. I<sup>2</sup>C-bus interface timing requirements**

Over recommended operating free air temperature range, unless otherwise specified. See [Figure 29](#).

Symbol	Parameter	Conditions	Standard-mode I <sup>2</sup> C-bus		Fast-mode I <sup>2</sup> C-bus		Unit
			Min	Max	Min	Max	
f <sub>SCL</sub>	SCL clock frequency		0	100	0	400	kHz
t <sub>HIGH</sub>	HIGH period of the SCL clock		4	-	0.6	-	μs
t <sub>LOW</sub>	LOW period of the SCL clock		4.7	-	1.3	-	μs
t <sub>SP</sub>	pulse width of spikes that must be suppressed by the input filter		0	50	0	50	ns
t <sub>SU;DAT</sub>	data set-up time		250	-	100	-	ns
t <sub>HD;DAT</sub>	data hold time		0	-	0	-	ns
t <sub>r</sub>	rise time of both SDA and SCL signals		-	1000	20	300	ns
t <sub>f</sub>	fall time of both SDA and SCL signals		-	300	20 × (V <sub>DD</sub> / 5.5 V)	300	ns
t <sub>BUF</sub>	bus free time between a STOP and START condition		4.7	-	1.3	-	μs
t <sub>SU;STA</sub>	set-up time for a repeated START condition		4.7	-	0.6	-	μs
t <sub>HD;STA</sub>	hold time (repeated) START condition		4	-	0.6	-	μs
t <sub>SU;STO</sub>	set-up time for STOP condition		4	-	0.6	-	μs
t <sub>VD;DAT</sub>	data valid time	SCL LOW to SDA output valid	-	3.45	-	0.9	μs
t <sub>VD;ACK</sub>	data valid acknowledge time	ACK signal from SCL LOW to SDA (out) LOW	-	3.45	-	0.9	μs

**Table 24. Reset timing requirements**

Over recommended operating free air temperature range, unless otherwise specified. See [Figure 32](#).

Symbol	Parameter	Conditions	Standard-mode I <sup>2</sup> C-bus		Fast-mode I <sup>2</sup> C-bus		Unit
			Min	Max	Min	Max	
t <sub>w(rst)</sub>	reset pulse width		30	-	30	-	ns
t <sub>rec(rst)</sub>	reset recovery time		200	-	200	-	ns
t <sub>rst</sub>	reset time		[1]	600	-	600	ns

[1] Minimum time for SDA to become HIGH or minimum time to wait before doing a START.

**Table 25. Switching characteristics**

Over recommended operating free air temperature range;  $C_L \leq 100$  pF; unless otherwise specified. See [Figure 29](#).

Symbol	Parameter	Conditions	Standard-mode I <sup>2</sup> C-bus		Fast-mode I <sup>2</sup> C-bus		Unit
			Min	Max	Min	Max	
$t_{V(INT)}$	valid time on pin $\overline{INT}$	from P port to $\overline{INT}$	-	1	-	1	$\mu$ s
$t_{rst(INT)}$	reset time on pin $\overline{INT}$	from SCL to $\overline{INT}$	-	1	-	1	$\mu$ s
$t_{V(Q)}$	data output valid time	from SCL to P port	-	400	-	400	ns
$t_{su(D)}$	data input set-up time	from P port to SCL	0	-	0	-	ns
$t_{h(D)}$	data input hold time	from P port to SCL	300	-	300	-	ns

## 14. Parameter measurement information

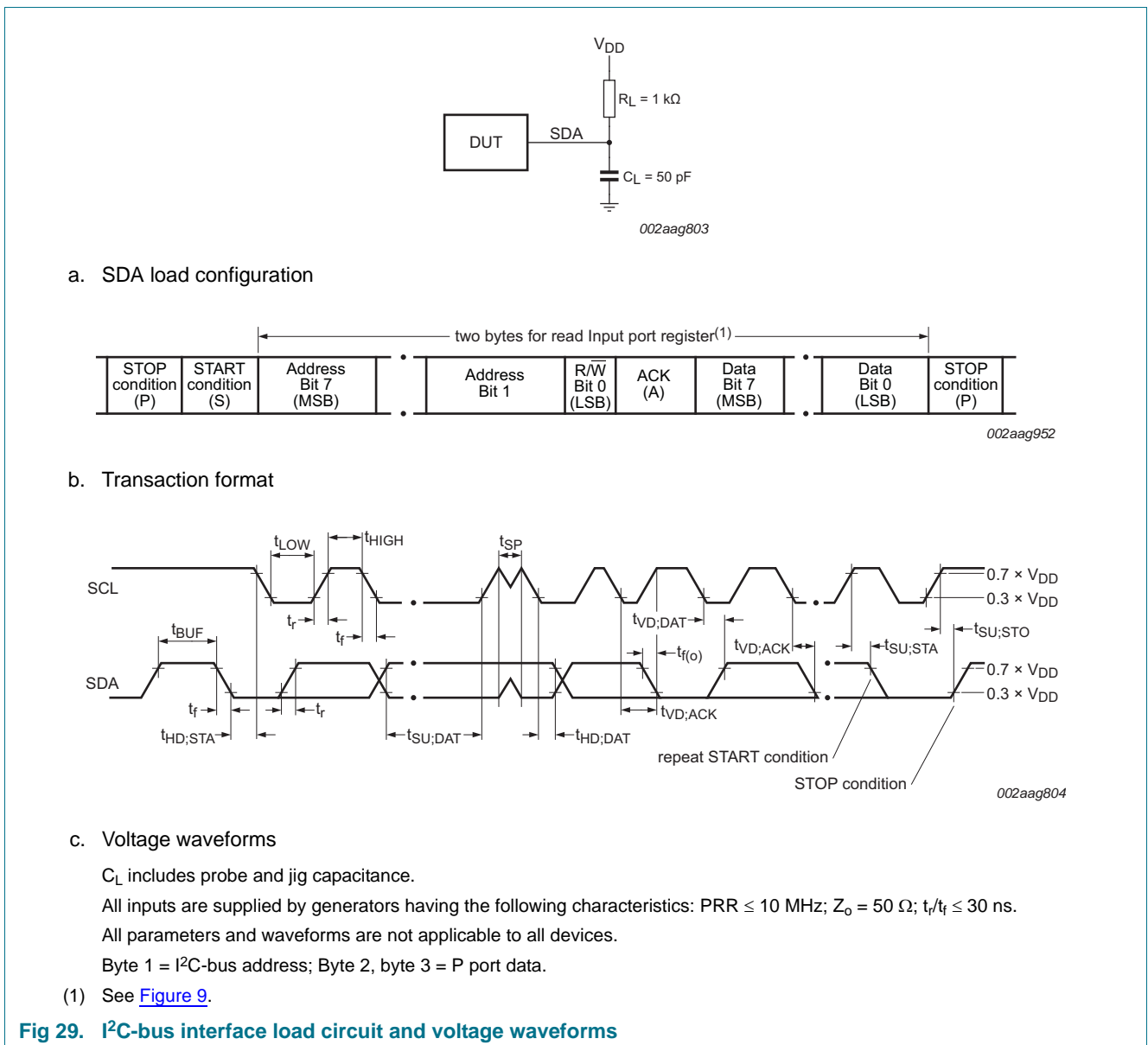

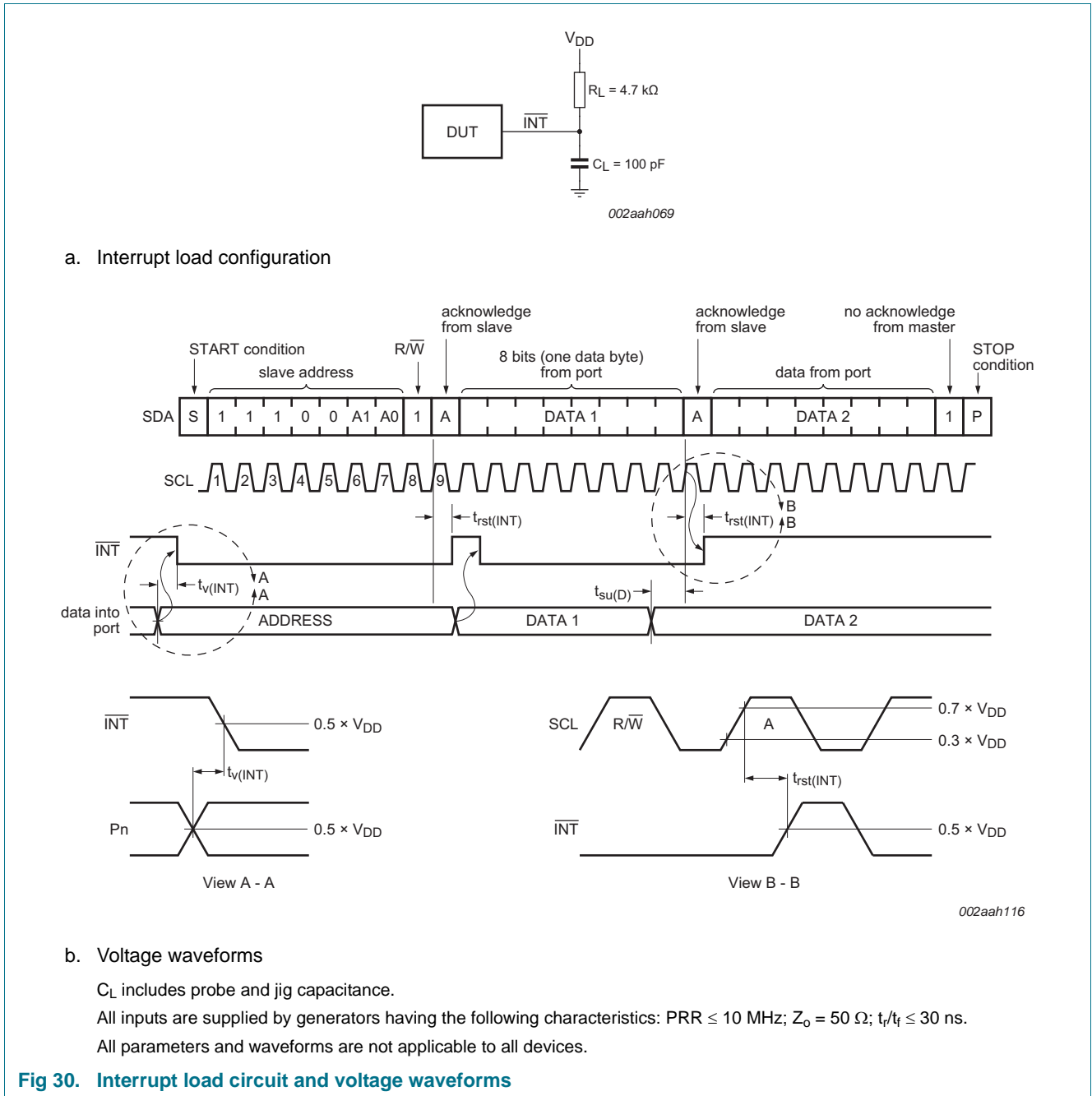

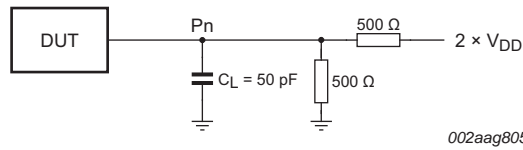

a. P port load configuration

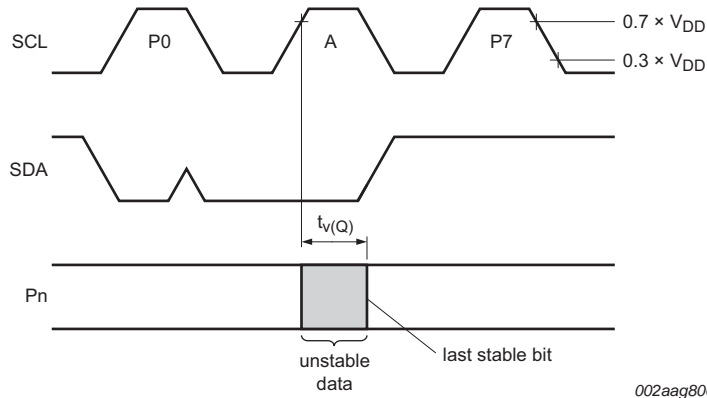

b. Write mode ( $\overline{R/\overline{W}} = 0$ )

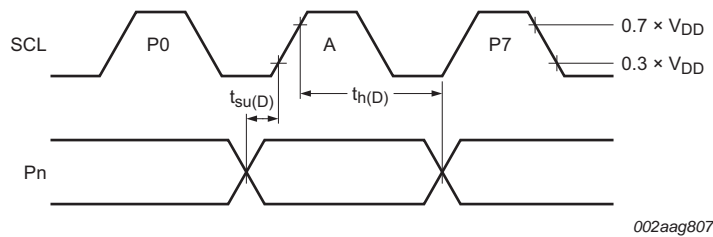

c. Read mode ( $\overline{R/\overline{W}} = 1$ )

$C_L$  includes probe and jig capacitance.

$t_{V(Q)}$  is measured from  $0.7 \times V_{DD}$  on SCL to 50 % I/O ( $P_n$ ) output.

All inputs are supplied by generators having the following characteristics: PRR  $\leq$  10 MHz;  $Z_o = 50 \Omega$ ;  $t_r/t_f \leq 30$  ns.

The outputs are measured one at a time, with one transition per measurement.

All parameters and waveforms are not applicable to all devices.

Fig 31. P port load circuit and voltage waveforms

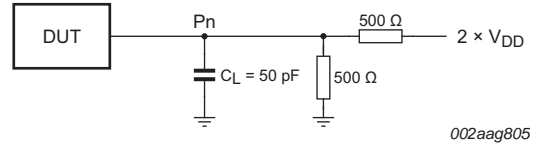
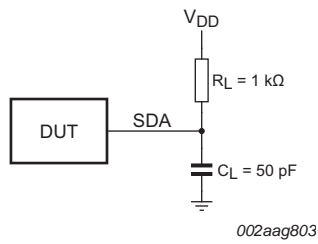

a. SDA load configuration

b. P port load configuration

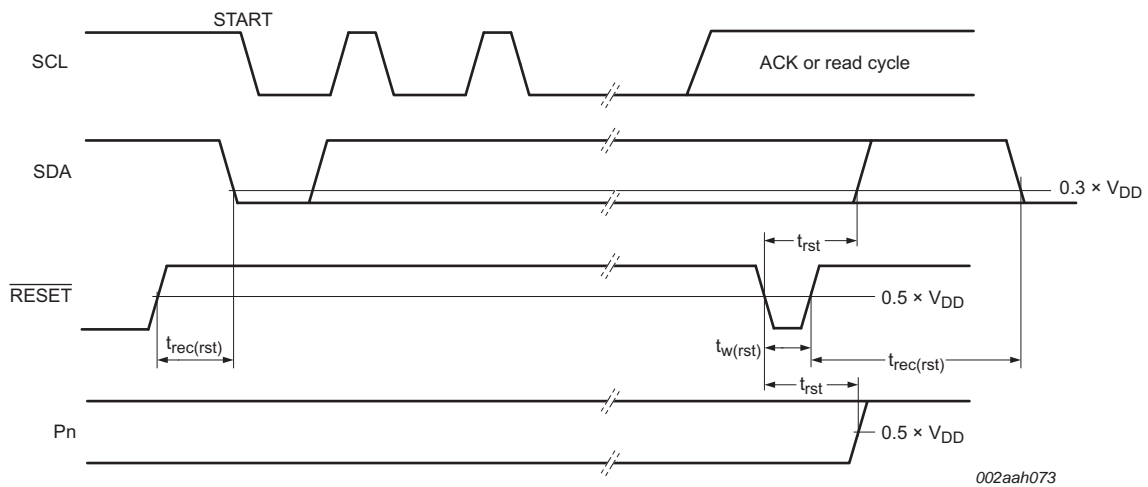

c. RESET timing

$C_L$  includes probe and jig capacitance.

All inputs are supplied by generators having the following characteristics:  $PRR \leq 10$  MHz;  $Z_o = 50 \Omega$ ;  $t_r/t_f \leq 30$  ns.

The outputs are measured one at a time, with one transition per measurement.

I/Os are configured as inputs.

All parameters and waveforms are not applicable to all devices.

**Fig 32. Reset load circuits and voltage waveforms**

15. Package outline

HVQFN16: plastic thermal enhanced very thin quad flat package; no leads;  
16 terminals; body 3 x 3 x 0.85 mm

SOT758-1

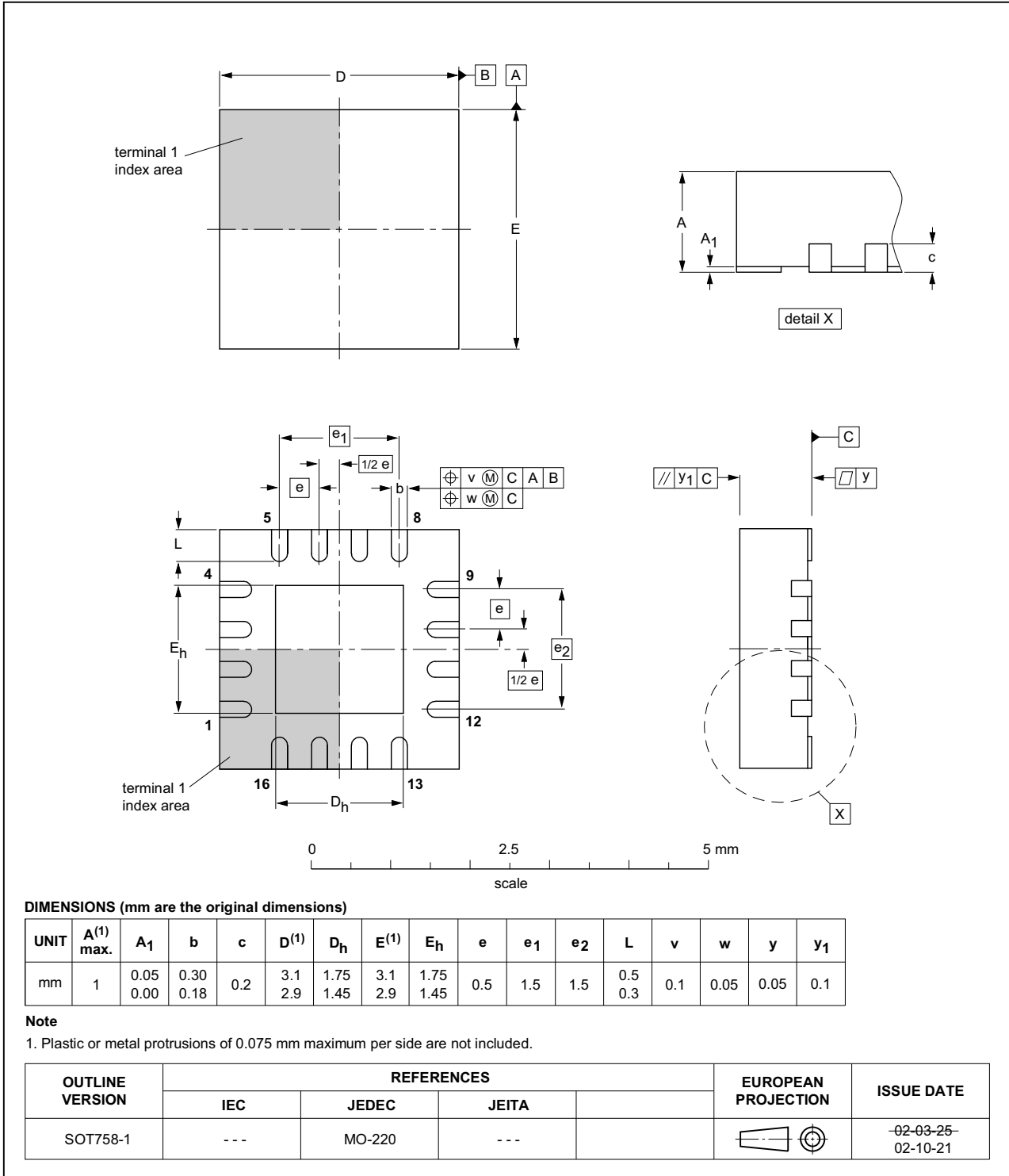

Fig 33. Package outline SOT758-1 (HVQFN16)

TSSOP16: plastic thin shrink small outline package; 16 leads; body width 4.4 mm

SOT403-1

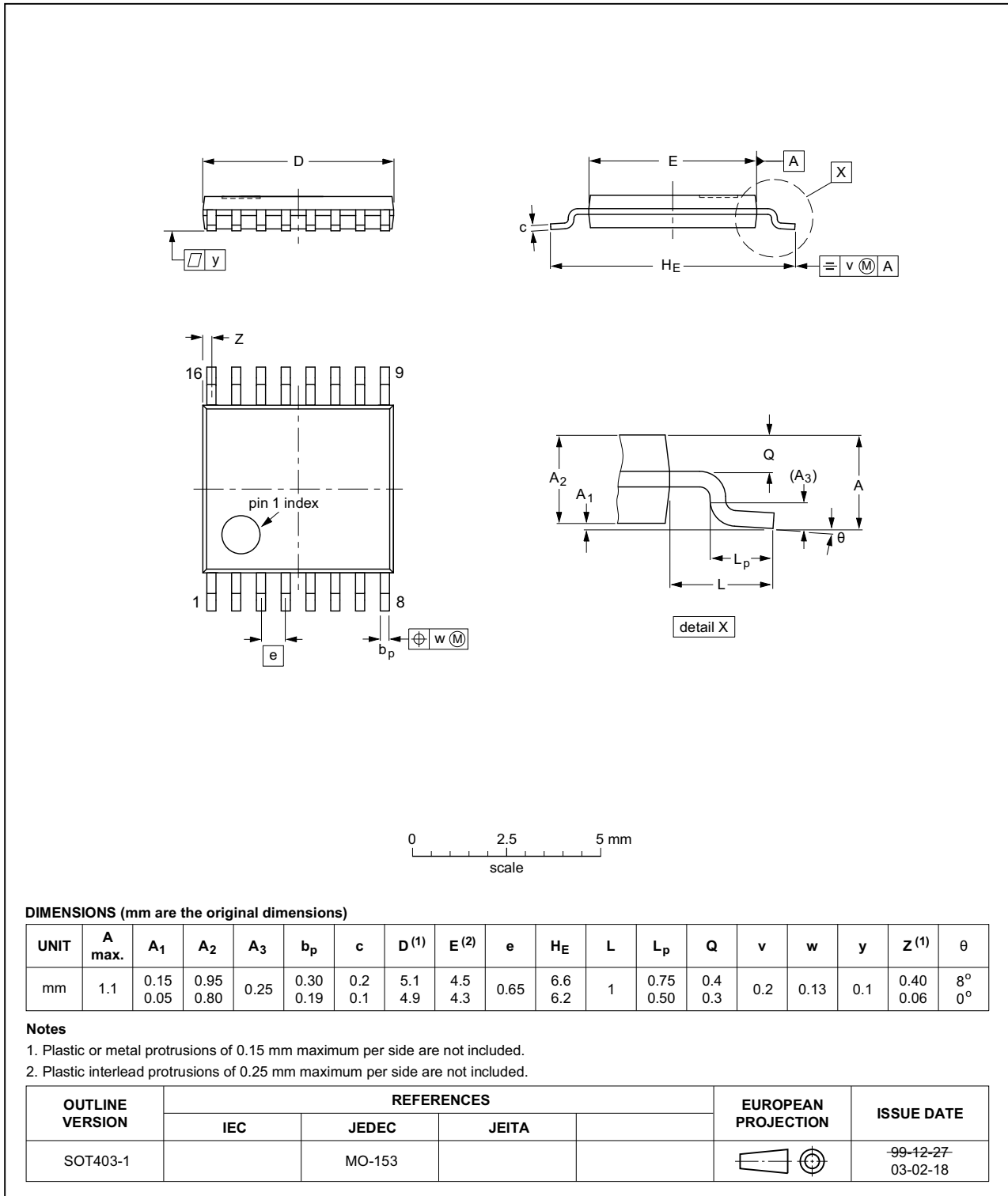

Fig 34. Package outline SOT403-1 (TSSOP16)

## 16. Handling information

All input and output pins are protected against ElectroStatic Discharge (ESD) under normal handling. When handling ensure that the appropriate precautions are taken as described in *JESD625-A* or equivalent standards.

## 17. Soldering of SMD packages

This text provides a very brief insight into a complex technology. A more in-depth account of soldering ICs can be found in Application Note *AN10365 "Surface mount reflow soldering description"*.

### 17.1 Introduction to soldering

Soldering is one of the most common methods through which packages are attached to Printed Circuit Boards (PCBs), to form electrical circuits. The soldered joint provides both the mechanical and the electrical connection. There is no single soldering method that is ideal for all IC packages. Wave soldering is often preferred when through-hole and Surface Mount Devices (SMDs) are mixed on one printed wiring board; however, it is not suitable for fine pitch SMDs. Reflow soldering is ideal for the small pitches and high densities that come with increased miniaturization.

### 17.2 Wave and reflow soldering

Wave soldering is a joining technology in which the joints are made by solder coming from a standing wave of liquid solder. The wave soldering process is suitable for the following:

- Through-hole components
- Leaded or leadless SMDs, which are glued to the surface of the printed circuit board

Not all SMDs can be wave soldered. Packages with solder balls, and some leadless packages which have solder lands underneath the body, cannot be wave soldered. Also, leaded SMDs with leads having a pitch smaller than ~0.6 mm cannot be wave soldered, due to an increased probability of bridging.

The reflow soldering process involves applying solder paste to a board, followed by component placement and exposure to a temperature profile. Leaded packages, packages with solder balls, and leadless packages are all reflow solderable.

Key characteristics in both wave and reflow soldering are:

- Board specifications, including the board finish, solder masks and vias
- Package footprints, including solder thieves and orientation
- The moisture sensitivity level of the packages
- Package placement
- Inspection and repair
- Lead-free soldering versus SnPb soldering

### 17.3 Wave soldering

Key characteristics in wave soldering are:

- Process issues, such as application of adhesive and flux, clinching of leads, board transport, the solder wave parameters, and the time during which components are exposed to the wave
- Solder bath specifications, including temperature and impurities

## 17.4 Reflow soldering

Key characteristics in reflow soldering are:

- Lead-free versus SnPb soldering; note that a lead-free reflow process usually leads to higher minimum peak temperatures (see [Figure 35](#)) than a SnPb process, thus reducing the process window
- Solder paste printing issues including smearing, release, and adjusting the process window for a mix of large and small components on one board
- Reflow temperature profile; this profile includes preheat, reflow (in which the board is heated to the peak temperature) and cooling down. It is imperative that the peak temperature is high enough for the solder to make reliable solder joints (a solder paste characteristic). In addition, the peak temperature must be low enough that the packages and/or boards are not damaged. The peak temperature of the package depends on package thickness and volume and is classified in accordance with [Table 26](#) and [27](#)

**Table 26. SnPb eutectic process (from J-STD-020D)**

Package thickness (mm)	Package reflow temperature (°C)	
	Volume (mm <sup>3</sup> )	
	< 350	≥ 350
< 2.5	235	220
≥ 2.5	220	220

**Table 27. Lead-free process (from J-STD-020D)**

Package thickness (mm)	Package reflow temperature (°C)		
	Volume (mm <sup>3</sup> )		
	< 350	350 to 2000	> 2000
< 1.6	260	260	260
1.6 to 2.5	260	250	245
> 2.5	250	245	245

Moisture sensitivity precautions, as indicated on the packing, must be respected at all times.

Studies have shown that small packages reach higher temperatures during reflow soldering, see [Figure 35](#).

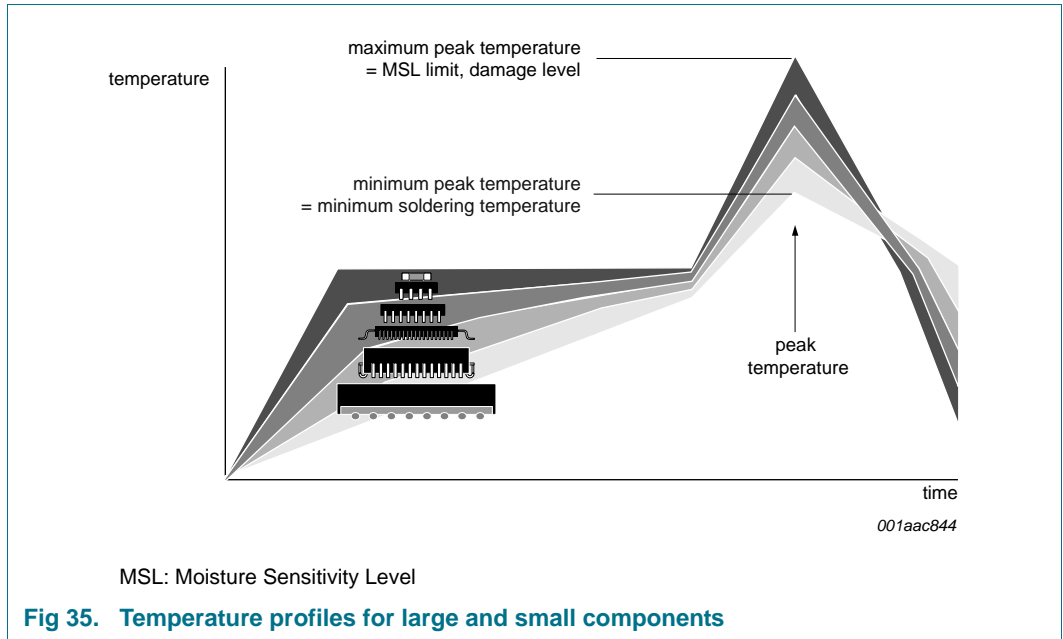

For further information on temperature profiles, refer to Application Note AN10365 “Surface mount reflow soldering description”.

18. Soldering: PCB footprints

Footprint information for reflow soldering of HVQFN16 package

SOT758-1

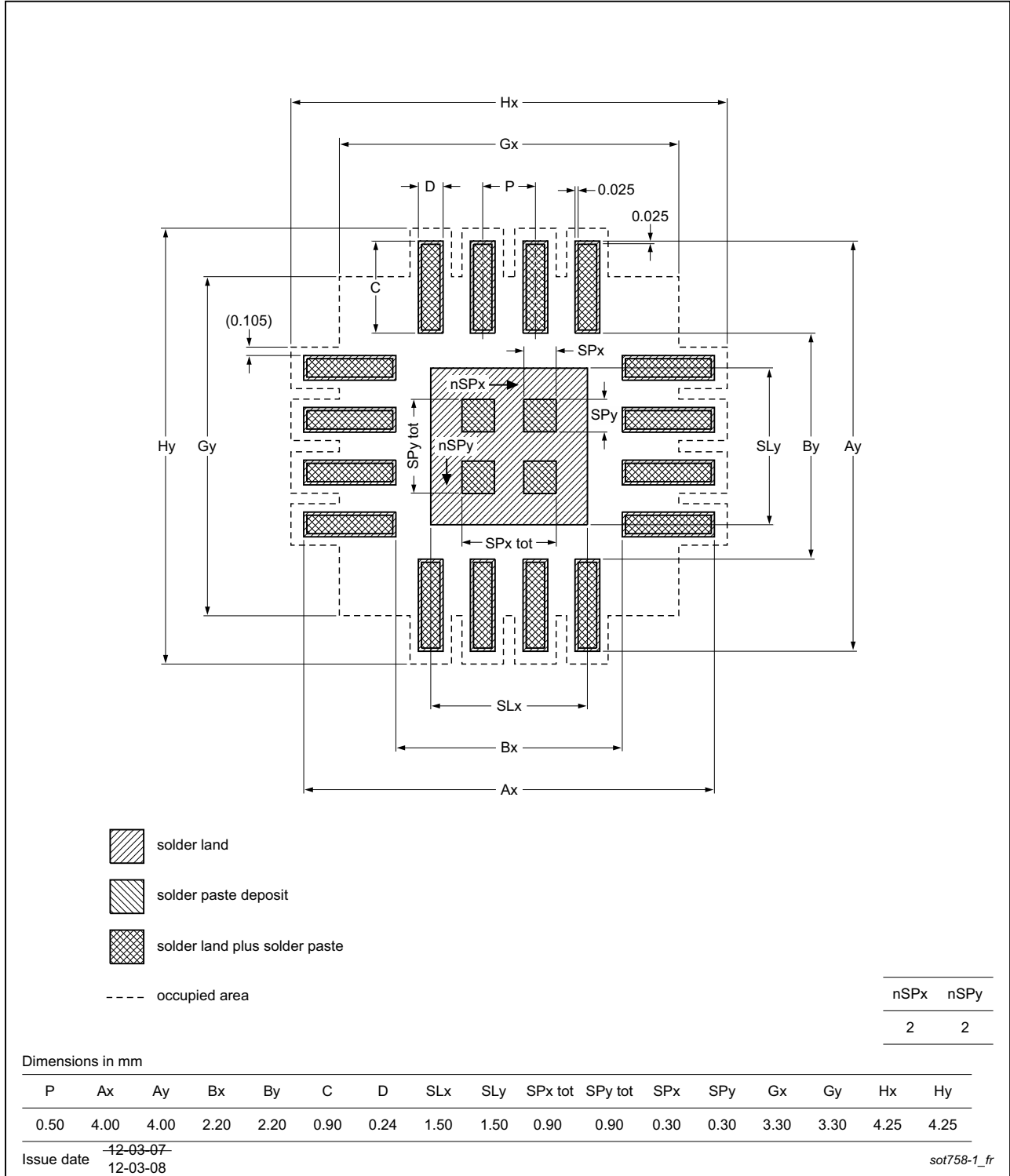

Fig 36. PCB footprint for SOT758-1 (HVQFN16); reflow soldering

Footprint information for reflow soldering of TSSOP16 package

SOT403-1

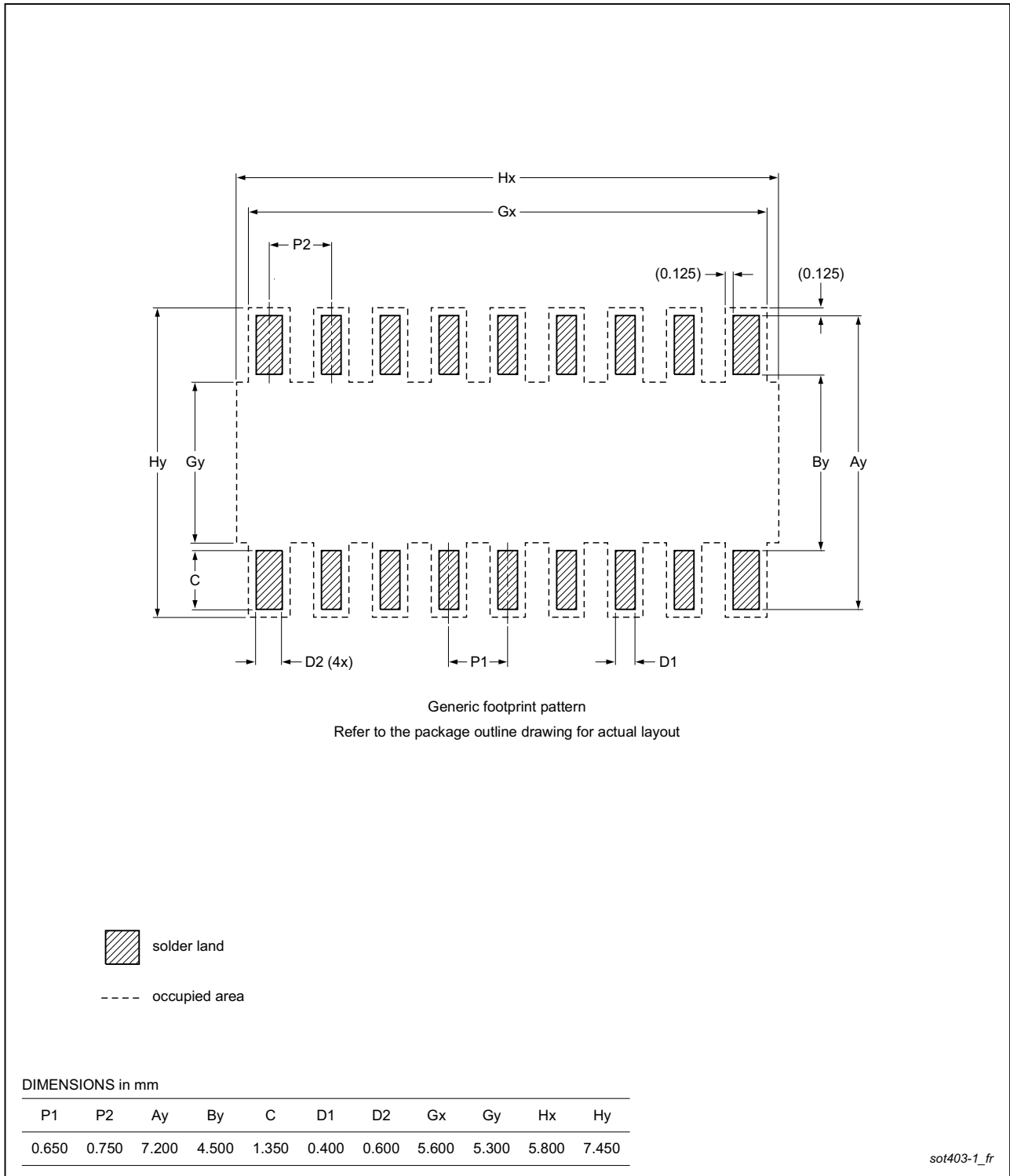

Fig 37. PCB footprint for SOT403-1 (TSSOP16); reflow soldering

## 19. Abbreviations

Table 28. Abbreviations

Acronym	Description
ACPI	Advanced Configuration and Power Interface
CBT	Cross-Bar Technology
CDM	Charged-Device Model
CMOS	Complementary Metal-Oxide Semiconductor
ESD	ElectroStatic Discharge
FET	Field-Effect Transistor
FF	Flip-Flop
GPIO	General Purpose Input/Output
HBM	Human Body Model
I <sup>2</sup> C-bus	Inter-Integrated Circuit bus
I/O	Input/Output
LED	Light Emitting Diode
LP	Low-Pass
LSB	Least Significant Bit
MSB	Most Significant Bit
POR	Power-On Reset
PRR	Pulse Repetition Rate
SCR	Silicon Controlled Rectifier
SMBus	System Management Bus

## 20. Revision history

Table 29. Revision history

Document ID	Release date	Data sheet status	Change notice	Supersedes
PCAL9538A v.3.1	20150527	Product data sheet	-	PCAL9538A v.3
Modifications:	<ul style="list-style-type: none"> <li><a href="#">Section 2.1</a>: Part type corrected from "PCA9539 and PCA9539A" to "PCA9538 and PCA9538A"</li> </ul>			
PCAL9538A v.3	20130809	Product data sheet	-	PCAL9538A v.2
PCAL9538A v.2	20121210	Product data sheet	-	PCAL9538A v.1
PCAL9538A v.1	20120928	Product data sheet	-	-

## 21. Legal information

### 21.1 Data sheet status

Document status <sup>[1][2]</sup>	Product status <sup>[3]</sup>	Definition
Objective [short] data sheet	Development	This document contains data from the objective specification for product development.
Preliminary [short] data sheet	Qualification	This document contains data from the preliminary specification.
Product [short] data sheet	Production	This document contains the product specification.

[1] Please consult the most recently issued document before initiating or completing a design.

[2] The term 'short data sheet' is explained in section "Definitions".

[3] The product status of device(s) described in this document may have changed since this document was published and may differ in case of multiple devices. The latest product status information is available on the Internet at URL <http://www.nxp.com>.

### 21.2 Definitions

**Draft** — The document is a draft version only. The content is still under internal review and subject to formal approval, which may result in modifications or additions. NXP Semiconductors does not give any representations or warranties as to the accuracy or completeness of information included herein and shall have no liability for the consequences of use of such information.

**Short data sheet** — A short data sheet is an extract from a full data sheet with the same product type number(s) and title. A short data sheet is intended for quick reference only and should not be relied upon to contain detailed and full information. For detailed and full information see the relevant full data sheet, which is available on request via the local NXP Semiconductors sales office. In case of any inconsistency or conflict with the short data sheet, the full data sheet shall prevail.

**Product specification** — The information and data provided in a Product data sheet shall define the specification of the product as agreed between NXP Semiconductors and its customer, unless NXP Semiconductors and customer have explicitly agreed otherwise in writing. In no event however, shall an agreement be valid in which the NXP Semiconductors product is deemed to offer functions and qualities beyond those described in the Product data sheet.

### 21.3 Disclaimers

**Limited warranty and liability** — Information in this document is believed to be accurate and reliable. However, NXP Semiconductors does not give any representations or warranties, expressed or implied, as to the accuracy or completeness of such information and shall have no liability for the consequences of use of such information. NXP Semiconductors takes no responsibility for the content in this document if provided by an information source outside of NXP Semiconductors.

In no event shall NXP Semiconductors be liable for any indirect, incidental, punitive, special or consequential damages (including - without limitation - lost profits, lost savings, business interruption, costs related to the removal or replacement of any products or rework charges) whether or not such damages are based on tort (including negligence), warranty, breach of contract or any other legal theory.

Notwithstanding any damages that customer might incur for any reason whatsoever, NXP Semiconductors' aggregate and cumulative liability towards customer for the products described herein shall be limited in accordance with the *Terms and conditions of commercial sale* of NXP Semiconductors.

**Right to make changes** — NXP Semiconductors reserves the right to make changes to information published in this document, including without limitation specifications and product descriptions, at any time and without notice. This document supersedes and replaces all information supplied prior to the publication hereof.

**Suitability for use** — NXP Semiconductors products are not designed, authorized or warranted to be suitable for use in life support, life-critical or safety-critical systems or equipment, nor in applications where failure or malfunction of an NXP Semiconductors product can reasonably be expected to result in personal injury, death or severe property or environmental damage. NXP Semiconductors and its suppliers accept no liability for inclusion and/or use of NXP Semiconductors products in such equipment or applications and therefore such inclusion and/or use is at the customer's own risk.

**Applications** — Applications that are described herein for any of these products are for illustrative purposes only. NXP Semiconductors makes no representation or warranty that such applications will be suitable for the specified use without further testing or modification.

Customers are responsible for the design and operation of their applications and products using NXP Semiconductors products, and NXP Semiconductors accepts no liability for any assistance with applications or customer product design. It is customer's sole responsibility to determine whether the NXP Semiconductors product is suitable and fit for the customer's applications and products planned, as well as for the planned application and use of customer's third party customer(s). Customers should provide appropriate design and operating safeguards to minimize the risks associated with their applications and products.

NXP Semiconductors does not accept any liability related to any default, damage, costs or problem which is based on any weakness or default in the customer's applications or products, or the application or use by customer's third party customer(s). Customer is responsible for doing all necessary testing for the customer's applications and products using NXP Semiconductors products in order to avoid a default of the applications and the products or of the application or use by customer's third party customer(s). NXP does not accept any liability in this respect.

**Limiting values** — Stress above one or more limiting values (as defined in the Absolute Maximum Ratings System of IEC 60134) will cause permanent damage to the device. Limiting values are stress ratings only and (proper) operation of the device at these or any other conditions above those given in the Recommended operating conditions section (if present) or the Characteristics sections of this document is not warranted. Constant or repeated exposure to limiting values will permanently and irreversibly affect the quality and reliability of the device.

**Terms and conditions of commercial sale** — NXP Semiconductors products are sold subject to the general terms and conditions of commercial sale, as published at <http://www.nxp.com/profile/terms>, unless otherwise agreed in a valid written individual agreement. In case an individual agreement is concluded only the terms and conditions of the respective agreement shall apply. NXP Semiconductors hereby expressly objects to applying the customer's general terms and conditions with regard to the purchase of NXP Semiconductors products by customer.

**No offer to sell or license** — Nothing in this document may be interpreted or construed as an offer to sell products that is open for acceptance or the grant, conveyance or implication of any license under any copyrights, patents or other industrial or intellectual property rights.

**Export control** — This document as well as the item(s) described herein may be subject to export control regulations. Export might require a prior authorization from competent authorities.

**Quick reference data** — The Quick reference data is an extract of the product data given in the Limiting values and Characteristics sections of this document, and as such is not complete, exhaustive or legally binding.

**Non-automotive qualified products** — Unless this data sheet expressly states that this specific NXP Semiconductors product is automotive qualified, the product is not suitable for automotive use. It is neither qualified nor tested in accordance with automotive testing or application requirements. NXP Semiconductors accepts no liability for inclusion and/or use of non-automotive qualified products in automotive equipment or applications.

In the event that customer uses the product for design-in and use in automotive applications to automotive specifications and standards, customer (a) shall use the product without NXP Semiconductors' warranty of the product for such automotive applications, use and specifications, and (b)

whenever customer uses the product for automotive applications beyond NXP Semiconductors' specifications such use shall be solely at customer's own risk, and (c) customer fully indemnifies NXP Semiconductors for any liability, damages or failed product claims resulting from customer design and use of the product for automotive applications beyond NXP Semiconductors' standard warranty and NXP Semiconductors' product specifications.

**Translations** — A non-English (translated) version of a document is for reference only. The English version shall prevail in case of any discrepancy between the translated and English versions.

## 21.4 Trademarks

Notice: All referenced brands, product names, service names and trademarks are the property of their respective owners.

**I<sup>2</sup>C-bus** — logo is a trademark of NXP Semiconductors N.V.

## 22. Contact information

For more information, please visit: <http://www.nxp.com>

For sales office addresses, please send an email to: [salesaddresses@nxp.com](mailto:salesaddresses@nxp.com)

## 23. Contents

<b>1</b>	<b>General description</b> . . . . .	<b>1</b>	<b>13</b>	<b>Dynamic characteristics</b> . . . . .	<b>29</b>
<b>2</b>	<b>Features and benefits</b> . . . . .	<b>2</b>	<b>14</b>	<b>Parameter measurement information</b> . . . . .	<b>30</b>
2.1	Agile I/O features . . . . .	2	<b>15</b>	<b>Package outline</b> . . . . .	<b>34</b>
<b>3</b>	<b>Ordering information</b> . . . . .	<b>3</b>	<b>16</b>	<b>Handling information</b> . . . . .	<b>36</b>
3.1	Ordering options . . . . .	3	<b>17</b>	<b>Soldering of SMD packages</b> . . . . .	<b>36</b>
<b>4</b>	<b>Block diagram</b> . . . . .	<b>3</b>	17.1	Introduction to soldering . . . . .	36
<b>5</b>	<b>Pinning information</b> . . . . .	<b>4</b>	17.2	Wave and reflow soldering . . . . .	36
5.1	Pinning . . . . .	4	17.3	Wave soldering . . . . .	36
5.2	Pin description . . . . .	4	17.4	Reflow soldering . . . . .	37
<b>6</b>	<b>Functional description</b> . . . . .	<b>5</b>	<b>18</b>	<b>Soldering: PCB footprints</b> . . . . .	<b>39</b>
6.1	Device address . . . . .	5	<b>19</b>	<b>Abbreviations</b> . . . . .	<b>41</b>
6.2	Pointer register and command byte . . . . .	5	<b>20</b>	<b>Revision history</b> . . . . .	<b>41</b>
6.3	Interface definition . . . . .	6	<b>21</b>	<b>Legal information</b> . . . . .	<b>42</b>
6.4	Register descriptions . . . . .	6	21.1	Data sheet status . . . . .	42
6.4.1	Input port register (00h) . . . . .	6	21.2	Definitions . . . . .	42
6.4.2	Output port register (01h) . . . . .	6	21.3	Disclaimers . . . . .	42
6.4.3	Polarity inversion register (02h) . . . . .	7	21.4	Trademarks . . . . .	43
6.4.4	Configuration register (03h) . . . . .	7	<b>22</b>	<b>Contact information</b> . . . . .	<b>43</b>
6.4.5	Output drive strength registers (40h, 41h) . . . . .	7	<b>23</b>	<b>Contents</b> . . . . .	<b>44</b>
6.4.6	Input latch register (42h) . . . . .	8			
6.4.7	Pull-up/pull-down enable register (43h) . . . . .	8			
6.4.8	Pull-up/pull-down selection register (44h) . . . . .	9			
6.4.9	Interrupt mask register (45h) . . . . .	9			
6.4.10	Interrupt status register (46h) . . . . .	9			
6.4.11	Output port configuration register (4Fh) . . . . .	10			
6.5	I/O port . . . . .	11			
6.6	Power-on reset . . . . .	12			
6.7	Reset input ( <b>RESET</b> ) . . . . .	12			
6.8	Interrupt output ( <b>INT</b> ) . . . . .	12			
<b>7</b>	<b>Bus transactions</b> . . . . .	<b>13</b>			
7.1	Write commands . . . . .	13			
7.2	Read commands . . . . .	14			
<b>8</b>	<b>Application design-in information</b> . . . . .	<b>16</b>			
8.1	Minimizing I <sub>DD</sub> when the I/Os are used to control LEDs . . . . .	16			
8.2	Output drive strength control . . . . .	17			
8.3	12 V tolerant I/Os . . . . .	18			
8.4	Power-on reset requirements . . . . .	19			
8.5	Device current consumption with internal pull-up and pull-down resistors . . . . .	21			
<b>9</b>	<b>Limiting values</b> . . . . .	<b>22</b>			
<b>10</b>	<b>Recommended operating conditions</b> . . . . .	<b>22</b>			
<b>11</b>	<b>Thermal characteristics</b> . . . . .	<b>22</b>			
<b>12</b>	<b>Static characteristics</b> . . . . .	<b>23</b>			
12.1	Typical characteristics . . . . .	25			

Please be aware that important notices concerning this document and the product(s) described herein, have been included in section 'Legal information'.

© NXP Semiconductors N.V. 2015.

All rights reserved.

For more information, please visit: <http://www.nxp.com>

For sales office addresses, please send an email to: [salesaddresses@nxp.com](mailto:salesaddresses@nxp.com)

Date of release: 27 May 2015

Document identifier: PCAL9538A