

# TEA1623P; TEA1623PH

STARplug switched mode power supply controller IC

Rev. 3 — 30 August 2010

Product data sheet

## 1. General description

---

The TEA1623 is a Switched Mode Power Supply (SMPS) controller IC that operates directly from rectified universal mains. It is implemented in the high voltage EZ-HV SOI process, combined with a low voltage BiCMOS process.

The device includes a high voltage power switch and a circuit for start-up directly from the rectified mains voltage. A dedicated circuit for valley switching is built in, which makes a very efficient slim-line electronic power-plug concept possible.

In its most basic version of application, the TEA1623 acts as a voltage source. Here, no additional secondary electronics are required. A combined voltage and current source can be realized with minimum costs for external components. Implementation of the TEA1623 renders an efficient and low cost power supply system.

## 2. Features and benefits

---

- Designed for general purpose power supplies
- Integrated power switch: 6.5  $\Omega$  and 650 V
- Operates from universal AC mains supplies: 80 V to 276 V
- Adjustable frequency for flexible design
- RC oscillator for stable output regulation
- Valley switching for minimum switch-on loss
- Frequency reduction at low power output for low standby power: < 100 mW
- Adjustable OverCurrent Protection (OCP)
- UnderVoltage Protection (UVP)
- Temperature protection
- Short-winding protection
- Safe restart mode for system fault conditions
- Simple application with both primary and secondary (opto) feedback
- Available in 8-pin and 16-pin DIP packages.

## 3. Applications

---

- Adapters
- Set-Top Box (STB)
- DVD
- VCD
- CD(R)
- PC Silverbox standby SMPS



## 4. Quick reference data

Table 1. Quick reference data

Symbol	Parameter	Conditions	Min	Typ	Max	Unit
$V_{CC(max)}$	maximum supply voltage		-	-	40	V
$V_{DRAIN(max)}$	maximum DMOS power transistor drain voltage	$T_j > 0\text{ °C}$	-	-	650	V
$I_{DRAIN}$	supply current drawn from pin DRAIN	no auxiliary supply	-	0.5	-	mA
$R_{DSon}$	drain-source on-state resistance	$I_{SOURCE} = -0.5\text{ A}$				
		$T_j = 25\text{ °C}$	-	6.5	7.5	$\Omega$
		$T_j = 100\text{ °C}$	-	9.0	10.0	$\Omega$
$f_{osc}$	oscillator frequency range		10	-	200	kHz

## 5. Ordering information

Table 2. Ordering information

Type number	Package		
	Name	Description	Version
TEA1623P	DIP8	plastic dual in-line package; 8 leads (300 mil)	SOT97-1
TEA1623PH	DIP16	plastic dual in-line package; 16 leads (300 mil); long body	SOT38-1

## 6. Block diagram

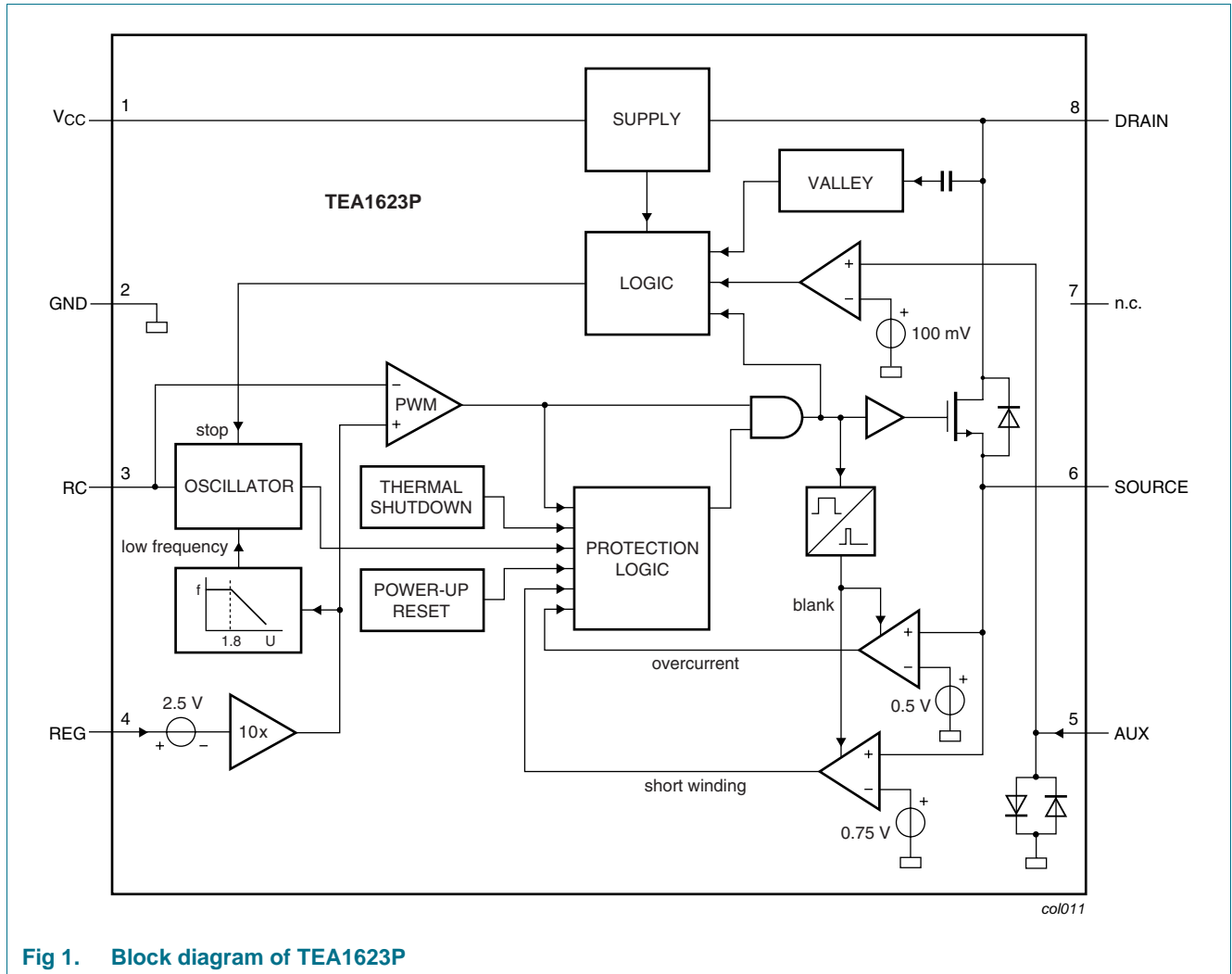

Fig 1. Block diagram of TEA1623P

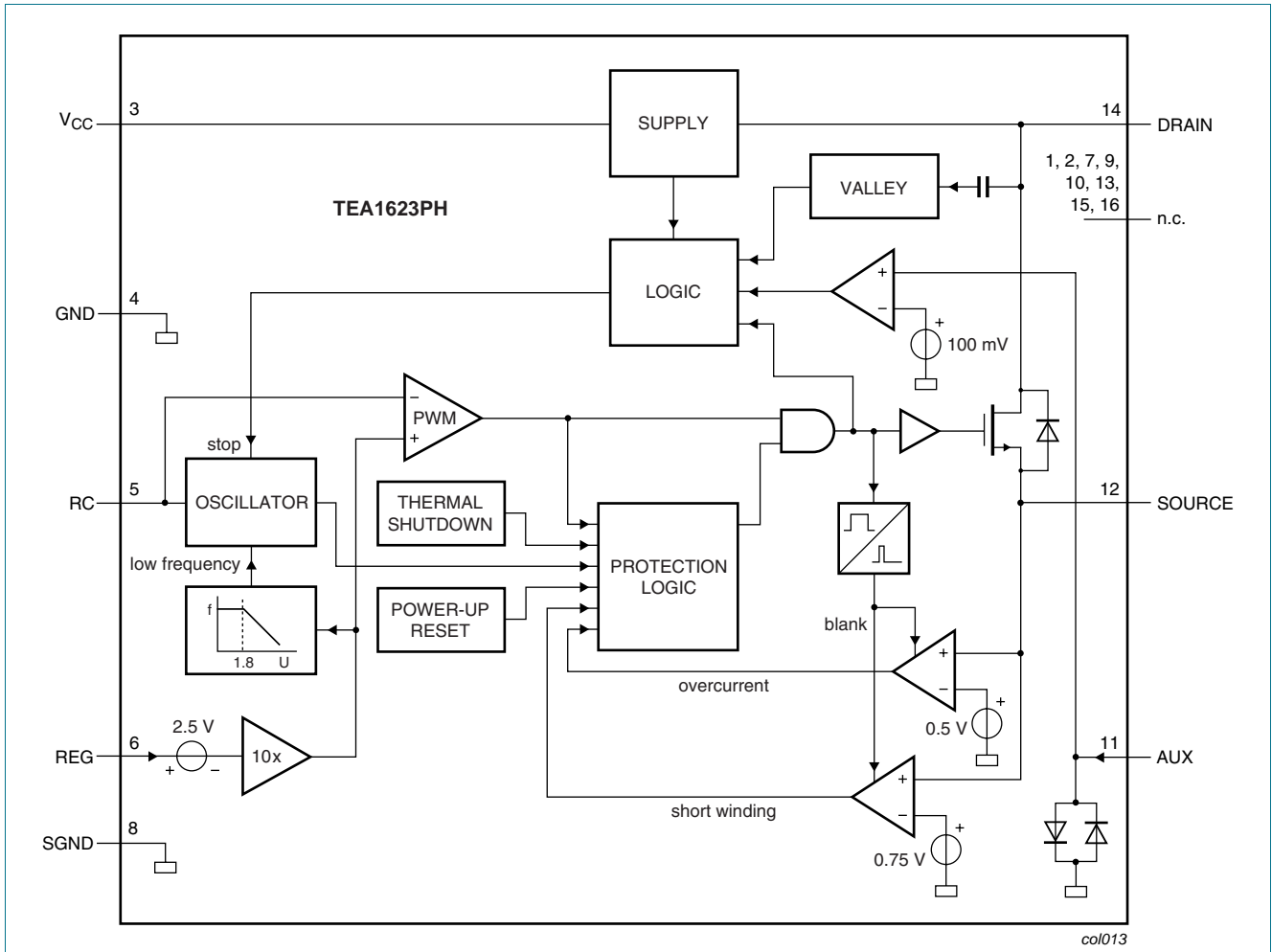

Fig 2. Block diagram of TEA1623PH

## 7. Pinning information

### 7.1 Pinning

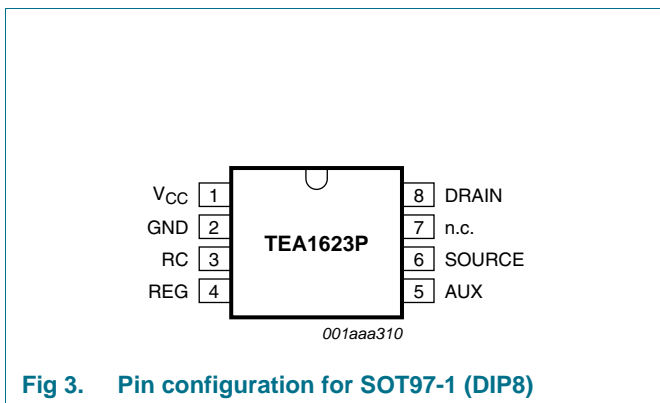

Fig 3. Pin configuration for SOT97-1 (DIP8)

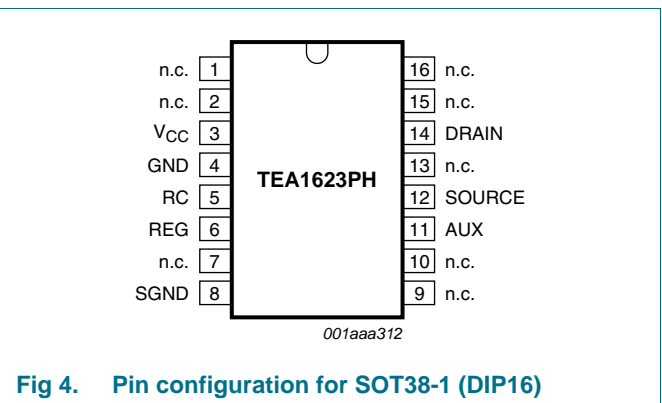

Fig 4. Pin configuration for SOT38-1 (DIP16)

## 7.2 Pin description

Table 3. Pin description

Symbol	Pin		Description
	TEA1623P	TEA1623PH	
V <sub>CC</sub>	1	3	supply voltage
GND	2	4	ground
RC	3	5	frequency setting
REG	4	6	regulation point
SGND	-	8	signal ground; preferably connected to pin GND
AUX	5	11	input for voltage from auxiliary winding for timing (demagnetization)
SOURCE	6	12	source of internal MOS switch
n.c.	7	1, 2, 7, 9, 10, 13, 15, 16	not connected
DRAIN	8	14	drain of internal MOS switch; input for start-up current and valley sensing

## 8. Functional description

The TEA1623 is the heart of a compact flyback converter, with the IC placed at the primary side. The auxiliary winding of the transformer can be used for indirect feedback to control the isolated output. This additional winding also powers the IC. A more accurate control of the output voltage and/or current can be implemented with an additional secondary sensing circuit and optocoupler feedback.

The TEA1623 uses voltage mode control. The frequency is determined by the maximum transformer demagnetizing time or the frequency of the oscillator. In the first case, the converter operates in the Self Oscillating Power Supply (SOPS) mode. In the latter case, it operates at a constant frequency, which can be adjusted with external components R<sub>RC</sub> and C<sub>RC</sub>. This mode is called Pulse Width Modulation (PWM). Furthermore, a primary stroke is started only in a valley of the secondary ringing. This valley switching principle minimizes capacitive switch-on losses.

### 8.1 Start-up and UnderVoltage LockOut (UVLO)

Initially, the IC is self supplying from the rectified mains voltage. The IC starts switching as soon as the voltage on pin V<sub>CC</sub> passes the V<sub>CC(start)</sub> level. The supply is taken over by the auxiliary winding of the transformer as soon as V<sub>CC</sub> is high enough and the supply from the line is stopped for high efficiency operation.

As soon as the voltage on pin V<sub>CC</sub> drops below the V<sub>CC(stop)</sub> level, the IC stops switching and restarts from the rectified mains voltage.

### 8.2 Oscillator

The frequency of the oscillator is set by the external resistor and capacitor on pin RC. The external capacitor is charged rapidly to the V<sub>RC(max)</sub> level and, starting from a new primary stroke, it discharges to the V<sub>RC(min)</sub> level. Because the discharge is exponential, the

relative sensitivity of the duty factor to the regulation voltage at low duty factor is almost equal to the sensitivity at high duty factors. This results in a more constant gain over the duty factor range compared to PWM systems with a linear sawtooth oscillator. Stable operation at low duty factors is easily realized. For high efficiency, the frequency is reduced as soon as the duty factor drops below a certain value. This is accomplished by increasing the oscillator charge time.

To ensure that the capacitor can be charged within the charge time, the value of the oscillator capacitor should be limited to approximately 1 nF.

### 8.3 Duty factor control

The duty factor is controlled by the internal regulation voltage and the oscillator signal on pin RC. The internal regulation voltage is equal to the external regulation voltage ( $-2.5\text{ V}$ ) multiplied by the gain of the error amplifier (typical 20 dB or  $10\times$ ).

The minimum duty factor of the switched mode power supply is 0 %. The maximum duty factor is set to 75 % (typical value at 100 kHz oscillation frequency).

### 8.4 Valley switching

A new cycle is started at the primary stroke when the switch is switched on (see [Figure 5](#)). After a certain time (determined by the RC oscillator voltage and the internal regulation level), the switch is turned off and the secondary stroke starts. The internal regulation level is determined by the voltage on pin REG. After the secondary stroke, the drain voltage shows an oscillation with a frequency of approximately  $\frac{I}{2\pi \times \sqrt{L_p C_p}}$ , where:

$L_p$  is the primary self inductance on the drain node.

$C_p$  is the parasitic capacitance on the drain node.

As soon as the oscillator voltage is high again and the secondary stroke has ended, the circuit waits for a low drain voltage before starting a new primary stroke.

The primary stroke starts some time before the actual valley at low ringing frequencies, and some time after the actual valley at high ringing frequencies. [Figure 6](#) shows a typical curve for a reflected voltage  $N \times V_o$  of 80 V. This voltage is the output voltage  $V_o$  (see [Figure 7](#)) transferred to the primary side of the transformer with the factor  $N$  (determined by the turns ratio of the transformer). [Figure 6](#) shows that the system switches exactly at minimum drain voltage for ringing frequencies of 480 kHz, thus reducing the switch-on losses to a minimum. At 200 kHz, the next primary stroke is started at  $33^\circ$  before the valley. The switch-on losses are still reduced significantly.

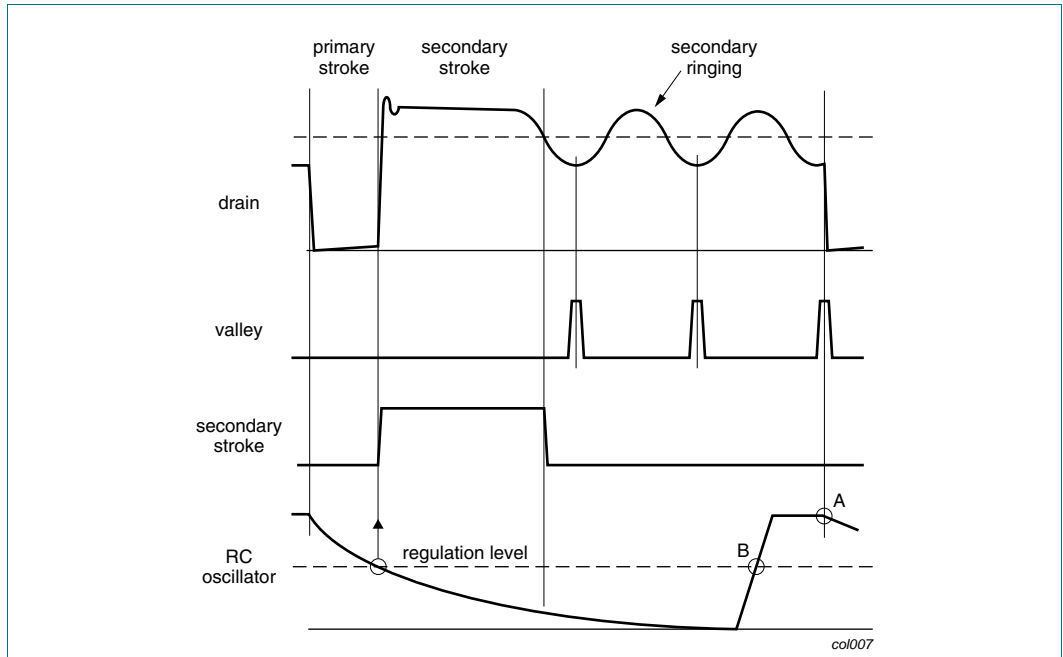

A: Start of new cycle with valley switching.  
 B: Start of new cycle in a classical PWM system.

Fig 5. Signals for valley switching

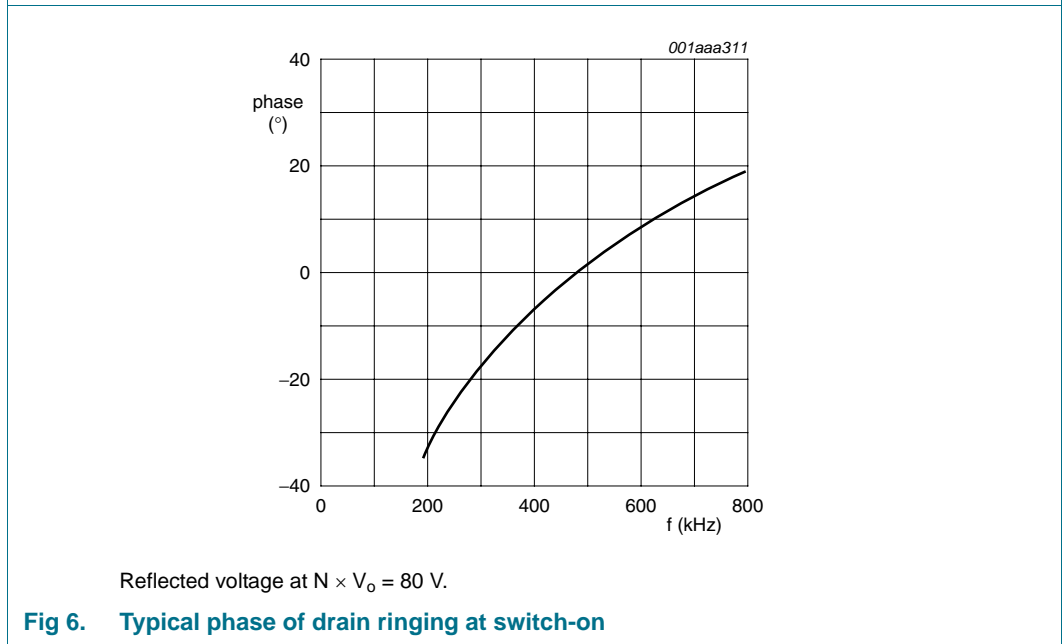

Reflected voltage at  $N \times V_o = 80$  V.

Fig 6. Typical phase of drain ringing at switch-on

### 8.5 Demagnetization

The system operates in discontinuous conduction mode all the time. As long as the secondary stroke has not ended, the oscillator will not start a new primary stroke. During the suppression time  $t_{suppr}$ , demagnetization recognition is suppressed. This suppression may be necessary in applications where the transformer has a large leakage inductance and at low output voltages.

## 8.6 Protection

### 8.6.1 Overcurrent protection

The cycle-by-cycle peak drain current limit circuit uses the external source resistor  $R_I$  (see [Figure 7](#)) to measure the current. The circuit is activated after the leading edge blanking time  $t_{leb}$ . The protection circuit limits the source voltage to  $V_{source(max)}$ , and thus limits the primary peak current.

### 8.6.2 Short-winding protection

The short-winding protection circuit is also activated after the leading edge blanking time. If the source voltage exceeds the short-winding protection voltage  $V_{swp}$ , the TEA1623 stops switching. Only a power-on reset will restart normal operation. The short-winding protection also protects in case of a secondary diode short circuit.

### 8.6.3 OverTemperature Protection (OTP)

An accurate temperature protection is provided in the TEA1623. When the junction temperature exceeds the thermal shut-down temperature, the IC stops switching. During thermal protection, the IC current is lowered to the start-up current. The IC continues normal operation as soon as the overtemperature situation has disappeared.

### 8.6.4 OverVoltage Protection (OVP)

Overvoltage protection can be achieved in the application by pulling pin REG above its normal operation level, or by keeping the level of pin AUX above  $V_{demag}$ . The current primary stroke is terminated immediately and no new primary stroke is started until the voltage on pin REG drops to its normal operation level. Pin REG has an internal clamp. The current feed into pin REG must be limited.

## 8.7 Characteristics of the complete power-plug

### 8.7.1 Input

The input voltage range comprises the universal AC mains from 80 V to 276 V.

### 8.7.2 Accuracy

The accuracy of the complete converter, functioning as a voltage source with primary sensing, is approximately 8 % (mainly dependent on the transformer coupling). The accuracy with secondary sensing is defined by the accuracy of the external components. For safety requirements in case of optocoupler feedback loss, the primary sensing remains active when an overvoltage circuit is connected.

### 8.7.3 Efficiency

An efficiency of 75 % at maximum output power can be achieved for a complete converter designed for universal mains.

### 8.7.4 Ripple

A minimum ripple is obtained in a system designed for a maximum duty factor of 50 % under normal operating conditions and a minimized dead time. The magnitude of the ripple in the output voltage is determined by the frequency and duty factor of the converter, the output current level, and the value and ESR of the output capacitor.

## 9. Limiting values

**Table 4. Limiting values**
*In accordance with the Absolute Maximum Rating System (IEC 60134).*

Symbol	Parameter	Conditions	Min	Max	Unit
<b>Voltage</b>					
V <sub>CC</sub>	supply voltage	continuous	[1] -0.4	+40	V
V <sub>RC</sub>	oscillator input voltage		[1] -0.4	+3	V
V <sub>SOURCE</sub>	DMOS power transistor source voltage		-0.4	+5	V
V <sub>DRAIN</sub>	DMOS power transistor drain voltage	T <sub>j</sub> > 0 °C	-0.4	+650	V
<b>Current</b>					
I <sub>REG</sub>	regulation input current		[2] -	6	mA
I <sub>AUX</sub>	auxiliary winding input current		[2] -10	+5	mA
I <sub>RC</sub>	oscillator capacitor charge current		-3	-	mA
I <sub>SOURCE</sub>	source current		-2	+2	A
I <sub>DRAIN</sub>	drain current		-2	+2	A
<b>General</b>					
P <sub>tot</sub>	total power dissipation	TEA1623P; T <sub>amb</sub> < 45 °C	-	1.0	W
		TEA1623PH; T <sub>amb</sub> < 50 °C	-	1.7	W
T <sub>stg</sub>	storage temperature		-55	+150	°C
T <sub>j</sub>	junction temperature		-20	+145	°C
V <sub>ESD</sub>	electrostatic discharge voltage	human body model[3]			
		pin DRAIN	-1500	+1500	V
		all other pins	-2000	+2000	V
		machine model[4]			
	all pins		-200	+200	V

[1] Pins V<sub>CC</sub> and RC are not allowed to be current driven.

[2] Pins REG and AUX are not allowed to be voltage driven.

[3] Human body model: equivalent to discharging a 100 pF capacitor through a 1.5 kΩ series resistor.

[4] Machine model: equivalent to discharging a 200 pF capacitor through a 0.75 μH coil and a 10 Ω series resistor.

## 10. Thermal characteristics

**Table 5. Thermal characteristics**

Symbol	Parameter	Conditions	Typ	Unit
R <sub>th(j-a)</sub>	thermal resistance from junction to ambient	in free air	[1]	-
		TEA1623P	100	K/W
		TEA1623PH	55	K/W

[1] Thermal resistance R<sub>th(j-a)</sub> can be lower when pin GND is connected to sufficient copper area on the printed-circuit board. See the TEA152x application note for details.

## 11. Characteristics

**Table 6. Characteristics**

$T_{amb} = 25\text{ °C}$ ; no overtemperature; all voltages are measured with respect to ground; currents are positive when flowing into the IC, unless otherwise specified.

Symbol	Parameter	Conditions	Min	Typ	Max	Unit
<b>Supplies</b>						
Supply on pin $V_{CC}$						
$V_{CC(start)}$	start voltage		9	9.5	10	V
$V_{CC(stop)}$	stop voltage	undervoltage lockout	7.0	7.5	8.0	V
$I_{CC(operate)}$	operating supply current	normal operation	-	1.3	1.9	mA
$I_{CC(startup)}$	start-up supply current	start-up	-	180	400	$\mu$ A
$I_{CC(ch)}$	charging current	$V_{DRAIN} > 60\text{ V}$				
		$V_{CC} = 0\text{ V}$	-650	-520	-390	$\mu$ A
		$V_{CC} = 8.5\text{ V}$	-375	-275	-175	$\mu$ A
Supply on pin DRAIN						
$I_{DRAIN}$	supply current drawn from pin DRAIN	no auxiliary supply	-	0.5	-	mA
		with auxiliary supply; $V_{DRAIN} > 60\text{ V}$	-	30	125	$\mu$ A
<b>PWM mode</b>						
$\delta_{min}$	minimum duty factor		-	0	-	%
$\delta_{max}$	maximum duty factor	$f_{osc} = 100\text{ kHz}$	-	75	-	%
<b>Self-oscillating power supply mode</b>						
$V_{demag}$	demagnetization recognition voltage level		50	100	150	mV
$t_{suppr}$	time of suppression of transformer ringing at start of secondary stroke		1.0	1.5	2.0	$\mu$ s
<b>Oscillator: pin RC</b>						
$V_{RC(min)}$	minimum voltage of RC oscillator setting		60	75	90	mV
$V_{RC(max)}$	maximum voltage of RC oscillator setting		2.4	2.5	2.6	V
$t_{RC(ch)}$	RC charging time		-	1	-	$\mu$ s
$f_{osc}$	oscillator frequency range		10	-	200	kHz
<b>Duty factor regulator: pin REG</b>						
$V_{REG}$	input voltage on pin REG		2.4	2.5	2.6	V
$G_{V(erroramp)}$	voltage gain of error amplifier		-	20	-	dB
$V_{REG(clamp)}$	clamping voltage on pin REG	$I_{REG} = 6\text{ mA}$	-	-	7.5	V
<b>Valley switching recognition</b>						
$dV/dt_{valley}$	valley recognition		-102	-	+102	V/ $\mu$ s
$f_{valley}$	ringing frequency for valley switching	$N \times V_o = 100\text{ V}$	200	550	800	kHz
$t_{d(valley-on)}$	delay from valley recognition to switch-on		-	150	-	ns
<b>Output stage (FET)</b>						
$I_{L(drain)}$	drain leakage current	$V_{DRAIN} = 650\text{ V}$	-	-	125	$\mu$ A

**Table 6. Characteristics ...continued**

$T_{amb} = 25\text{ }^{\circ}\text{C}$ ; no overtemperature; all voltages are measured with respect to ground; currents are positive when flowing into the IC, unless otherwise specified.

Symbol	Parameter	Conditions	Min	Typ	Max	Unit
$V_{BR(drain)}$	drain breakdown voltage	$T_j > 0\text{ }^{\circ}\text{C}$	650	-	-	V
$R_{DSon}$	drain-source on-state resistance	$I_{SOURCE} = -0.5\text{ A}$				
		$T_j = 25\text{ }^{\circ}\text{C}$	-	6.5	7.5	$\Omega$
		$T_j = 100\text{ }^{\circ}\text{C}$	-	9.0	10.0	$\Omega$
$t_{drain(f)}$	drain fall time	$V_{DRAIN(switch\_on)} = 300\text{ V}$ ; no external capacitor at pin DRAIN	-	75	-	ns

**Temperature protection**

$T_{prot(max)}$	maximum threshold temperature		150	160	170	$^{\circ}\text{C}$
$T_{prot(hys)}$	threshold temperature hysteresis		-	2	-	$^{\circ}\text{C}$

**Overcurrent and short winding protection: pin SOURCE**

$V_{source(max)}$	overcurrent protection voltage	$dV/dt = 0.1\text{ V}/\mu\text{s}$	0.47	0.50	0.53	V
$V_{swp}$	short-winding protection voltage	$dV/dt = 0.5\text{ V}/\mu\text{s}$	0.7	0.75	0.8	V
$t_{d(propagation)}$	delay from detecting $V_{source(max)}$ to switch-off	$dV/dt = 0.5\text{ V}/\mu\text{s}$	-	160	185	ns
$t_{leb}$	leading edge blanking time	overcurrent and short-winding protection	250	350	450	ns

**12. Application information**

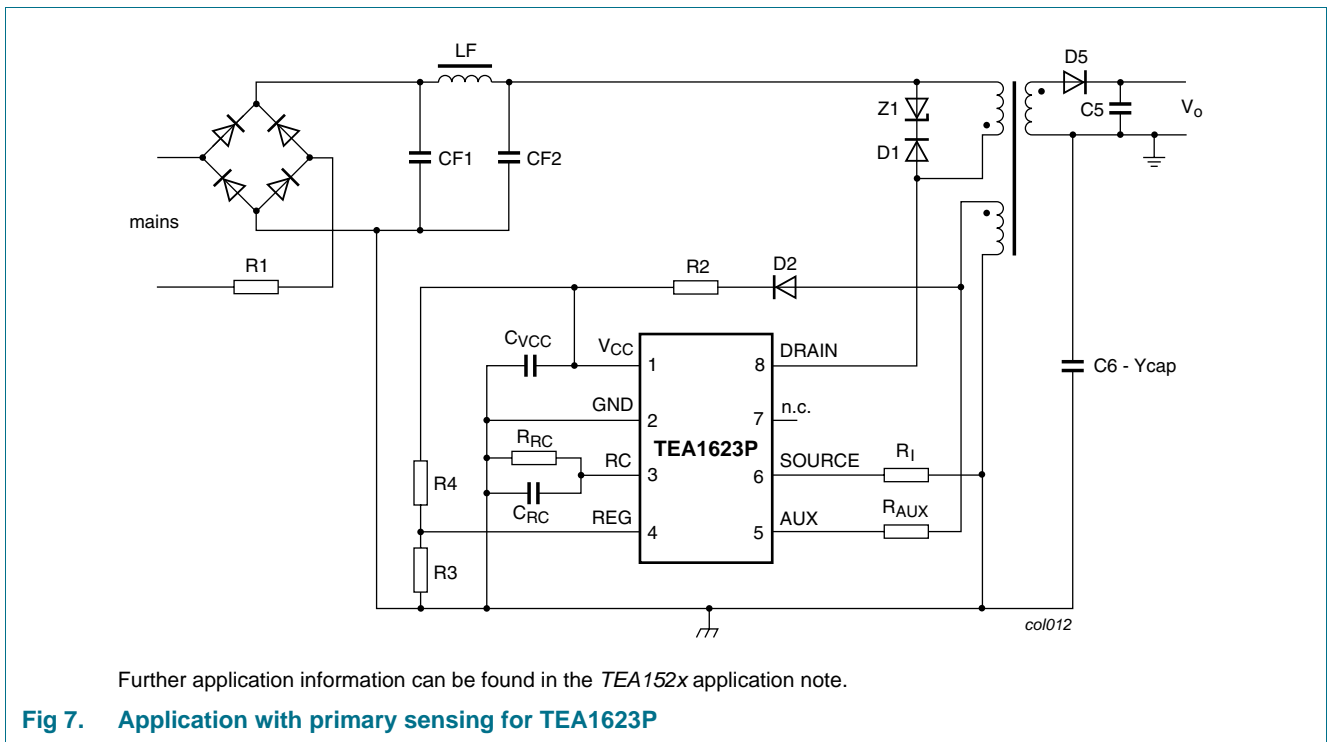

13. Package outline

DIP8: plastic dual in-line package; 8 leads (300 mil)

SOT97-1

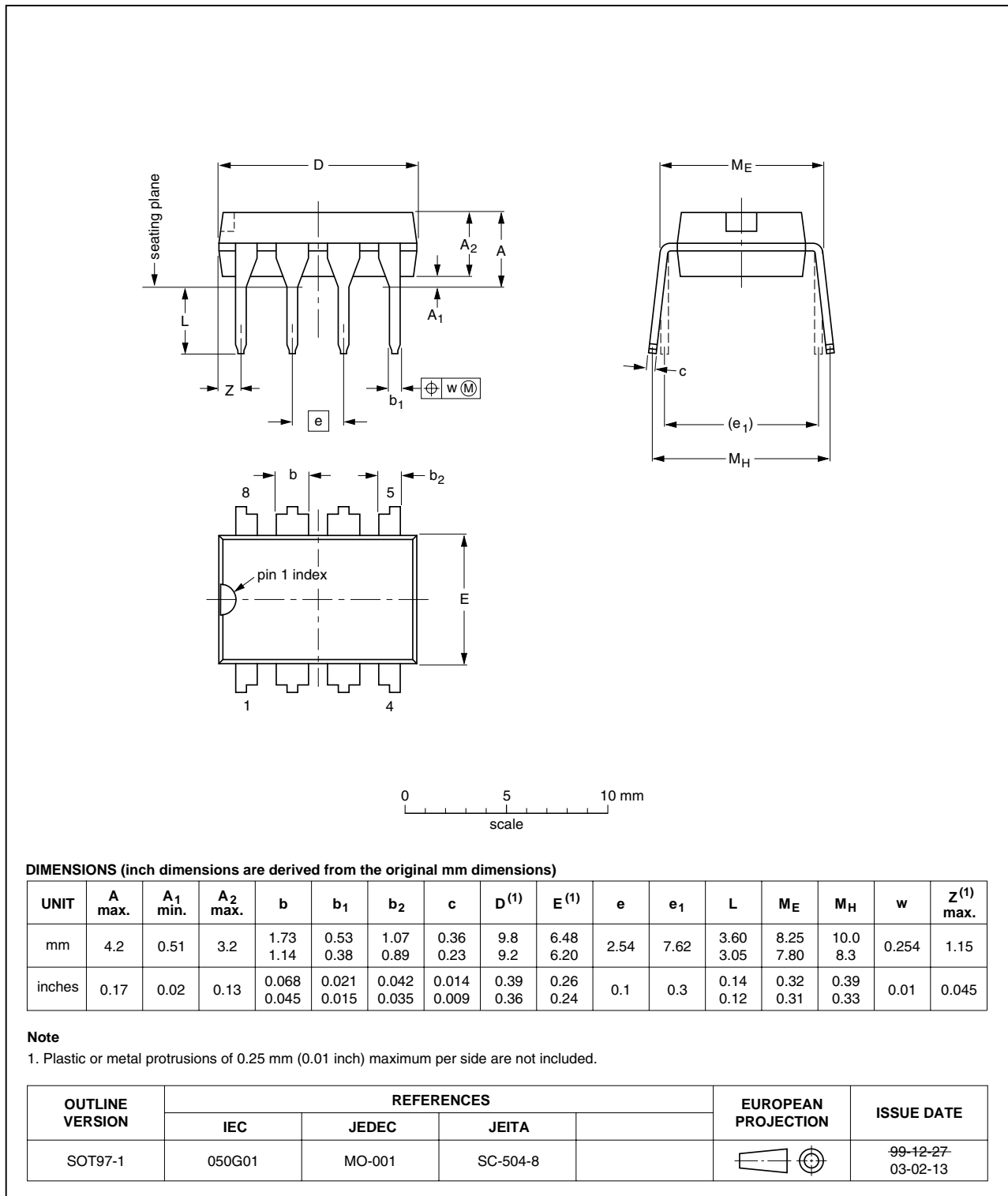

Fig 8. Package outline SOT97-1 (DIP8)

DIP16: plastic dual in-line package; 16 leads (300 mil); long body

SOT38-1

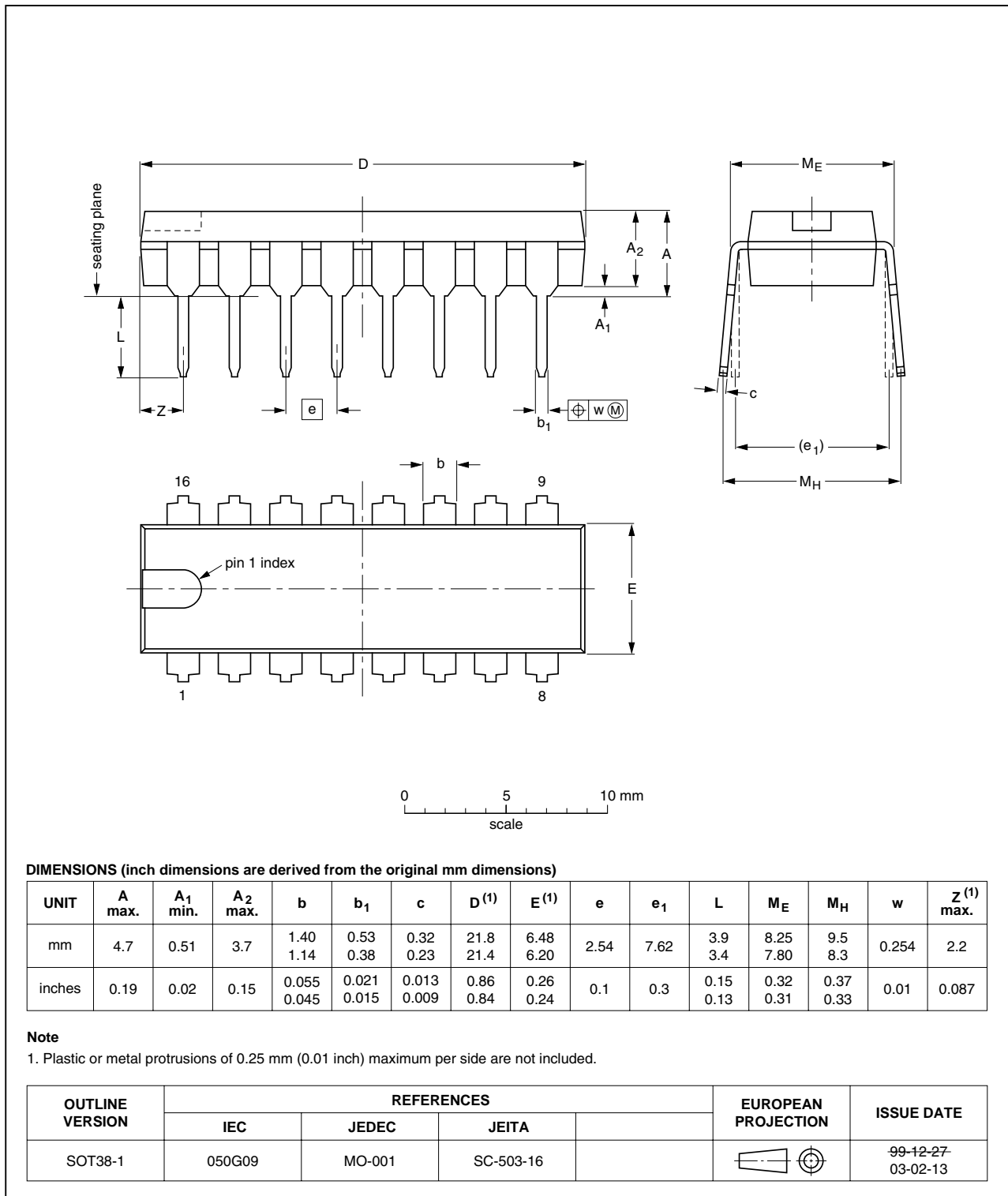

Fig 9. Package outline SOT38-1 (DIP16)

## 14. Soldering of through-hole mount packages

### 14.1 Introduction to soldering through-hole mount packages

This text gives a very brief insight into wave, dip and manual soldering.

Wave soldering is the preferred method for mounting of through-hole mount IC packages on a printed-circuit board.

### 14.2 Soldering by dipping or by solder wave

Driven by legislation and environmental forces the worldwide use of lead-free solder pastes is increasing. Typical dwell time of the leads in the wave ranges from 3 seconds to 4 seconds at 250 °C or 265 °C, depending on solder material applied, SnPb or Pb-free respectively.

The total contact time of successive solder waves must not exceed 5 seconds.

The device may be mounted up to the seating plane, but the temperature of the plastic body must not exceed the specified maximum storage temperature ( $T_{stg(max)}$ ). If the printed-circuit board has been pre-heated, forced cooling may be necessary immediately after soldering to keep the temperature within the permissible limit.

### 14.3 Manual soldering

Apply the soldering iron (24 V or less) to the lead(s) of the package, either below the seating plane or not more than 2 mm above it. If the temperature of the soldering iron bit is less than 300 °C it may remain in contact for up to 10 seconds. If the bit temperature is between 300 °C and 400 °C, contact may be up to 5 seconds.

### 14.4 Package related soldering information

**Table 7. Suitability of through-hole mount IC packages for dipping and wave soldering**

Package	Soldering method	
	Dipping	Wave
CPGA, HCPGA	-	suitable
DBS, DIP, HDIP, RDBS, SDIP, SIL	suitable	suitable <sup>[1]</sup>
PMFP <sup>[2]</sup>	-	not suitable

[1] For SDIP packages, the longitudinal axis must be parallel to the transport direction of the printed-circuit board.

[2] For PMFP packages hot bar soldering or manual soldering is suitable.

## 15. Abbreviations

Table 8. Abbreviations

Acronym	Description
BiCMOS	Bipolar CMOS
CMOS	Complementary Metal-Oxide Semiconductor
DMOS	Diffusion Metal-Oxide Semiconductor
ESR	Equivalent Series Resistance
OCP	OverCurrent Protection
OTP	OverTemperature Protection
OVP	OverVoltage Protection
PWM	Pulse Width Modulation
SMPS	Switched Mode Power Supply
SOI	Silicon On Insulator
SOPS	Self Oscillating Power Supply
STB	Set-Top Box
UVLO	UnderVoltage LockOut
UVP	UnderVoltage Protection
VCD	Video Compact Disc

## 16. Revision history

Table 9. Revision history

Document ID	Release date	Data sheet status	Change notice	Supersedes
TEA1623P_TEA1623PH v.3	20100830	Product data sheet	-	TEA1623P_TEA1623PH_2
Modifications:	<ul style="list-style-type: none"> <li>• <a href="#">Table 1</a> "Quick reference data" updated.</li> <li>• <a href="#">Table 4</a> "Limiting values" updated.</li> </ul>			
TEA1623P_TEA1623PH_2	20091104	Product data sheet	-	TEA1623P_TEA1623PH_1
Modifications:	<ul style="list-style-type: none"> <li>• The format of this data sheet has been redesigned to comply with the new identity guidelines of NXP Semiconductors.</li> <li>• Legal texts have been adapted to the new company name where appropriate.</li> <li>• Pin configuration drawing A and B split into <a href="#">Figure 3 "Pin configuration for SOT97-1 (DIP8)"</a> and <a href="#">Figure 4 "Pin configuration for SOT38-1 (DIP16)"</a>.</li> <li>• <a href="#">Section 15 "Abbreviations"</a> added.</li> </ul>			
TEA1623P_TEA1623PH_1	20040317	Product data sheet	-	-

## 17. Legal information

### 17.1 Data sheet status

Document status <sup>[1][2]</sup>	Product status <sup>[3]</sup>	Definition
Objective [short] data sheet	Development	This document contains data from the objective specification for product development.
Preliminary [short] data sheet	Qualification	This document contains data from the preliminary specification.
Product [short] data sheet	Production	This document contains the product specification.

[1] Please consult the most recently issued document before initiating or completing a design.

[2] The term 'short data sheet' is explained in section "Definitions".

[3] The product status of device(s) described in this document may have changed since this document was published and may differ in case of multiple devices. The latest product status information is available on the Internet at URL <http://www.nxp.com>.

### 17.2 Definitions

**Draft** — The document is a draft version only. The content is still under internal review and subject to formal approval, which may result in modifications or additions. NXP Semiconductors does not give any representations or warranties as to the accuracy or completeness of information included herein and shall have no liability for the consequences of use of such information.

**Short data sheet** — A short data sheet is an extract from a full data sheet with the same product type number(s) and title. A short data sheet is intended for quick reference only and should not be relied upon to contain detailed and full information. For detailed and full information see the relevant full data sheet, which is available on request via the local NXP Semiconductors sales office. In case of any inconsistency or conflict with the short data sheet, the full data sheet shall prevail.

**Product specification** — The information and data provided in a Product data sheet shall define the specification of the product as agreed between NXP Semiconductors and its customer, unless NXP Semiconductors and customer have explicitly agreed otherwise in writing. In no event however, shall an agreement be valid in which the NXP Semiconductors product is deemed to offer functions and qualities beyond those described in the Product data sheet.

### 17.3 Disclaimers

**Limited warranty and liability** — Information in this document is believed to be accurate and reliable. However, NXP Semiconductors does not give any representations or warranties, expressed or implied, as to the accuracy or completeness of such information and shall have no liability for the consequences of use of such information.

In no event shall NXP Semiconductors be liable for any indirect, incidental, punitive, special or consequential damages (including - without limitation - lost profits, lost savings, business interruption, costs related to the removal or replacement of any products or rework charges) whether or not such damages are based on tort (including negligence), warranty, breach of contract or any other legal theory.

Notwithstanding any damages that customer might incur for any reason whatsoever, NXP Semiconductors' aggregate and cumulative liability towards customer for the products described herein shall be limited in accordance with the *Terms and conditions of commercial sale* of NXP Semiconductors.

**Right to make changes** — NXP Semiconductors reserves the right to make changes to information published in this document, including without limitation specifications and product descriptions, at any time and without notice. This document supersedes and replaces all information supplied prior to the publication hereof.

**Suitability for use** — NXP Semiconductors products are not designed, authorized or warranted to be suitable for use in life support, life-critical or safety-critical systems or equipment, nor in applications where failure or

malfunction of an NXP Semiconductors product can reasonably be expected to result in personal injury, death or severe property or environmental damage. NXP Semiconductors accepts no liability for inclusion and/or use of NXP Semiconductors products in such equipment or applications and therefore such inclusion and/or use is at the customer's own risk.

**Applications** — Applications that are described herein for any of these products are for illustrative purposes only. NXP Semiconductors makes no representation or warranty that such applications will be suitable for the specified use without further testing or modification.

Customers are responsible for the design and operation of their applications and products using NXP Semiconductors products, and NXP Semiconductors accepts no liability for any assistance with applications or customer product design. It is customer's sole responsibility to determine whether the NXP Semiconductors product is suitable and fit for the customer's applications and products planned, as well as for the planned application and use of customer's third party customer(s). Customers should provide appropriate design and operating safeguards to minimize the risks associated with their applications and products.

NXP Semiconductors does not accept any liability related to any default, damage, costs or problem which is based on any weakness or default in the customer's applications or products, or the application or use by customer's third party customer(s). Customer is responsible for doing all necessary testing for the customer's applications and products using NXP Semiconductors products in order to avoid a default of the applications and the products or of the application or use by customer's third party customer(s). NXP does not accept any liability in this respect.

**Limiting values** — Stress above one or more limiting values (as defined in the Absolute Maximum Ratings System of IEC 60134) will cause permanent damage to the device. Limiting values are stress ratings only and (proper) operation of the device at these or any other conditions above those given in the Recommended operating conditions section (if present) or the Characteristics sections of this document is not warranted. Constant or repeated exposure to limiting values will permanently and irreversibly affect the quality and reliability of the device.

**Terms and conditions of commercial sale** — NXP Semiconductors products are sold subject to the general terms and conditions of commercial sale, as published at <http://www.nxp.com/profile/terms>, unless otherwise agreed in a valid written individual agreement. In case an individual agreement is concluded only the terms and conditions of the respective agreement shall apply. NXP Semiconductors hereby expressly objects to applying the customer's general terms and conditions with regard to the purchase of NXP Semiconductors products by customer.

**No offer to sell or license** — Nothing in this document may be interpreted or construed as an offer to sell products that is open for acceptance or the grant, conveyance or implication of any license under any copyrights, patents or other industrial or intellectual property rights.

**Export control** — This document as well as the item(s) described herein may be subject to export control regulations. Export might require a prior authorization from national authorities.

**Quick reference data** — The Quick reference data is an extract of the product data given in the Limiting values and Characteristics sections of this document, and as such is not complete, exhaustive or legally binding.

**Non-automotive qualified products** — Unless this data sheet expressly states that this specific NXP Semiconductors product is automotive qualified, the product is not suitable for automotive use. It is neither qualified nor tested in accordance with automotive testing or application requirements. NXP Semiconductors accepts no liability for inclusion and/or use of non-automotive qualified products in automotive equipment or applications.

In the event that customer uses the product for design-in and use in automotive applications to automotive specifications and standards, customer (a) shall use the product without NXP Semiconductors' warranty of the

product for such automotive applications, use and specifications, and (b) whenever customer uses the product for automotive applications beyond NXP Semiconductors' specifications such use shall be solely at customer's own risk, and (c) customer fully indemnifies NXP Semiconductors for any liability, damages or failed product claims resulting from customer design and use of the product for automotive applications beyond NXP Semiconductors' standard warranty and NXP Semiconductors' product specifications.

## 17.4 Trademarks

Notice: All referenced brands, product names, service names and trademarks are the property of their respective owners.

## 18. Contact information

For more information, please visit: <http://www.nxp.com>

For sales office addresses, please send an email to: [salesaddresses@nxp.com](mailto:salesaddresses@nxp.com)

## 19. Tables

---

Table 1.	Quick reference data . . . . .	2
Table 2.	Ordering information . . . . .	2
Table 3.	Pin description . . . . .	5
Table 4.	Limiting values . . . . .	9
Table 5.	Thermal characteristics . . . . .	9
Table 6.	Characteristics . . . . .	10
Table 7.	Suitability of through-hole mount IC packages for dipping and wave soldering . . . .	14
Table 8.	Abbreviations . . . . .	15
Table 9.	Revision history . . . . .	15

**continued >>**

## 20. Figures

---

Fig 1.	Block diagram of TEA1623P	3
Fig 2.	Block diagram of TEA1623PH	4
Fig 3.	Pin configuration for SOT97-1 (DIP8)	4
Fig 4.	Pin configuration for SOT38-1 (DIP16)	4
Fig 5.	Signals for valley switching	7
Fig 6.	Typical phase of drain ringing at switch-on	7
Fig 7.	Application with primary sensing for TEA1623P	11
Fig 8.	Package outline SOT97-1 (DIP8)	12
Fig 9.	Package outline SOT38-1 (DIP16)	13

**continued >>**

## 21. Contents

<b>1</b>	<b>General description</b> . . . . .	<b>1</b>	<b>19</b>	<b>Tables</b> . . . . .	<b>18</b>
<b>2</b>	<b>Features and benefits</b> . . . . .	<b>1</b>	<b>20</b>	<b>Figures</b> . . . . .	<b>19</b>
<b>3</b>	<b>Applications</b> . . . . .	<b>1</b>	<b>21</b>	<b>Contents</b> . . . . .	<b>20</b>
<b>4</b>	<b>Quick reference data</b> . . . . .	<b>2</b>			
<b>5</b>	<b>Ordering information</b> . . . . .	<b>2</b>			
<b>6</b>	<b>Block diagram</b> . . . . .	<b>3</b>			
<b>7</b>	<b>Pinning information</b> . . . . .	<b>4</b>			
7.1	Pinning . . . . .	4			
7.2	Pin description . . . . .	5			
<b>8</b>	<b>Functional description</b> . . . . .	<b>5</b>			
8.1	Start-up and UnderVoltage LockOut (UVLO) . . . . .	5			
8.2	Oscillator . . . . .	5			
8.3	Duty factor control . . . . .	6			
8.4	Valley switching . . . . .	6			
8.5	Demagnetization . . . . .	7			
8.6	Protection . . . . .	8			
8.6.1	Overcurrent protection . . . . .	8			
8.6.2	Short-winding protection . . . . .	8			
8.6.3	OverTemperature Protection (OTP) . . . . .	8			
8.6.4	OverVoltage Protection (OVP) . . . . .	8			
8.7	Characteristics of the complete power-plug . . . . .	8			
8.7.1	Input . . . . .	8			
8.7.2	Accuracy . . . . .	8			
8.7.3	Efficiency . . . . .	8			
8.7.4	Ripple . . . . .	8			
<b>9</b>	<b>Limiting values</b> . . . . .	<b>9</b>			
<b>10</b>	<b>Thermal characteristics</b> . . . . .	<b>9</b>			
<b>11</b>	<b>Characteristics</b> . . . . .	<b>10</b>			
<b>12</b>	<b>Application information</b> . . . . .	<b>11</b>			
<b>13</b>	<b>Package outline</b> . . . . .	<b>12</b>			
<b>14</b>	<b>Soldering of through-hole mount packages</b> . . . . .	<b>14</b>			
14.1	Introduction to soldering through-hole mount packages . . . . .	14			
14.2	Soldering by dipping or by solder wave . . . . .	14			
14.3	Manual soldering . . . . .	14			
14.4	Package related soldering information . . . . .	14			
<b>15</b>	<b>Abbreviations</b> . . . . .	<b>15</b>			
<b>16</b>	<b>Revision history</b> . . . . .	<b>15</b>			
<b>17</b>	<b>Legal information</b> . . . . .	<b>16</b>			
17.1	Data sheet status . . . . .	16			
17.2	Definitions . . . . .	16			
17.3	Disclaimers . . . . .	16			
17.4	Trademarks . . . . .	17			
<b>18</b>	<b>Contact information</b> . . . . .	<b>17</b>			

Please be aware that important notices concerning this document and the product(s) described herein, have been included in section 'Legal information'.

© NXP B.V. 2010.

All rights reserved.

For more information, please visit: <http://www.nxp.com>

For sales office addresses, please send an email to: [salesaddresses@nxp.com](mailto:salesaddresses@nxp.com)

Date of release: 30 August 2010

Document identifier: TEA1623P\_TEA1623PH