

PCF8551

Universal 36 × 4 LCD segment driver

Rev. 2 — 16 February 2015

Product data sheet

1. General description

PCF8551 is an ultra low-power LCD segment driver with 4 backplane- and 36 segment-driver outputs, with either an I²C- (PCF8551A) or an SPI-bus (PCF8551B) interface. It comprises an internal oscillator, bias generation, instruction decoding, and display controller.

For a selection of NXP LCD segment drivers, see [Table 24 on page 45](#).

2. Features and benefits

- Single chip LCD controller and driver
- Selectable backplane drive configuration: static, 2, 3, or 4 backplane multiplexing
- Selectable display bias configuration: static, 1/2, or 1/3
- Internal LCD bias generation with buffers
- 36 segment drives:
 - ◆ Up to 18 7-segment numeric characters
 - ◆ Up to 9 14-segment alphanumeric characters
 - ◆ Any graphics of up to 144 segments/elements
- Auto-incrementing display data and instruction loading
- Versatile blinking modes
- Independent supplies of V_{LCD} and V_{DD}
- Power supply ranges:
 - ◆ 1.8 V to 5.5 V for V_{LCD}
 - ◆ 1.8 V to 5.5 V for V_{DD}
- Ultra low-power consumption
- 400 kHz I²C-bus interface (PCF8551A)
- 5 MHz SPI-bus interface (PCF8551B)
- Internally generated or externally supplied clock signal

3. Applications

- Metering equipment
- Consumer healthcare devices
- Battery operated devices
- Measuring equipment



4. Ordering information

Table 1. Ordering information

Type number	Package		
	Name	Description	Version
PCF8551ATT	TSSOP48	plastic thin shrink small outline package; 48 leads; body width 6.1 mm	SOT362-1
PCF8551BTT	TSSOP48	plastic thin shrink small outline package; 48 leads; body width 6.1 mm	SOT362-1

4.1 Ordering options

Table 2. Ordering options

Product type number	Orderable part number	Sales item (12NC)	Interface type	Delivery form	IC revision
PCF8551ATT/A	PCF8551ATT/AJ	935304761118	I ² C-bus	tape and reel, 13 inch	1
PCF8551BTT/A	PCF8551BTT/AJ	935305822118	SPI-bus	tape and reel, 13 inch	1

5. Marking

Table 3. Marking codes

Type number	Marking code
PCF8551ATT/A	PCF8551A
PCF8551BTT/A	PCF8551B

6. Block diagram

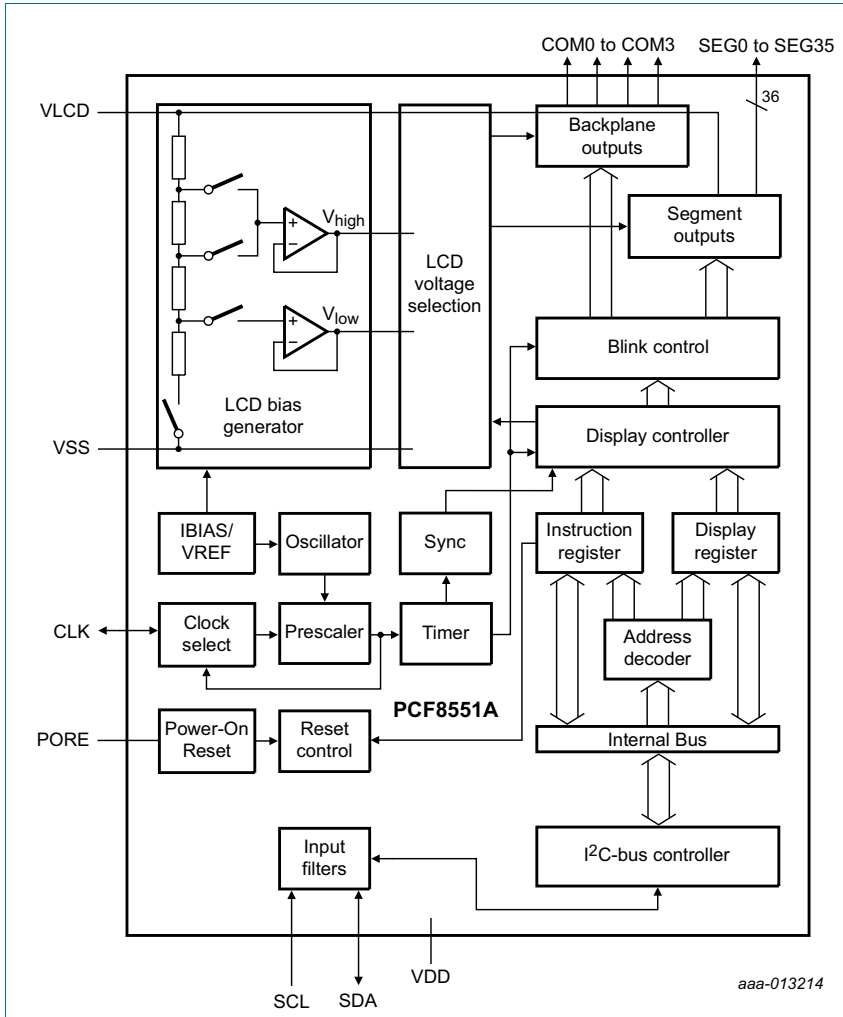

Fig 1. Block diagram of PCF8551A

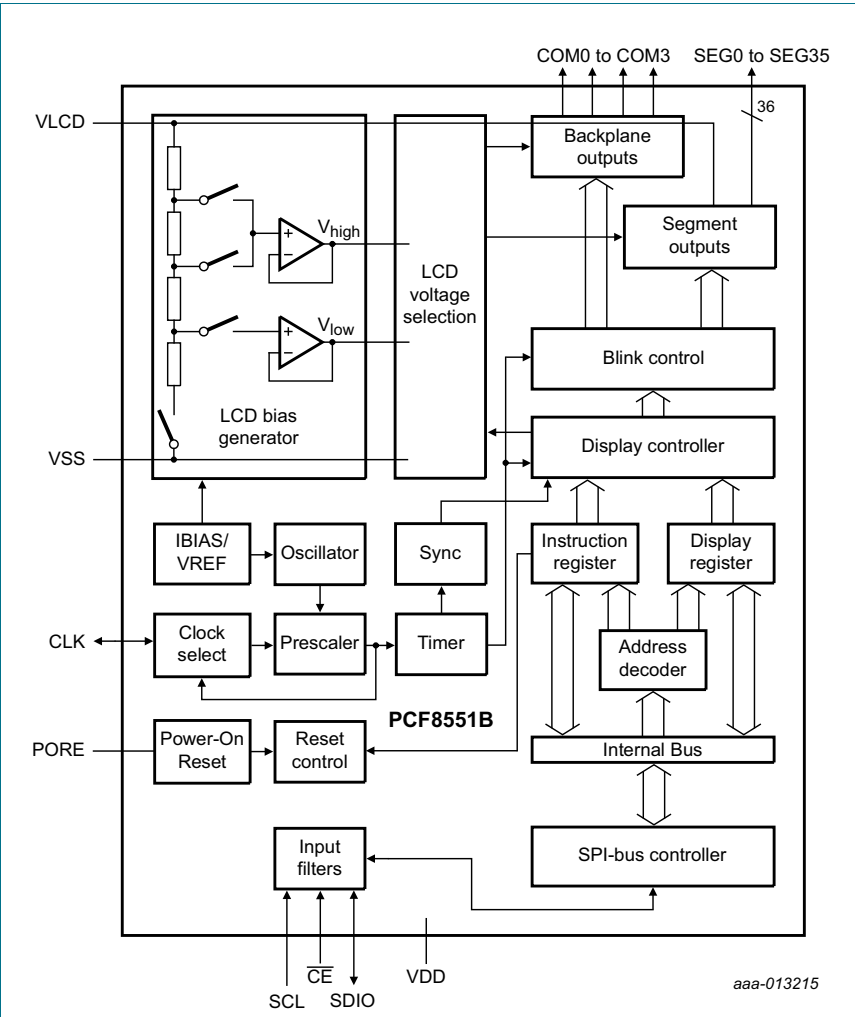
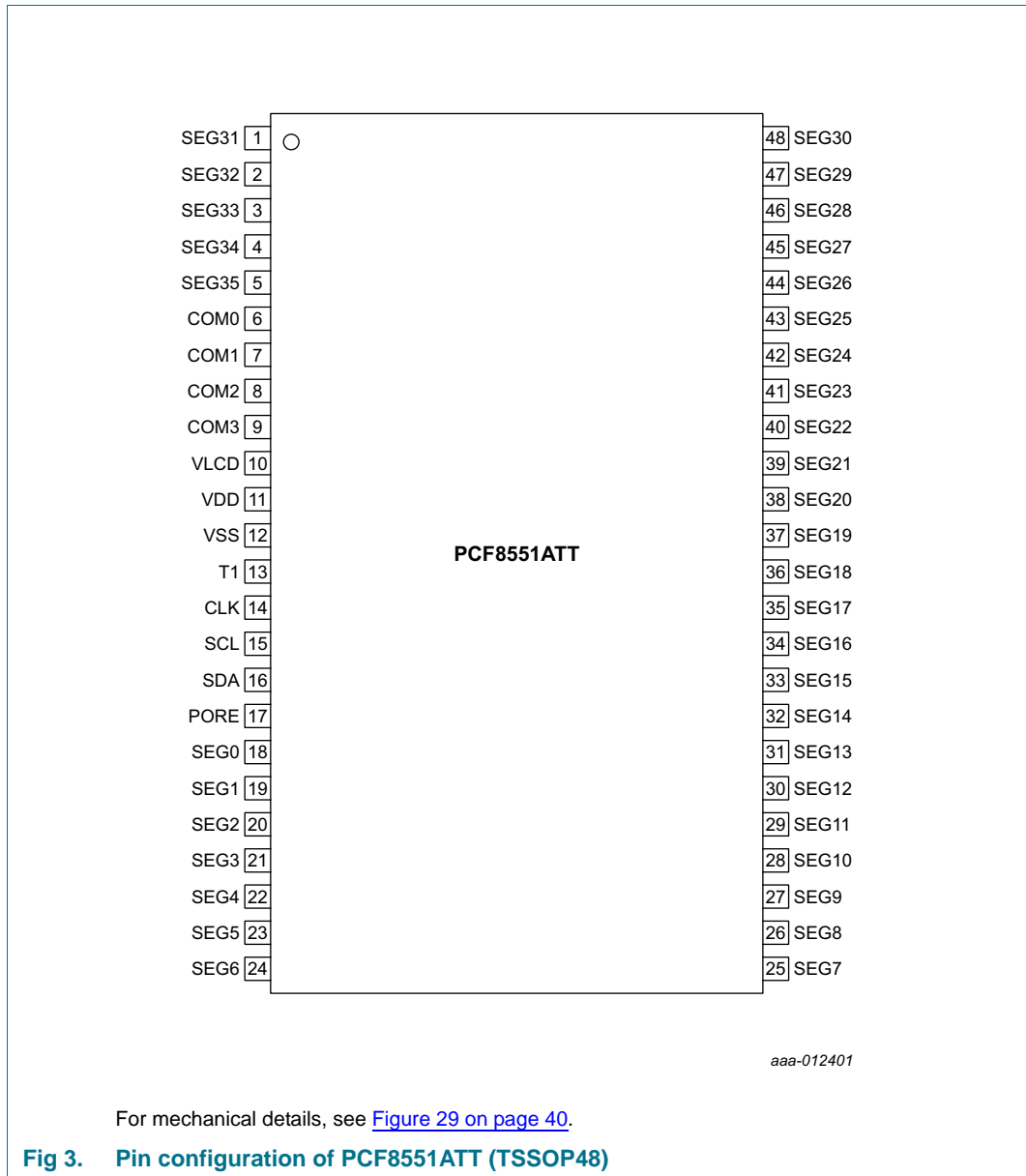
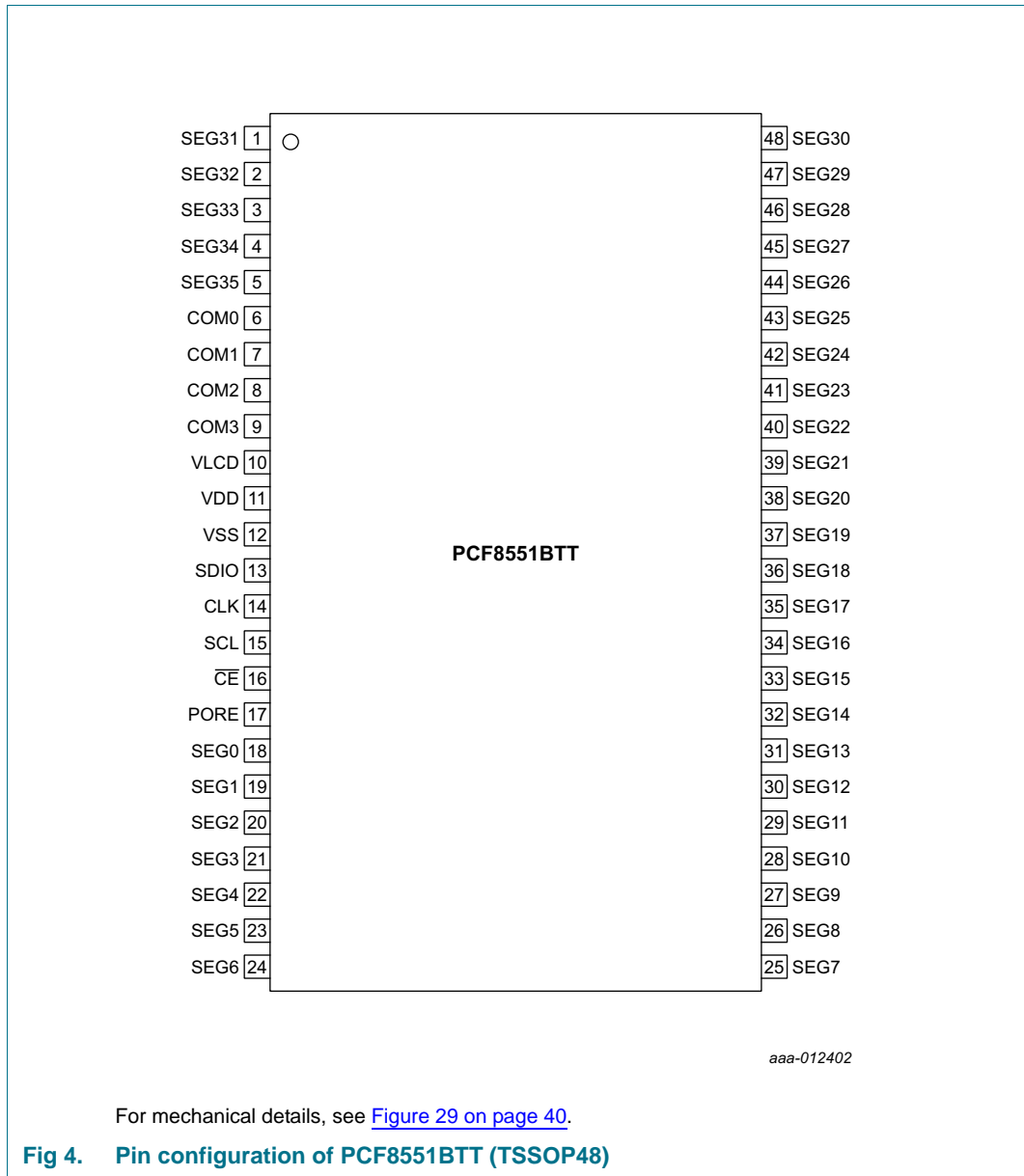

Fig 2. Block diagram of PCF8551B

7. Pinning information

7.1 Pinning





7.2 Pin description

Table 4. Pin description

Input or input/output pins must always be at a defined level (V_{SS} or V_{DD}) unless otherwise specified.

Pin	Symbol	Type	Description	
1 to 5, 18 to 48	SEG0 to SEG35	output	LCD segment outputs	
6 to 9	COM0 to COM3	output	LCD backplane outputs	
10	VLCD	supply	LCD supply voltage	
11	VDD	supply	supply voltage	
12	VSS	supply	ground supply	
14	CLK	input/output	internal oscillator output, external oscillator input ^[1] <ul style="list-style-type: none"> • must be left open if unused 	
15	SCL	input	serial clock input	
17	PORE ^[2]	input	Power-On Reset (POR) enable <ul style="list-style-type: none"> • connect to V_{DD} for enabling POR • connect to V_{SS} (or leave open) for disabling POR 	
Pin layout depending on product and bus type				
	PCF8551ATT (I²C-bus)	PCF8551BTT (SPI-bus)		
13	T1	-	-	must be left open or connected to V_{SS}
	-	SDIO	input/output	serial data input/output
16	SDA	-	input/output	serial data line
	-	\overline{CE}	input	chip enable input, active LOW

[1] Can be configured by command, see [Table 6](#).

[2] A series resistance between V_{DD} and the pin must not exceed 1 k Ω to ensure proper functionality, see [Section 16.3](#).

8. Functional description

8.1 Registers of the PCF8551

The registers of the PCF8551 are arranged in bytes with 8 bit, addressed by an address pointer. [Table 5](#) depicts the layout.

Table 5. Registers of the PCF8551

Bits labeled as 0 must always be written with logic 0; bits labeled as - are ignored by the device.

Register name	Address	Bits								Reference
		AP[4:0]	7	6	5	4	3	2	1	
Command registers										
Software_reset	00h	SR[7:0]								Table 9
Device_ctrl	01h	0	0	0	0	FF[1:0]	OSC	COE	Table 6	
Display_ctrl_1	02h	0	0	0	BOOST	MUX[1:0]	B	DE	Table 7	
Display_ctrl_2	03h	0	0	0	0	0	BL[1:0]	INV	Table 8	
Display data registers										
COM0	04h	SEG7	SEG6	SEG5	SEG4	SEG3	SEG2	SEG1	SEG0	Table 10
	05h	SEG15	SEG14	SEG13	SEG12	SEG11	SEG10	SEG9	SEG8	
	06h	SEG23	SEG22	SEG21	SEG20	SEG19	SEG18	SEG17	SEG16	
	07h	SEG31	SEG30	SEG29	SEG28	SEG27	SEG26	SEG25	SEG24	
	08h	-	-	-	-	SEG35	SEG34	SEG33	SEG32	
COM1	09h	SEG7	SEG6	SEG5	SEG4	SEG3	SEG2	SEG1	SEG0	Table 10
	0Ah	SEG15	SEG14	SEG13	SEG12	SEG11	SEG10	SEG9	SEG8	
	0Bh	SEG23	SEG22	SEG21	SEG20	SEG19	SEG18	SEG17	SEG16	
	0Ch	SEG31	SEG30	SEG29	SEG28	SEG27	SEG26	SEG25	SEG24	
	0Dh	-	-	-	-	SEG35	SEG34	SEG33	SEG32	
COM2	0Eh	SEG7	SEG6	SEG5	SEG4	SEG3	SEG2	SEG1	SEG0	Table 10
	0Fh	SEG15	SEG14	SEG13	SEG12	SEG11	SEG10	SEG9	SEG8	
	10h	SEG23	SEG22	SEG21	SEG20	SEG19	SEG18	SEG17	SEG16	
	11h	SEG31	SEG30	SEG29	SEG28	SEG27	SEG26	SEG25	SEG24	
	12h	-	-	-	-	SEG35	SEG34	SEG33	SEG32	
COM3	13h	SEG7	SEG6	SEG5	SEG4	SEG3	SEG2	SEG1	SEG0	Table 10
	14h	SEG15	SEG14	SEG13	SEG12	SEG11	SEG10	SEG9	SEG8	
	15h	SEG23	SEG22	SEG21	SEG20	SEG19	SEG18	SEG17	SEG16	
	16h	SEG31	SEG30	SEG29	SEG28	SEG27	SEG26	SEG25	SEG24	
	17h	-	-	-	-	SEG35	SEG34	SEG33	SEG32	

For writing to the registers, send the address byte first, then write the data to the register (see [Section 11.1.4](#) and [Section 11.2.1](#)). The address byte works as an address pointer. For the succeeding registers, the address pointer is automatically incremented by 1 (see [Figure 5](#)) and all following data are written into these register addresses. After register 18h, the auto-incrementing will stop and subsequent data are ignored.

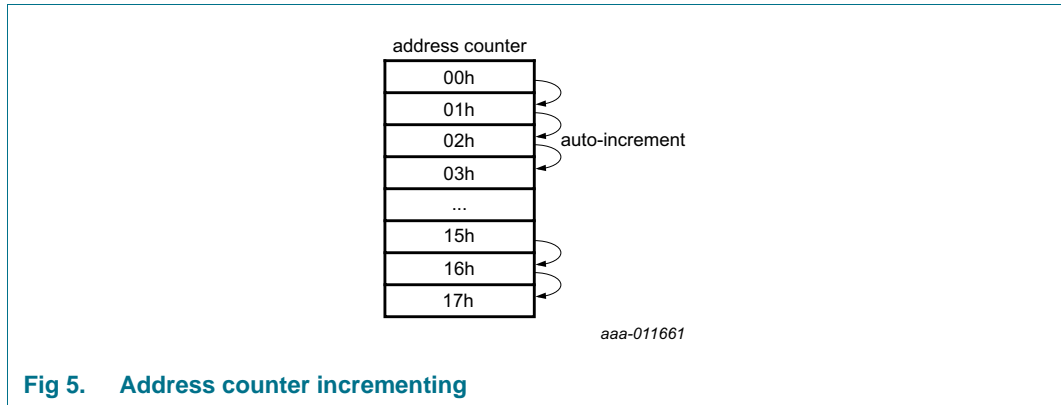

Fig 5. Address counter incrementing

8.2 Command registers of the PCF8551

8.2.1 Command: Device_ctrl

The Device_ctrl command sets the device into a defined state. It should be executed before enabling the display (see bit DE in [Table 7](#)).

Table 6. Device_ctrl - device control command register (address 01h) bit description

Bit	Symbol	Value	Description
7 to 4	-	0000	default value
3 to 2	FF[1:0]		frame frequency selection
		00	f _{fr} = 32 Hz
		01 ^[1]	f _{fr} = 64 Hz
		10	f _{fr} = 96 Hz
1	OSC		internal oscillator control
		0 ^[1]	enabled
		1	disabled
0	COE		clock output enable
		0 ^[1]	clock signal not available on pin CLK; pin CLK is in 3-state
		1	clock signal available on pin CLK

[1] Default value.

8.2.1.1 Internal oscillator and clock output

Bit OSC enables or disables the internal oscillator. When the internal oscillator is used, bit COE allows making the clock signal available on pin CLK. If this is not intended, pin CLK should be left open. The design ensures that the duty cycle of the clock output is 50 : 50 (% HIGH-level time : % LOW-level time).

In power-down mode (see [Section 8.3.1](#))

- if pin CLK is configured as an output, there is no signal on CLK
- if pin CLK is configured as an input, the signal on CLK can be removed.

In applications where an external clock has to be applied to the PCF8551, bit OSC must be set logic 1 and COE logic 0. In this case pin CLK becomes an input.

Remark: A clock signal must always be supplied to the device if the display is enabled (see bit DE in [Table 7 on page 9](#)). Removing the clock may freeze the LCD in a DC state, which is not suitable for the liquid crystal.

8.2.2 Command: Display_ctrl_1

The Display_ctrl_1 command allows configuring the basic display set-up.

Table 7. Display_ctrl_1 - display control command 1 register (address 02h) bit description

Bit	Symbol	Value	Description
7 to 5	-	000	default value
4	BOOST		large display mode support
		0 ^[1]	standard power drive scheme
		1	enhanced power drive scheme for higher display loads
3 to 2	MUX[1:0]		multiplex drive mode selection
		00 ^[1]	1:4 multiplex drive mode; COM0 to COM3 (n _{MUX} = 4)
		01	1:3 multiplex drive mode; COM0 to COM2 (n _{MUX} = 3)
		10	1:2 multiplex drive mode; COM0 and COM1 (n _{MUX} = 2)
		11	static drive mode; COM0 (n _{MUX} = 1)
1	B ^[2]		bias mode selection
		0 ^[1]	$\frac{1}{3}$ bias (a _{bias} = 2)
		1	$\frac{1}{2}$ bias (a _{bias} = 1)
0	DE		display enable^[3]
		0 ^[1]	display disabled; device is in power-down mode
		1	display enabled; device is in power-on mode

[1] Default value.

[2] Not applicable for static drive mode.

[3] See [Section 8.3.1](#).

8.2.2.1 Enhanced power drive mode

By setting the BOOST bit to logic 1, the driving capability of the display signals is increased to cope with large displays with a higher effective capacitance. Setting this bit increases the current consumption on V_{LCD}.

8.2.2.2 Multiplex drive mode

MUX[1:0] sets the multiplex driving scheme and the associated backplane drive signals, which are active. For further details, see [Section 9.2 on page 16](#).

8.2.3 Command: Display_ctrl_2

Table 8. Display_ctrl_2 - display control command 2 register (address 03h) bit description

Bit	Symbol	Value	Description
7 to 3	-	00000	default value
2 to 1	BL[1:0]		blink control
		00 ^[1]	blinking off
		01	blinking on, $f_{blink} = 0.5 \text{ Hz}$
		10	blinking on, $f_{blink} = 1 \text{ Hz}$
		11	blinking on, $f_{blink} = 2 \text{ Hz}$
0	INV		inversion mode selection
		0 ^[1]	line inversion (driving scheme A)
		1	frame inversion (driving scheme B)

[1] Default value.

8.2.3.1 Blinking

The whole display blinks at frequencies selected by the blink control bits BL[1:0], see [Table 8](#). The blink frequencies are derived from the clock frequency. During the blank-out phase of the blinking period, the display is turned off.

If an external clock with frequency $f_{clk(ext)}$ is used, the blinking frequency is determined by [Equation 1](#). For notation, see [Section 9.2](#).

$$f_{blink(eff)} = \frac{2 \times n_{MUX} \times f_{fr} \times f_{blink}}{f_{clk(ext)}} \tag{1}$$

8.2.3.2 Line inversion (driving scheme A) and frame inversion (driving scheme B)

The waveforms used to drive LCD inherently produce a DC voltage across the display cell. The PCF8551 compensates for the DC voltage by inverting the waveforms on alternate frames or alternate lines. The choice of compensation method is determined with the INV bit.

8.3 Starting and resetting the PCF8551

If the internal Power-On Reset (POR) is enabled by connecting pin PORE to V_{DD} , the chip resets automatically when V_{DD} rises above the minimum supply voltage. No further action is required.

If the internal POR is disabled by connecting pin PORE to V_{SS} , the chip must be reset by a software reset (see [Section 8.3.3](#)).

Following a reset, the register 00h has to be rewritten with 0h by the next command byte or the address pointer AP[4:0] has to be set to the required address after a new START procedure.

8.3.1 Power-down mode

After a reset, the PCF8551 remains in power-down mode. In power-down mode the oscillator is switched off and there is no output on pin CLK. The register settings remain unchanged and the bus remains active. To enable the PCF8551, bit DE (command Display_ctrl_1, see [Table 7 on page 9](#)) must be set to logic 1.

8.3.2 Power-On Reset (POR)

If pin PORE is connected to V_{DD} , the PCF8551 comprises an internal POR, which puts the device into the following starting conditions:

- All backplane and segment outputs are set to V_{SS}
- The selected drive mode is: 1:4 multiplex with $\frac{1}{3}$ bias
- Blinking is switched off
- The address pointer is cleared (set to logic 0)
- The display and the internal oscillator are disabled
- The display registers are set to logic 0

Remark: The internal POR can be disabled by connecting pin PORE to V_{SS} . In this case, the internal registers are not defined and require a software reset, see [Section 8.3.3](#).

Remark: For power-on with a slowly starting power supply, see [Section 16.1 on page 39](#).

8.3.3 Command: Software_reset

The internal registers including the display registers and the address pointer (set to logic 0) of the device are reset by the Software_reset command.

Table 9. Software_reset - software reset command register (address 00h) bit description

Bit	Symbol	Value	Description
7 to 0	SR[7:0] ^[1]		software reset
		00000000 ^[2]	no reset
		00101100	software reset

[1] Software_reset only generates a reset pulse, therefore this register always reads back as 00h.

[2] Default value.

8.4 Display data register mapping

Table 10. Register to segment and backplane mapping

Backplanes ^[1]	Segments									
	SEG0 to SEG7		SEG8 to SEG15		SEG16 to SEG23		SEG24 to SEG31		SEG32 to SEG35	
	LSB	MSB	LSB	MSB	LSB	MSB	LSB	MSB	LSB	MSB
1:4 multiplex drive mode										
COM0	content of 04h		content of 05h		content of 06h		content of 07h		content of 08h	
COM1	content of 09h		content of 0Ah		content of 0Bh		content of 0Ch		content of 0Dh	
COM2	content of 0Eh		content of 0Fh		content of 10h		content of 11h		content of 12h	
COM3	content of 13h		content of 14h		content of 15h		content of 16h		content of 17h	
1:3 multiplex drive mode										
COM0	content of 04h		content of 05h		content of 06h		content of 07h		content of 08h	
COM1	content of 09h		content of 0Ah		content of 0Bh		content of 0Ch		content of 0Dh	
COM2	content of 0Eh		content of 0Fh		content of 10h		content of 11h		content of 12h	
1:2 multiplex drive mode										
COM0	content of 04h		content of 05h		content of 06h		content of 07h		content of 08h	
COM1	content of 09h		content of 0Ah		content of 0Bh		content of 0Ch		content of 0Dh	
static drive mode										
COM0	content of 04h		content of 05h		content of 06h		content of 07h		content of 08h	

[1] See also [Section 9.3.1 on page 24](#)

The example in [Table 10](#) and [Figure 6](#) illustrates the segment and backplane mapping of the display in relation to the display RAM.

For example, in 1:4 multiplex drive mode, the backplanes are served by signals COM0 to COM3 and the segments are driven by signals SEG0 to SEG35. Contents of addresses 04h to 08h are allocated to the first row (COM0) starting with the LSB driving the leftmost element and moving forward to the right with increasing bit position. If a bit is logic 0, the element is off, if it is logic 1 the element is turned on. All register content is LSB to MSB left to right. Addresses 09h to 0Dh serve COM1 signals, addresses 0Eh to 12h serve COM2 signals, and addresses 13h to 17h serve COM3 signals.

For displays with fewer segments/elements, the unused bits are ignored.

All information provided in this document is subject to legal disclaimers. © NXP Semiconductors N.V. 2015. All rights reserved. PCF8551

Fig. 6. Display RAM organization bitmap for MUX 1:4

	COM3	COM2	COM1	COM0	
SEG1	D120	D80	D40	D0	SEG0
SEG3					SEG2
SEG5					SEG4
SEG7	D127	D87	D47	D7	SEG6
SEG9	D128	D88	D48	D8	SEG8
SEG11					SEG10
SEG13					SEG12
SEG15	D135	D95	D55	D15	SEG14
SEG17	D136	D96	D56	D16	SEG16
SEG19					SEG18
SEG21					SEG20
SEG23	D143	D103	D63	D23	SEG22
SEG25	D144	D104	D64	D24	SEG24
SEG27					SEG26
SEG29					SEG28
SEG31	D151	D111	D71	D31	SEG30
SEG33	D152	D112	D72	D32	SEG32
SEG35					SEG34
	D156	D116	D76	D36	discarded
	D157	D117	D77	D37	
	D158	D118	D78	D38	
	D159	D119	D79	D39	

aaa-014858

Display

RAM

9. Possible display configurations

The possible display configurations of the PCF8551 depend on the number of active backplane outputs required. A selection of display configurations is shown in [Table 11](#). All of these configurations can be implemented in the typical systems shown in [Figure 8](#) or [Figure 9](#).

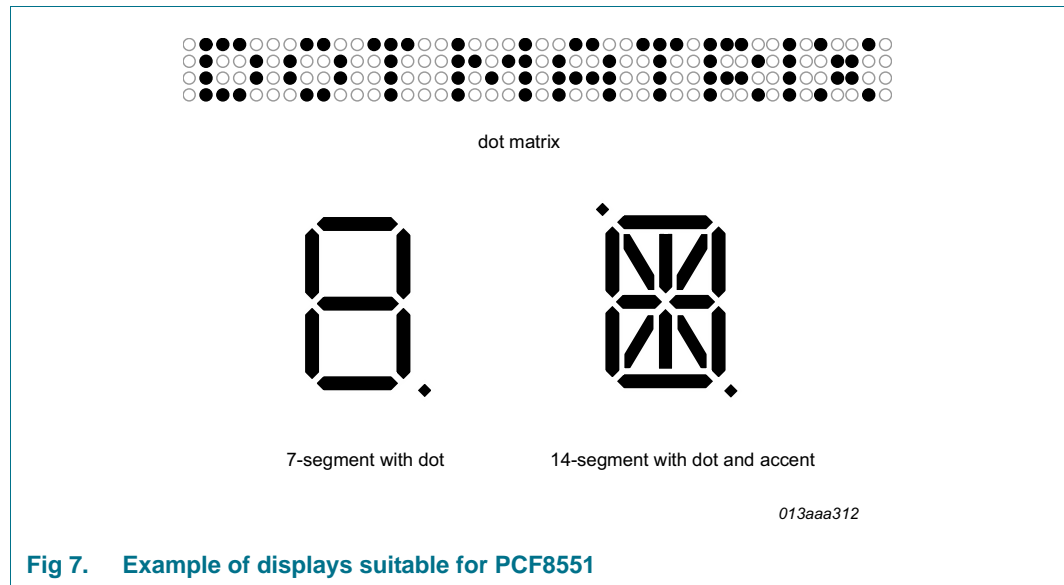

Fig 7. Example of displays suitable for PCF8551

Table 11. Selection of possible display configurations

Number of Backplanes	Icons	Digits/Characters		Dot matrix: segments/elements
		7-segment ^[1]	14-segment ^[2]	
4	144	18	9	144 dots (4 × 36)
3	108	13	6	108 dots (3 × 36)
2	72	9	4	72 dots (2 × 36)
1	36	4	2	36 dots (1 × 36)

[1] 7 segment display has 8 segments/elements including the decimal point.

[2] 14 segment display has 16 segments/elements including decimal point and accent dot.

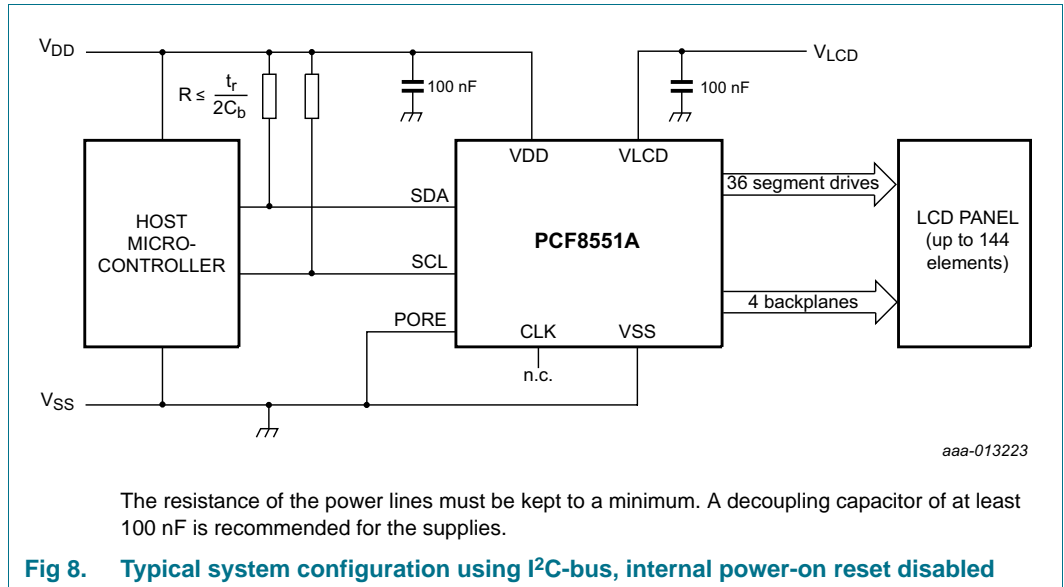

The host microcontroller manages the 2-line I²C-bus communication channel with the PCF8551A. The internal oscillator is used and the internal POR is disabled in the example. The appropriate biasing voltages for the multiplexed LCD waveforms are generated internally. The only other connections required to complete the system are the power supplies (V_{DD}, V_{SS}, and V_{LCD}) and the LCD panel chosen for the application.

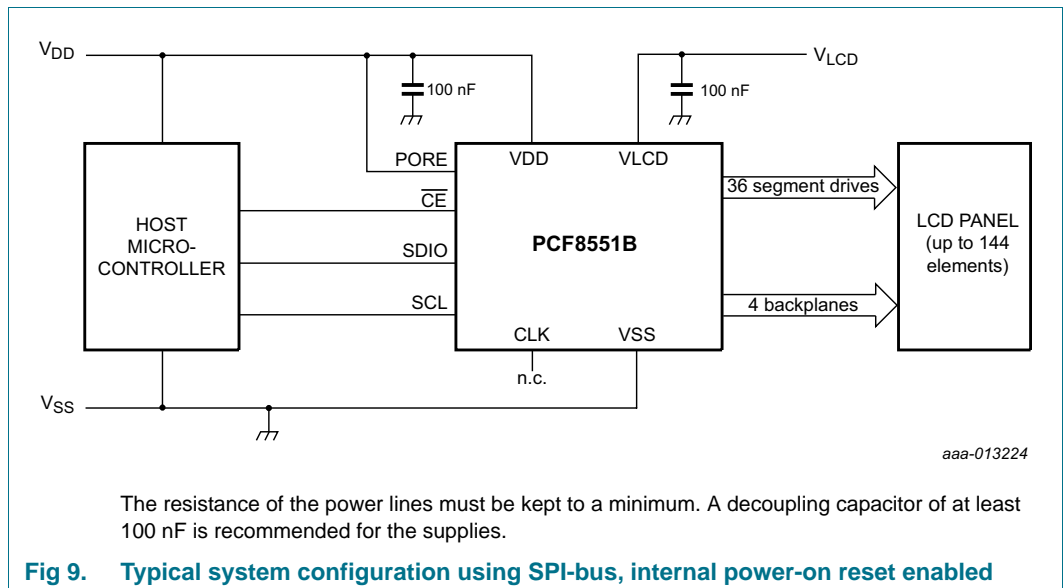

The host microcontroller manages the 3-line SPI-bus communication channel with the PCF8551B. The internal oscillator is enabled. The appropriate biasing voltages for the multiplexed LCD waveforms are generated internally. The only other connections required to complete the system are the power supplies (V_{DD}, V_{SS}, and V_{LCD}) and the LCD panel chosen for the application.

9.1 LCD bias generator

Fractional LCD biasing voltages are obtained from an internal voltage divider of three impedances connected between V_{LCD} and V_{SS} . These intermediate levels are tapped off at positions of $\frac{1}{3}$ and $\frac{2}{3}$, or $\frac{1}{2}$, depending on the bias mode chosen. To keep current consumption to a minimum, on-chip low-power buffers provide these levels to the display.

9.2 LCD voltage selector

The LCD voltage selector coordinates the multiplexing of the LCD in accordance with the selected LCD drive configuration. The operation of the voltage selector is controlled by the Display_ctrl_1 command (see [Table 7](#)). The biasing configurations that apply to the preferred modes of operation, together with the biasing characteristics as functions of V_{LCD} and the resulting discrimination ratios (D) are given in [Table 12](#).

Table 12. Biasing characteristics

LCD drive mode	Number of:		LCD bias configuration	$\frac{V_{off(RMS)}}{V_{LCD}}$	$\frac{V_{on(RMS)}}{V_{LCD}}$	$D = \frac{V_{on(RMS)}}{V_{off(RMS)}}$
	Backplanes	Levels				
static	1	2	static	0	1	∞
1:2 multiplex	2	3	$\frac{1}{2}$	0.354	0.791	2.236
1:2 multiplex	2	4	$\frac{1}{3}$	0.333	0.745	2.236
1:3 multiplex	3	4	$\frac{1}{3}$	0.333	0.638	1.915
1:4 multiplex	4	4	$\frac{1}{3}$	0.333	0.577	1.732

A practical value for V_{LCD} is determined by equating $V_{off(RMS)}$ with a defined LCD threshold voltage ($V_{th(off)}$), typically when the LCD exhibits approximately 10 % contrast. In the static drive mode, a suitable choice is $V_{LCD} > 3V_{th(off)}$.

Multiplex drive modes of 1:3 and 1:4 with $\frac{1}{2}$ bias are possible but the discrimination and hence the contrast ratios are smaller.

Bias is calculated with [Equation 2](#)

$$\frac{1}{1 + a_{bias}} \tag{2}$$

The values for a_{bias} are:

$$a_{bias} = 1 \text{ for } \frac{1}{2} \text{ bias}$$

$$a_{bias} = 2 \text{ for } \frac{1}{3} \text{ bias}$$

The RMS on-state voltage ($V_{on(RMS)}$) for the LCD is calculated with [Equation 3](#):

$$V_{on(RMS)} = V_{LCD} \sqrt{\frac{a_{bias}^2 + 2a_{bias} + n_{MUX}}{n_{MUX} \times (1 + a_{bias})^2}} \tag{3}$$

where the values for n are

- $n_{MUX} = 1$ for static drive mode
- $n_{MUX} = 2$ for 1:2 multiplex drive mode
- $n_{MUX} = 3$ for 1:3 multiplex drive mode
- $n_{MUX} = 4$ for 1:4 multiplex drive mode

The RMS off-state voltage ($V_{off(RMS)}$) for the LCD is calculated with [Equation 4](#):

$$V_{off(RMS)} = V_{LCD} \sqrt{\frac{a_{bias}^2 - 2a_{bias} + n_{MUX}}{n_{MUX} \times (1 + a_{bias})^2}} \tag{4}$$

Discrimination is a term which is defined as the ratio of the on and off RMS voltages ($V_{on(RMS)}$ to $V_{off(RMS)}$) across a segment. It can be thought of as a measurement of contrast. Discrimination is determined from [Equation 5](#):

$$D = \frac{V_{on(RMS)}}{V_{off(RMS)}} = \sqrt{\frac{a_{bias}^2 + 2a_{bias} + n_{MUX}}{a_{bias}^2 - 2a_{bias} + n_{MUX}}} \tag{5}$$

Using [Equation 5](#), the discrimination for an LCD drive mode of 1:3 multiplex with $\frac{1}{2}$ bias is $\sqrt{3} = 1.732$ and the discrimination for an LCD drive mode of 1:4 multiplex with $\frac{1}{2}$ bias is $\frac{\sqrt{21}}{3} = 1.528$.

The advantage of these LCD drive modes is a reduction of the LCD full scale voltage V_{LCD} as follows:

- 1:3 multiplex ($\frac{1}{2}$ bias): $V_{LCD} = \sqrt{6} \times V_{off(RMS)} = 2.449V_{off(RMS)}$
- 1:4 multiplex ($\frac{1}{2}$ bias): $V_{LCD} = \left[\frac{4 \times \sqrt{3}}{3} \right] = 2.309V_{off(RMS)}$

These compare with $V_{LCD} = 3V_{off(RMS)}$ when $\frac{1}{3}$ bias is used.

V_{LCD} is sometimes referred as the LCD operating voltage.

9.2.1 Electro-optical performance

Suitable values for $V_{on(RMS)}$ and $V_{off(RMS)}$ are dependent on the LCD liquid used. The RMS voltage, at which a pixel is switched on or off, determine the transmissibility of the pixel.

For any given liquid, there are two threshold values defined. One point is at 10 % relative transmission (at $V_{th(off)}$) and the other at 90 % relative transmission (at $V_{th(on)}$), see [Figure 10](#). For a good contrast performance, the following rules should be followed:

$$V_{on(RMS)} \geq V_{th(on)} \tag{6}$$

$$V_{off(RMS)} \leq V_{th(off)} \tag{7}$$

$V_{on(RMS)}$ (see [Equation 3](#)) and $V_{off(RMS)}$ (see [Equation 5](#)) are properties of the display driver and are affected by the selection of a_{bias} , n_{MUX} , and the V_{LCD} voltage.

$V_{th(off)}$ and $V_{th(on)}$ are properties of the LCD liquid and can be provided by the module manufacturer. $V_{th(off)}$ is sometimes named V_{th} . $V_{th(on)}$ is sometimes named saturation voltage V_{sat} .

It is important to match the module properties to those of the driver in order to achieve optimum performance.

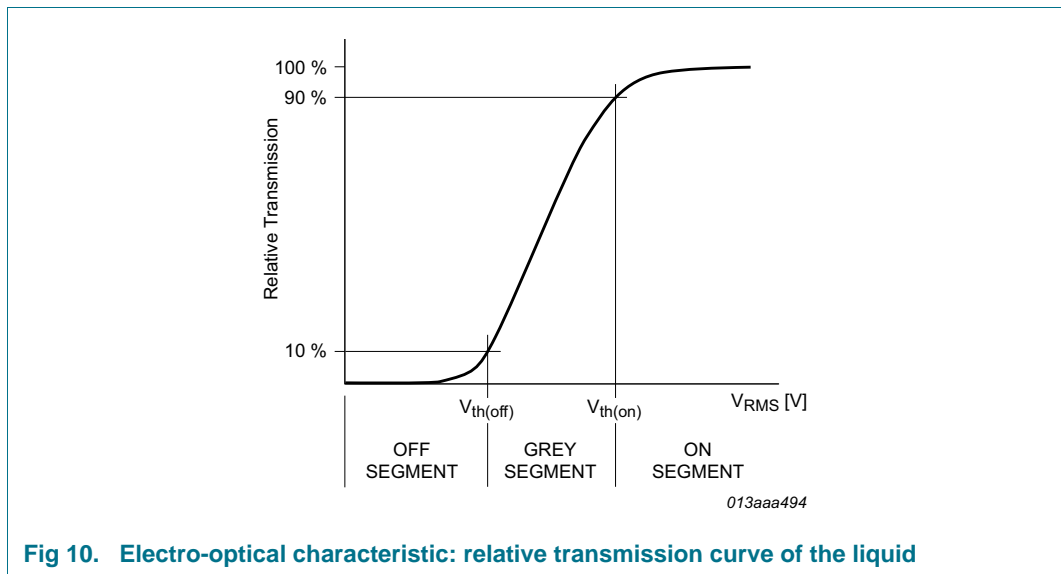

Fig 10. Electro-optical characteristic: relative transmission curve of the liquid

9.2.2 LCD drive mode waveforms

9.2.2.1 Static drive mode

The static LCD drive mode is used when a single backplane is provided in the LCD. The backplane (COMn) and segment (SEGN) drive waveforms for this mode are shown in [Figure 11](#).

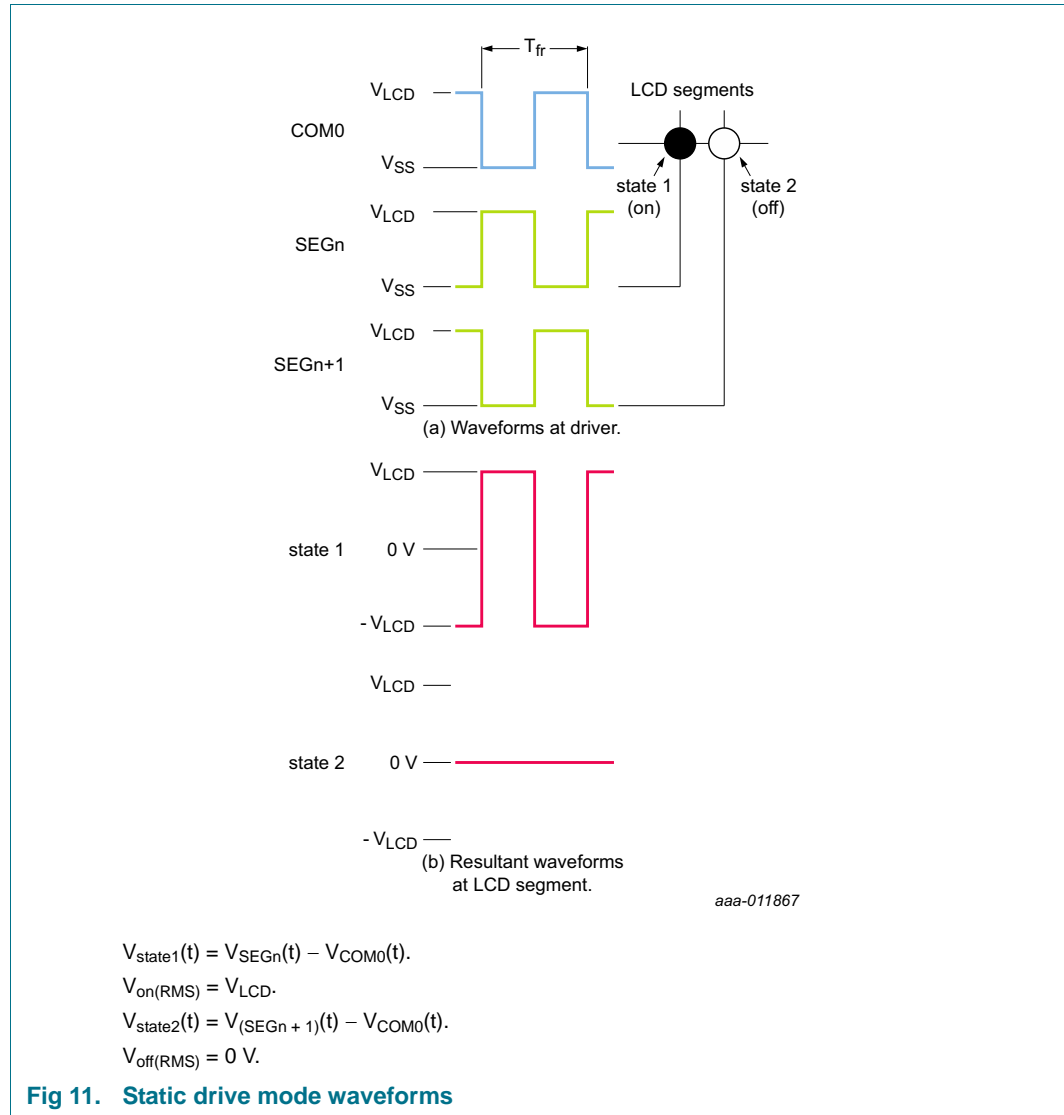
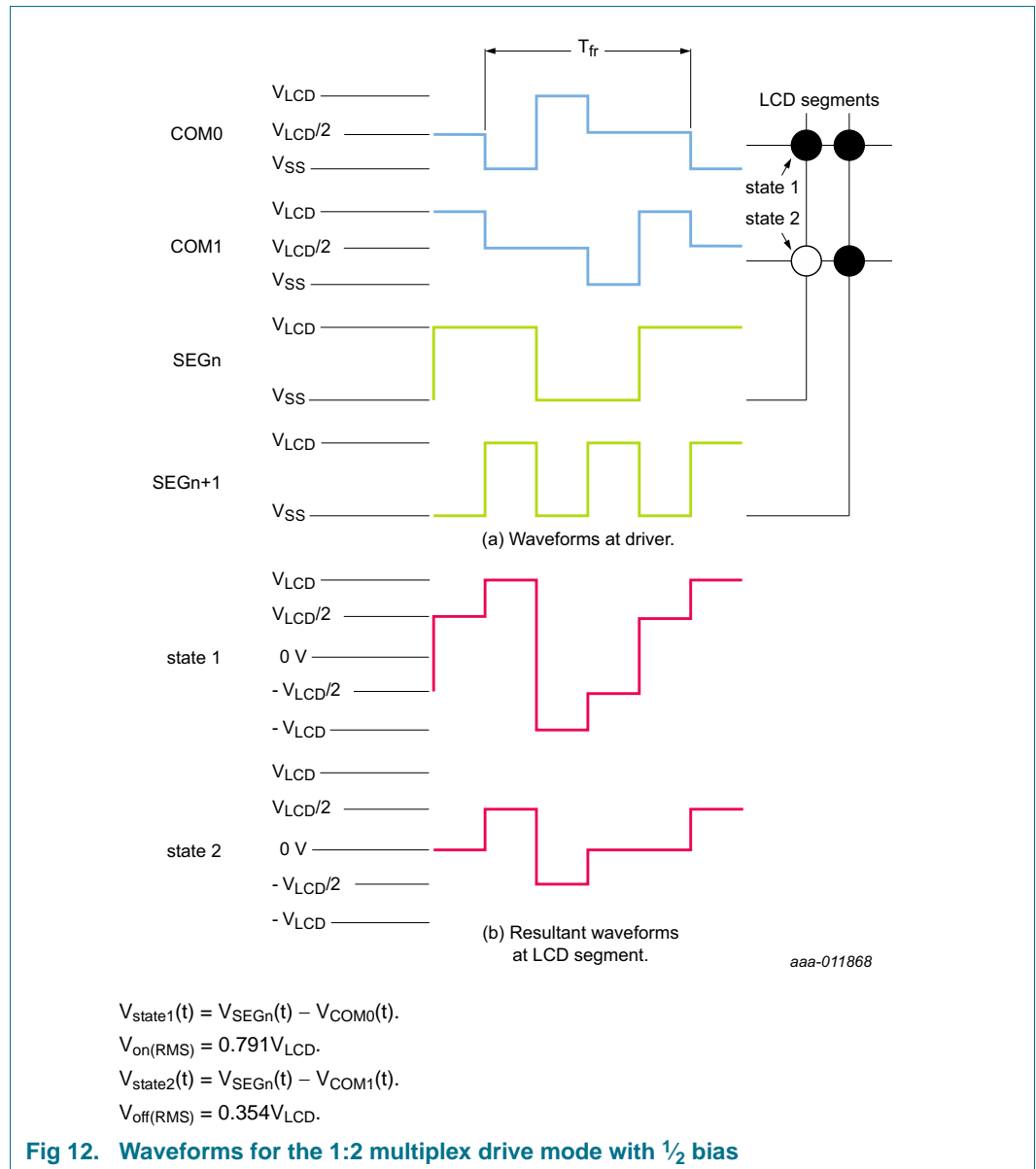
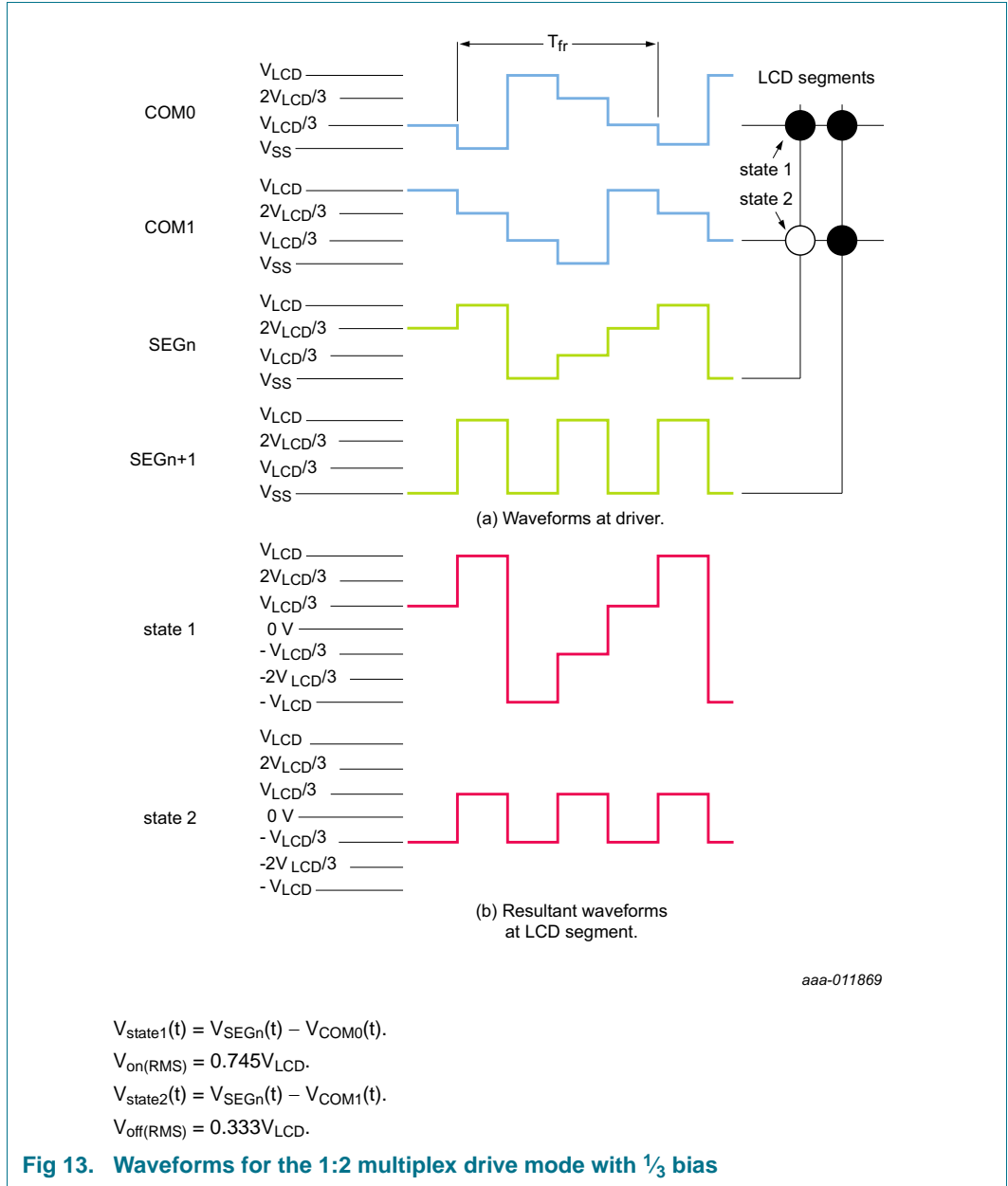

Fig 11. Static drive mode waveforms

9.2.2.2 1:2 Multiplex drive mode

When two backplanes are provided in the LCD, the 1:2 multiplex mode applies. The PCF8551 allows the use of 1/2 bias or 1/3 bias in this mode as shown in Figure 12 and Figure 13.





9.2.2.3 1:3 Multiplex drive mode

When three backplanes are provided in the LCD, the 1:3 multiplex drive mode applies, as shown in Figure 14.

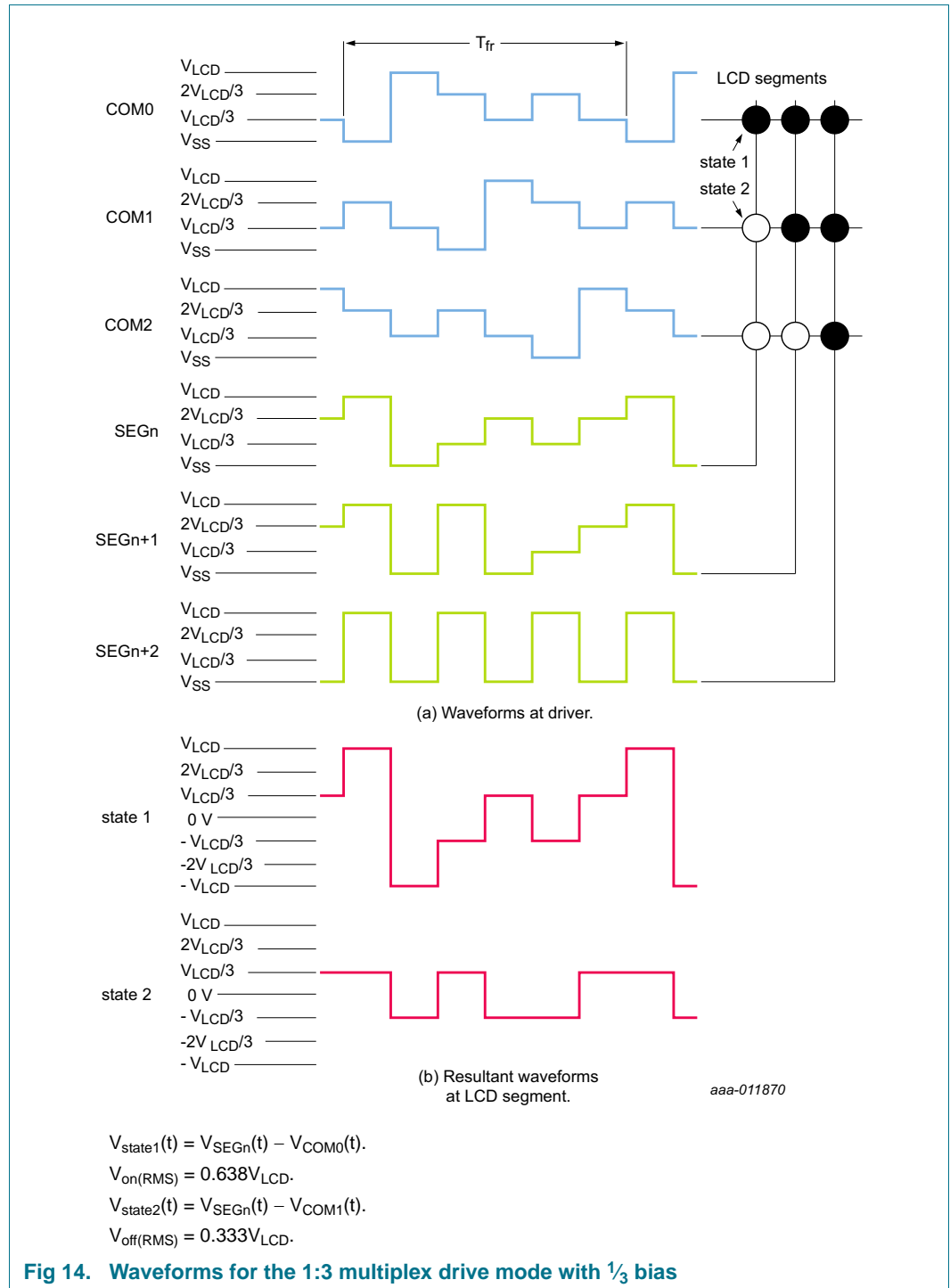

9.2.2.4 1:4 Multiplex drive mode

When four backplanes are provided in the LCD, the 1:4 multiplex drive mode applies as shown in Figure 15.

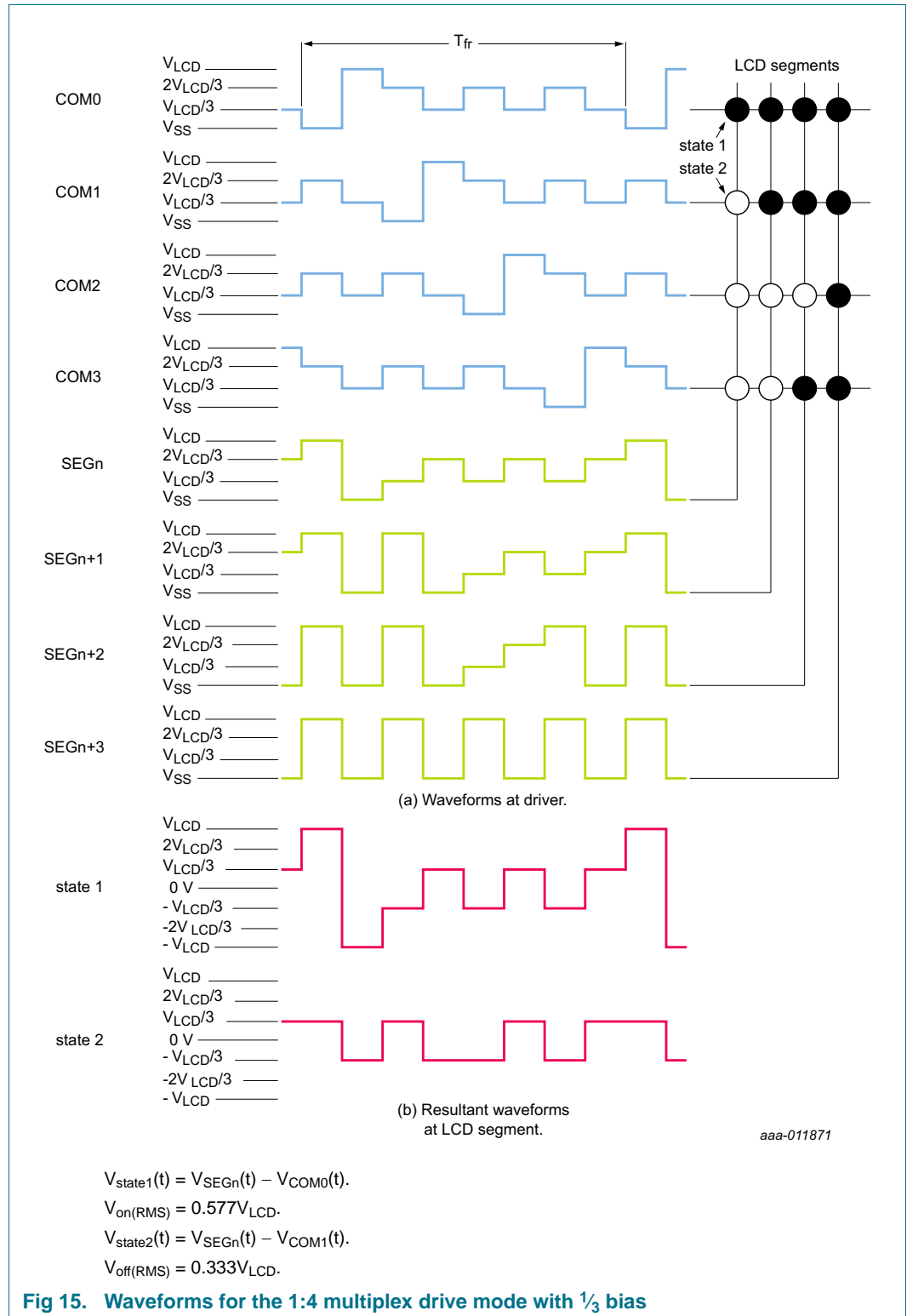

9.3 Backplane and segment outputs

9.3.1 Backplane outputs

The LCD drive section includes four backplane outputs COM0 to COM3, which must be directly connected to the LCD. The backplane output signals are generated in accordance with the selected LCD drive mode. If less than four backplane outputs are required, the unused outputs can be left open-circuit.

- In 1:3 multiplex drive mode, COM3 carries the same signal as COM1, therefore these two outputs can be tied together to give enhanced drive capabilities
- In 1:2 multiplex drive mode, COM0 and COM2, respectively, COM1 and COM3 all carry the same signals and may also be paired to increase the drive capabilities
- In static drive mode, the same signal is carried by all four backplane outputs and they can be connected in parallel for very high drive requirements

9.3.2 Segment outputs

The LCD drive section includes 36 segment outputs SEG0 to SEG35, which must be directly connected to the LCD. The segment output signals are generated in accordance with the multiplexed backplane signals and with data residing in the display registers. When less than 36 segment outputs are required, the unused segment outputs must be left open-circuit.

10. Power Sequencing

10.1 Power-on

To avoid unwanted artifacts on the display, V_{LCD} must never be asserted before V_{DD} , it is permitted to assert V_{DD} and V_{LCD} at the same time.

10.2 Power-off

Before turning the power to the device off, the display must be disabled by setting bit DE to logic 0. To avoid unwanted artifacts on the display, V_{LCD} must never be connected, while V_{DD} is switched off. It is permitted to switch off V_{DD} and V_{LCD} simultaneously.

10.3 Power sequences

[Figure 16](#) depicts the recommended power-up and power-off sequence.

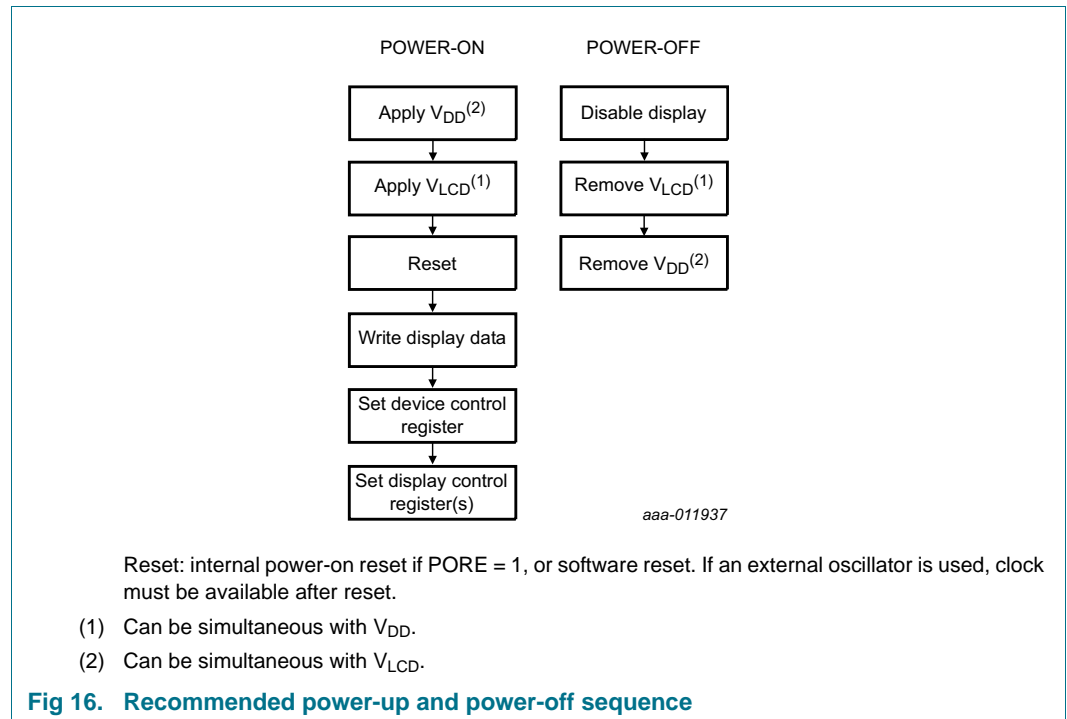

11. Bus interfaces

11.1 I²C-bus interface of the PCF8551A

The I²C-bus is for bidirectional, two-line communication between different ICs. The two lines are a Serial Data line (SDA) and a Serial Clock line (SCL). Both lines must be connected to a positive supply via a pull-up resistor. Data transfer may be initiated only when the bus is not busy. Both data and clock lines remain HIGH when the bus is not busy. The PCF8551A acts as a slave receiver when being written to and as a slave transmitter when being read from.

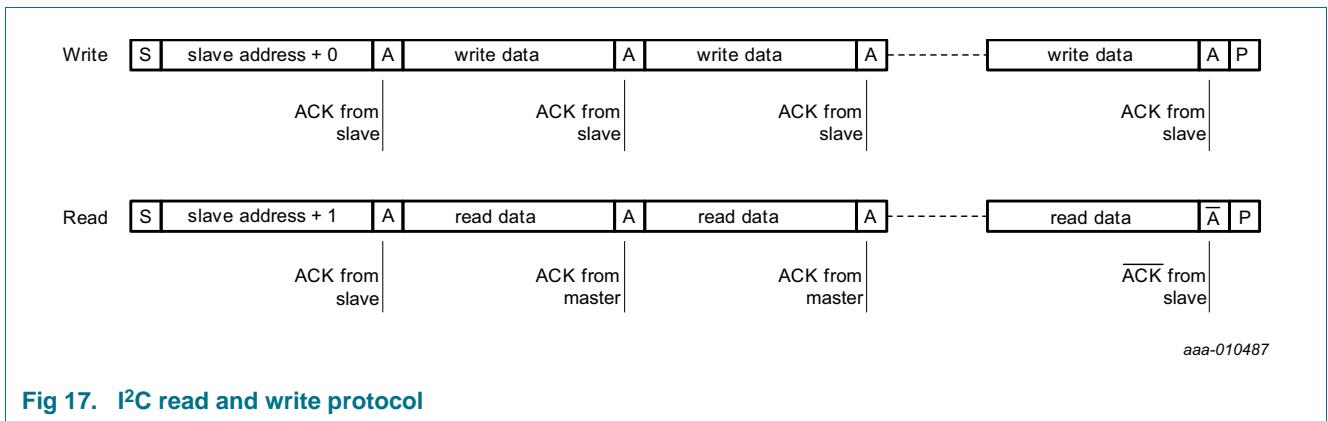

Fig 17. I²C read and write protocol

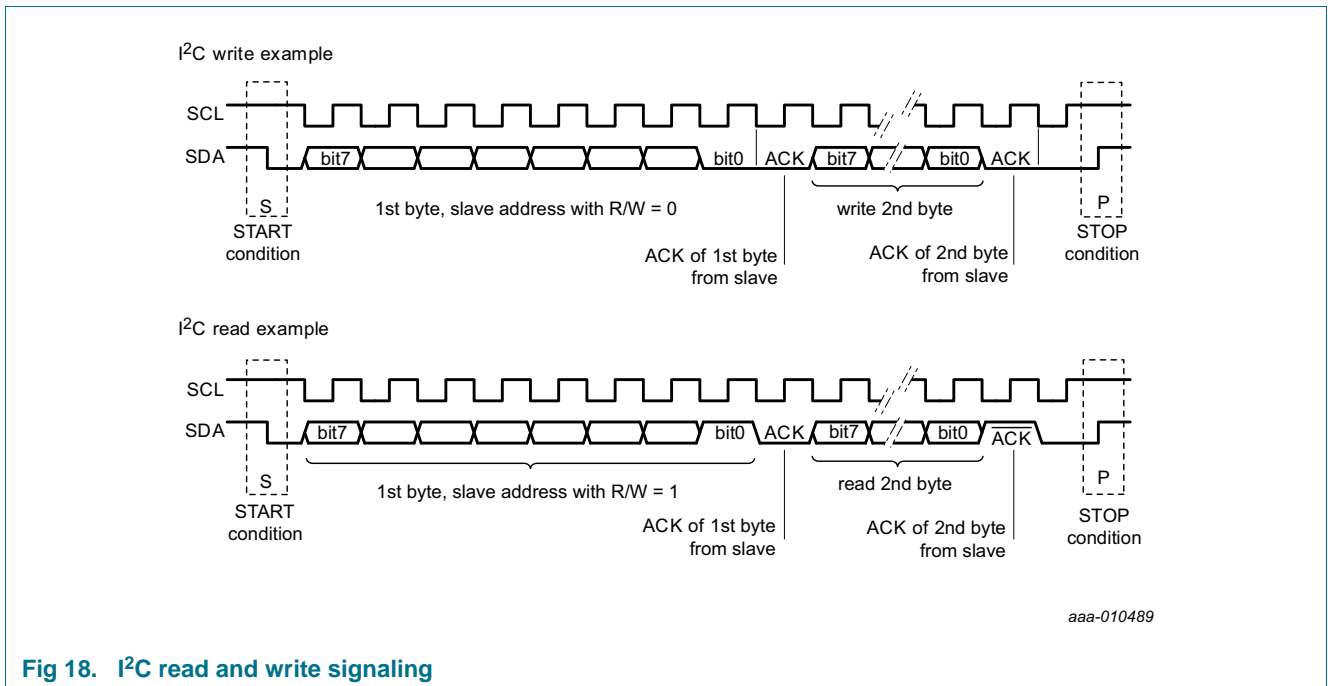

Fig 18. I²C read and write signaling

11.1.1 Bit transfer

One data bit is transferred during each clock pulse. The data on the SDA line must remain stable during the HIGH period of the clock pulse, as changes in the data line at this time are interpreted as STOP or START conditions.

11.1.2 START and STOP conditions

A HIGH-to-LOW transition of the data line while the clock is HIGH is defined as the START condition - S.

A LOW-to-HIGH transition of the data line while the clock is HIGH is defined as the STOP condition - P (see [Figure 18](#)).

11.1.3 Acknowledge

Each byte of 8 bits is followed by an acknowledge cycle. An acknowledge is defined as logic 0. A not-acknowledge is defined as logic 1.

When written to, the slave will generate an acknowledge after the reception of each byte. After the acknowledge, another byte may be transmitted. It is also possible to send a STOP or START condition.

When read from, the master receiver must generate an acknowledge after the reception of each byte. When the master receiver no longer requires bytes to be transmitted, it must generate a not-acknowledge. After the not-acknowledge, either a STOP or START condition must be sent.

Remark: The PCF8551A omits the not-acknowledge. After the last byte read, the end of transmission is indicated by a STOP or START condition from the master.

A detailed description of the I²C-bus specification is given in [Ref. 12 "UM10204"](#).

11.1.4 I²C interface protocol

The PCF8551A uses the I²C interface for data transfer. Interpretation of the data is determined by the interface protocol.

11.1.4.1 Write protocol

After the I²C slave address is transmitted, the PCF8551A requires that the register address pointer is defined. It can take the value 00h to 17h. Values outside of that range will result in the transfer being ignored, however the slave will still respond with acknowledge pulses.

After the register address has been transmitted, write data is transmitted. The minimum number of data write bytes is 0 and the maximum number is unlimited. After each write, the address pointer increments by one. After address 17h, the address pointer stops incrementing at 18h.

- I²C START condition
- I²C slave address + write
- start register pointer
- write data
- write data
- :
- write data
- I²C STOP condition; an I²C RE-START condition is also possible.

11.1.4.2 Read protocol

When reading the PCF8551A, reading starts at the current position of the address pointer. The address pointer for read data should first be defined by a write sequence.

- I²C START condition
- I²C slave address + write
- start address pointer
- I²C STOP condition; an I²C RE-START condition is also possible.

After setting the address pointer, a read can be executed. After the I²C slave address is transmitted, the PCF8551A will immediately output read data. After each read, the address pointer increments by one. After address 17h, the address pointer stops incrementing at 18h.

- I²C START condition
- I²C slave address + read
- read data (master sends acknowledge bit)
- read data (master sends acknowledge bit)
- :

11.1.4.3 I²C-bus slave address

Device selection depends on the I²C-bus slave address (see [Table 13](#)).

Table 13. I²C slave address byte

	Slave address							
Bit	7 MSB	6	5	4	3	2	1	0 LSB
	0	1	1	1	0	0	0	R/ \overline{W}

The least significant bit of the slave address byte is bit R/ \overline{W} (see [Table 14](#)).

Table 14. R/ \overline{W} -bit description

R/ \overline{W}	Description
0	write data
1	read data

11.2 SPI-bus interface of the PCF8551B

Data transfer to the device is made via a 3-line SPI-bus (see [Table 15](#)). There is no dedicated output data line. The SPI-bus is initialized whenever the chip enable line pin \overline{CE} is pulled down.

Table 15. Serial interface

Symbol	Function	Description
\overline{CE}	chip enable input ^[1] ; active LOW	when HIGH, the interface is reset
SCL	serial clock input	input may be higher than V_{DD}
SDIO	serial data input/output	input data are sampled on the rising edge of SCL, output data are valid after the falling edge of SCL

[1] The chip enable must not be wired permanently LOW.

11.2.1 Data transmission

The chip enable signal is used to identify the transmitted data. Each data transfer is a byte with the Most Significant Bit (MSB) sent first.

The transmission is controlled by the active LOW chip enable signal \overline{CE} . The first byte transmitted is the register address comprising of the address pointer and the R/W bit.

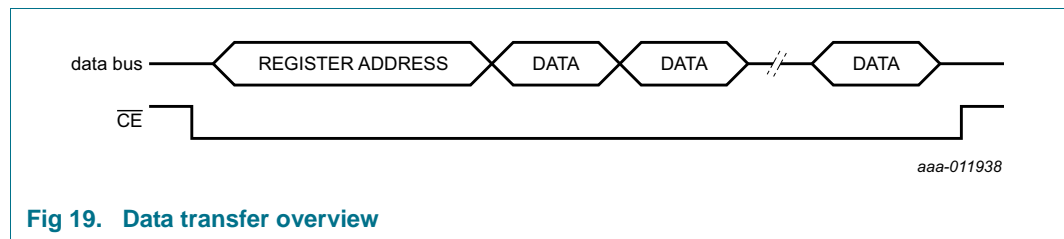

Fig 19. Data transfer overview

Table 16. Address byte definition

Bit	Symbol	Value	Description
7	R/W		data read or write selection
		0	write data
		1	read data
6 to 5	-	00	default value
4 to 0	AP[4:0]		pointer to register start address
		00h to 17h	valid range; other addresses are ignored

After the register address byte, the register contents follows with the address pointer being auto-incremented after every eighth bit sent (see [Section 8.1 on page 7](#)).

11.2.1.1 Write protocol

After the \overline{CE} is set LOW, the PCF8551B requires that R/W and the register address pointer is defined. It can take the value 00h to 17h. Values outside of that range result in the transfer being ignored.

After the register address has been transmitted, write data is transmitted. The minimum number of data write bytes is 0 and the maximum number is unlimited. After each write, the address pointer increments by one. After address 17h, the address pointer stops incrementing at 18h.

- \overline{CE} set LOW
- $R/\overline{W} = 0$ and register address
- write data
- write data
- :
- write data
- \overline{CE} set HIGH

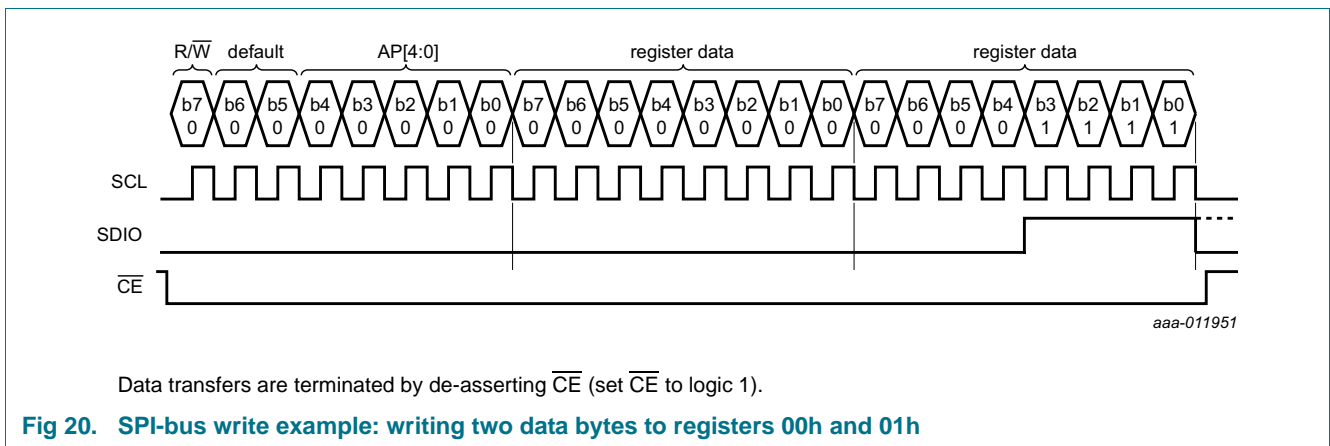

11.2.1.2 Read protocol

When reading the PCF8551B, reading starts at the defined position of the address pointer. After setting the address pointer, the read can be executed. After each read, the address pointer increments by one. After address 17h, the address pointer stops incrementing at 18h.

- \overline{CE} set LOW
- $R/\overline{W} = 1$ and register address
- read data
- read data
- :
- \overline{CE} set HIGH

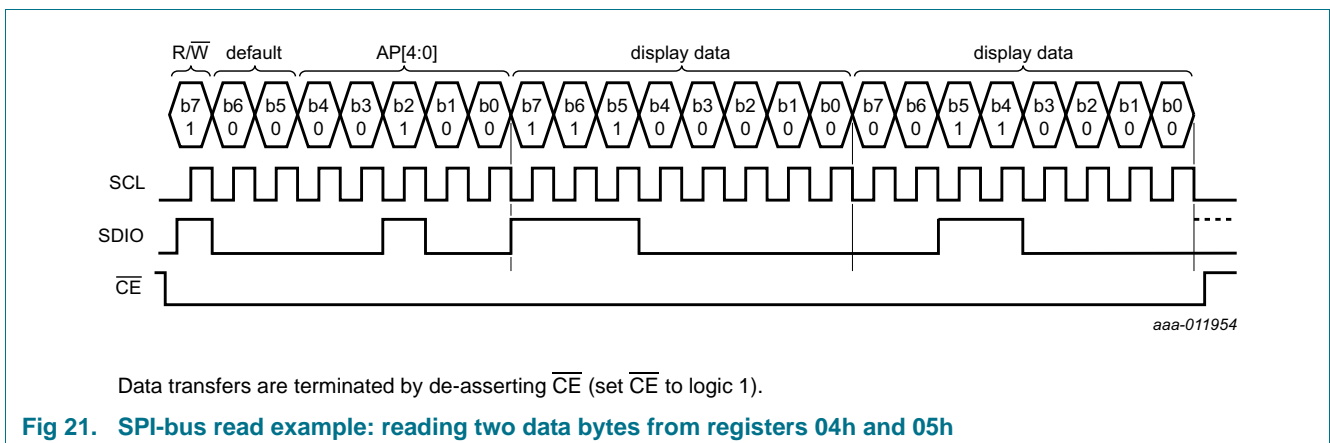

11.3 EMC detection

The PCF8551 is ruggedized against EMC susceptibility; however it is not possible to cover all cases. To detect if a severe EMC event has occurred, it is possible to check the responsiveness of the device by reading its registers.

12. Internal circuitry

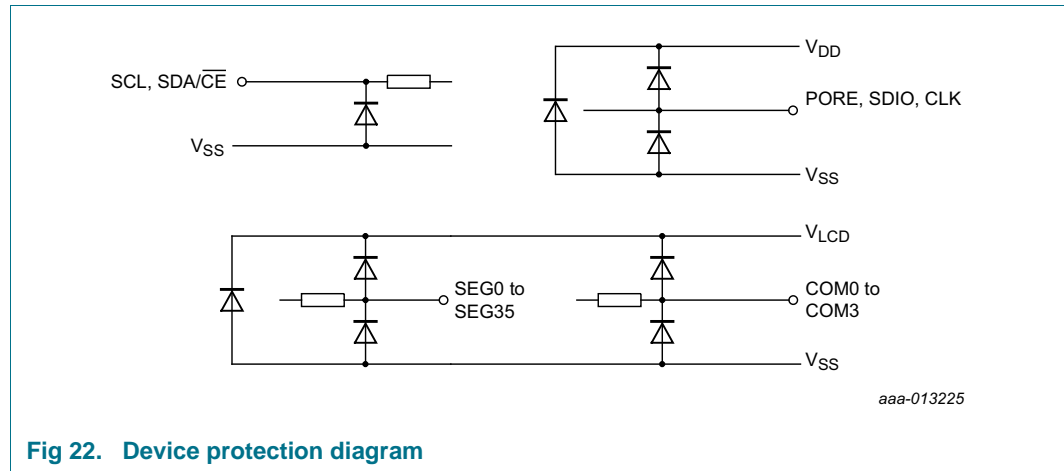

Fig 22. Device protection diagram

13. Safety notes

CAUTION



This device is sensitive to ElectroStatic Discharge (ESD). Observe precautions for handling electrostatic sensitive devices. Such precautions are described in the *ANSI/ESD S20.20*, *IEC/ST 61340-5*, *JESD625-A* or equivalent standards.

CAUTION



Static voltages across the liquid crystal display can build up when the LCD supply voltage (V_{LCD}) is on while the IC supply voltage (V_{DD}) is off, or vice versa. This may cause unwanted display artifacts. To avoid such artifacts, V_{LCD} and V_{DD} must be applied or removed together.

14. Limiting values

Table 17. Limiting values

In accordance with the Absolute Maximum Rating System (IEC 60134).

Symbol	Parameter	Conditions	Min	Max	Unit
V _{DD}	supply voltage		-0.5	+6.5	V
V _{LCD}	LCD supply voltage		-0.5	+6.5	V
V _I	input voltage		-0.5	+6.5	V
V _O	output voltage		-0.5	+6.5	V
I _I	input current		-10	+10	mA
I _O	output current		-10	+10	mA
I _{DD}	supply current		-50	+50	mA
I _{DD(LCD)}	LCD supply current		-50	+50	mA
I _{SS}	ground supply current		-50	+50	mA
P _{tot}	total power dissipation		-	100	mW
P _o	output power		-	100	mW
V _{ESD}	electrostatic discharge voltage	HBM [1]			
		on pins SCL, SDA, \overline{CE}	-	±2000	V
		on all other pins	-	±5000	V
		CDM [2]	-	±500	V
I _{lu}	latch-up current	[3]	-	200	mA
T _{stg}	storage temperature	[4]	-55	+150	°C
T _{amb}	ambient temperature	operating device	-40	+85	°C

[1] Pass level; Human Body Model (HBM), according to [Ref. 7 "JESD22-A114"](#).

[2] Pass level; Charged-Device Model (CDM), according to [Ref. 8 "JESD22-C101"](#).

[3] Pass level; latch-up testing according to [Ref. 9 "JESD78"](#) at maximum ambient temperature (T_{amb(max)}).

[4] According to the store and transport requirements (see [Ref. 13 "UM10569"](#)) the devices have to be stored at a temperature of +8 °C to +45 °C and a humidity of 25 % to 75 %.

15. Characteristics

Table 18. Electrical characteristics

$V_{DD} = 1.8\text{ V to }5.5\text{ V}$; $V_{SS} = 0\text{ V}$; $V_{LCD} = 1.8\text{ V to }5.5\text{ V}$; $T_{amb} = -40\text{ °C to }+85\text{ °C}$; unless otherwise specified.

Symbol	Parameter	Conditions	Min	Typ	Max	Unit
Supplies						
V_{DD}	supply voltage		1.8	-	5.5	V
V_{LCD}	LCD supply voltage		1.8	-	5.5	V
I_{DD}	supply current	$f_{fr} = 64\text{ Hz}$; no bus activity				
		$V_{DD} = 3.3\text{ V}$; $T_{amb} = 25\text{ °C}$	-	0.6	-	μA
		$V_{DD} = 5.5\text{ V}$; $T_{amb} = 85\text{ °C}$	-	1.2	2.7	μA
$I_{DD(LCD)}$	LCD supply current	$f_{fr} = 64\text{ Hz}$; no bus activity [1]				
		$V_{LCD} = 5.5\text{ V}$; $T_{amb} = 85\text{ °C}$; BOOST = 0; no display load	-	3.2	4.5	μA
		$V_{LCD} = 3.3\text{ V}$; $T_{amb} = 25\text{ °C}$				
		BOOST = 0; no display load	-	2.5	-	μA
		BOOST = 0; display enabled; display load $C_L = 1.4\text{ nF}$	-	4.5	-	μA
		BOOST = 1; display enabled; display load $C_L = 1.4\text{ nF}$	-	5.5	-	μA
V_{IL}	LOW-level input voltage		V_{SS}	-	$0.3V_{DD}$	V
V_{IH}	HIGH-level input voltage	[2]	$0.7V_{DD}$	-	V_{DD}	V
I_{OL}	LOW-level output current	output sink current; $V_{OL} = 0.4\text{ V}$; $V_{DD} = 5\text{ V}$				
		on pin CLK	2	-	-	mA
		on pin SDIO	2	-	-	mA
		on pin SDA	3	-	-	mA
I_{OH}	HIGH-level output current	output source current; on pins SDIO, CLK; $V_{OH} = 4.6\text{ V}$; $V_{DD} = 5\text{ V}$	2	-	-	mA
I_L	leakage current	any input pin except for $\overline{\text{RST}}$	-	0	-	nA
		after ESD event	-500	-	+500	nA
$R_{pu(RST_n)}$	pull-up resistance on pin RST_N		-	100	-	k Ω
LCD outputs (pins SEG0 to SEG17 and COM0 to COM3)						
ΔV_o	output voltage variation	$V_{LCD} = 5\text{ V}$	-100	-	+100	mV
R_o	output resistance	$V_{LCD} = 5\text{ V}$ [3]	-	1.5	3	k Ω

[1] For typical values, also see [Figure 23](#) to [Figure 25](#).

[2] I²C pins SCL and SDA have no diode to V_{DD} and may be driven up to 5.5 V.

[3] Outputs measured one at a time.

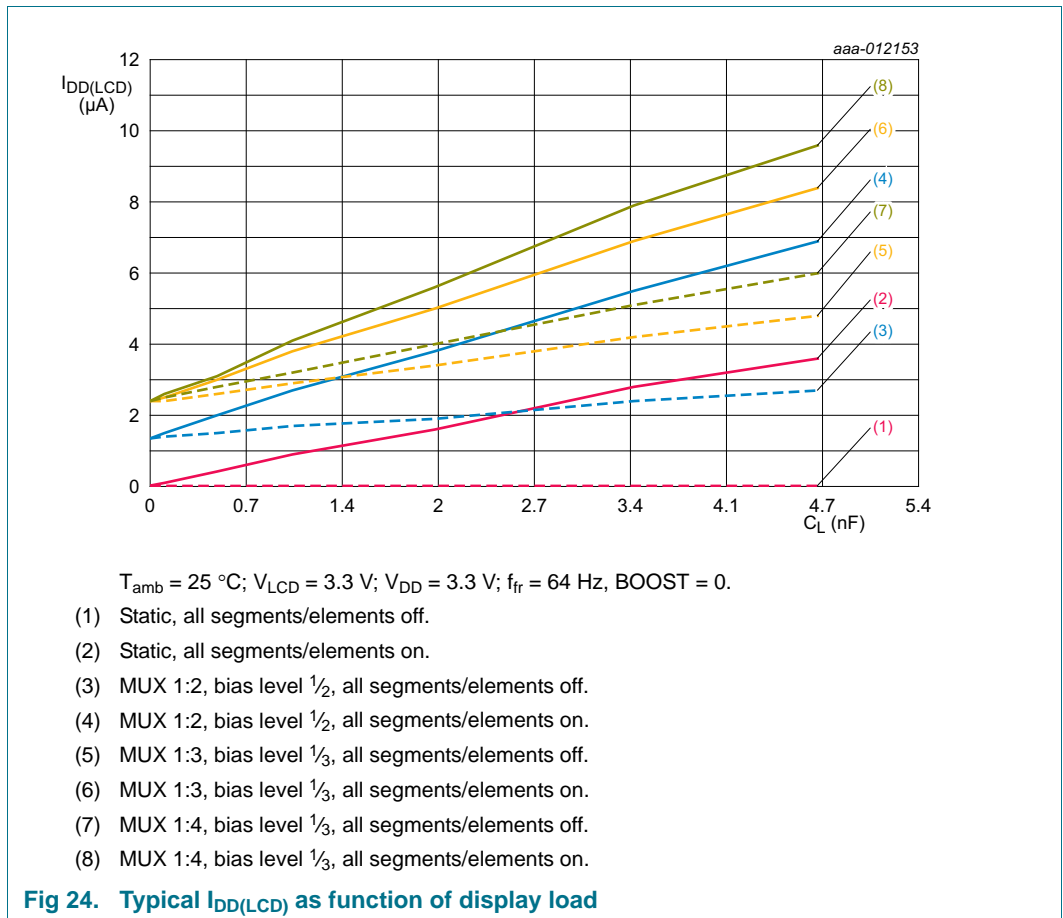
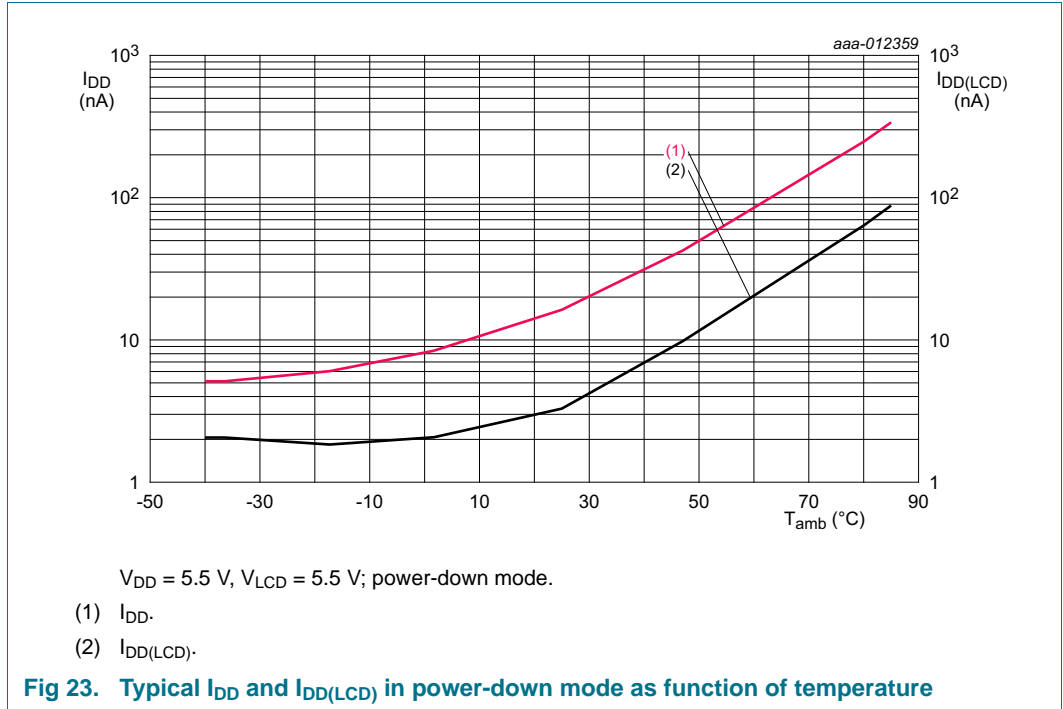

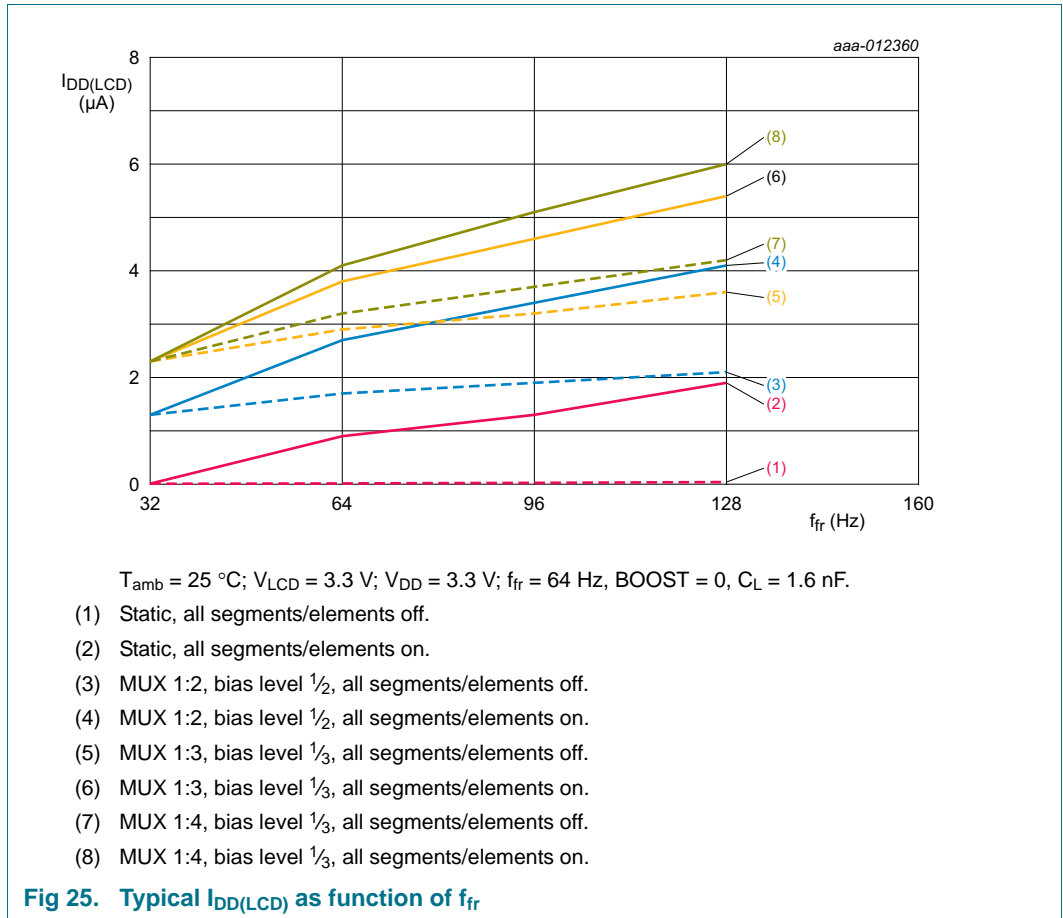

Table 19. Frequency characteristics

$V_{DD} = 1.8\text{ V to }5.5\text{ V}; V_{SS} = 0\text{ V}; V_{LCD} = 1.8\text{ V to }5.5\text{ V}; T_{amb} = -40\text{ °C to }+85\text{ °C};$ unless otherwise specified.

Symbol	Parameter	Conditions	Min	Typ	Max	Unit
f_{fr}	frame frequency	FF[1:0] = 00	-	32	-	Hz
		FF[1:0] = 01	42	64	86	Hz
		FF[1:0] = 10	-	96	-	Hz
		FF[1:0] = 11	-	128	-	Hz
$f_{clk(int)}$	internal clock frequency	$f_{fr} = 64\text{ Hz}, n_{MUX} = 4$	[1]	1024	-	Hz
$f_{clk(ext)}$	external clock frequency		[1]	-	4096	Hz
$t_{clk(H)}$	HIGH-level clock time	external clock	60	-	-	µs
$t_{clk(L)}$	LOW-level clock time	external clock	60	-	-	µs
$t_{w(rst)}$	reset pulse width	on pin \overline{RST}	10	-	-	µs

[1] $f_{clk(int)} = 2 \cdot f_{fr} \cdot n_{MUX}$ or $f_{clk(ext)} = 2 \cdot f_{fr} \cdot n_{MUX}$ respectively (see Table 6 and Table 7).

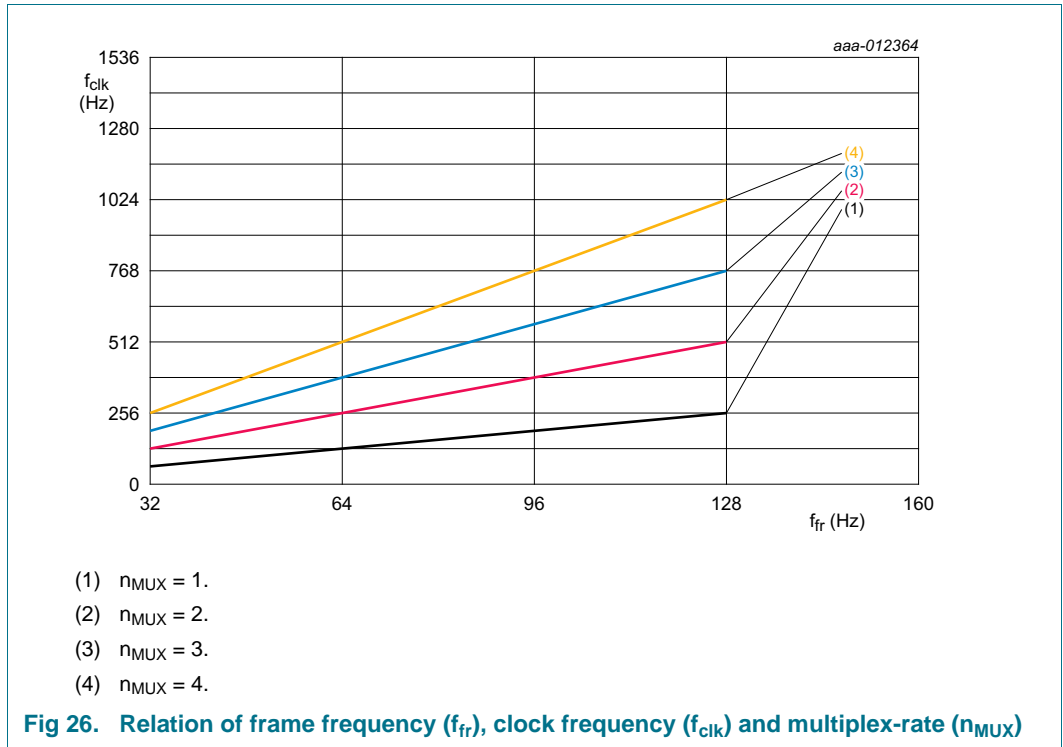

Table 20. I²C-bus characteristics

$V_{DD} = 1.8\text{ V to }5.5\text{ V}$; $V_{SS} = 0\text{ V}$; $T_{amb} = -40\text{ °C to }+85\text{ °C}$; unless otherwise specified; all timing values are valid within the operating supply voltage and T_{amb} range and are referenced to V_{IL} and V_{IH} with an input voltage swing of V_{SS} to V_{DD} .^[1]

Symbol	Parameter	Conditions	Min	Typ	Max	Unit
Pin SCL						
f_{SCL}	SCL clock frequency		-	-	400	kHz
t_{LOW}	LOW period of the SCL clock		1.3	-	-	μs
t_{HIGH}	HIGH period of the SCL clock		0.6	-	-	μs
Pin SDA						
$t_{SU;DAT}$	data set-up time		100	-	-	ns
$t_{HD;DAT}$	data hold time		0	-	-	ns
Pins SCL and SDA						
t_{BUF}	bus free time between a STOP and START condition		1.3	-	-	μs
$t_{SU;STO}$	set-up time for STOP condition		0.6	-	-	μs
$t_{HD;STA}$	hold time (repeated) START condition		0.6	-	-	μs
$t_{SU;STA}$	set-up time for a repeated START condition		0.6	-	-	μs
t_r	rise time of both SDA and SCL signals	$f_{SCL} = 400\text{ kHz}$	-	-	0.3	μs
t_f	fall time of both SDA and SCL signals		-	-	0.3	μs
C_b	capacitive load for each bus line		-	-	400	pF
$t_{w(\text{spike})}$	spike pulse width	on the I ² C-bus	-	-	50	ns

[1] The I²C-bus interface of PCF8551A is 5 V tolerant.

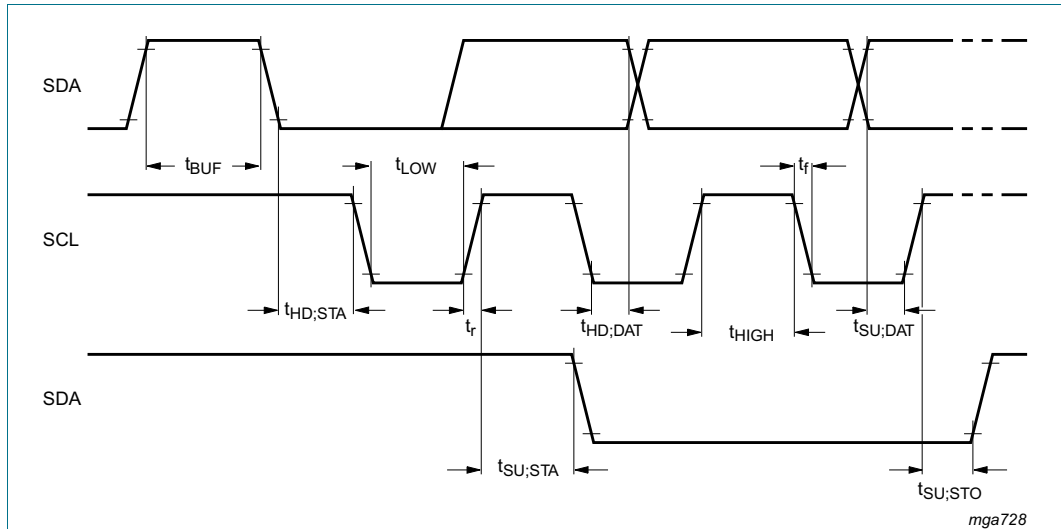

Fig 27. I²C-bus timing waveforms

Table 21. SPI-bus characteristics

$V_{DD} = 1.8\text{ V to }5.5\text{ V}$; $V_{SS} = 0\text{ V}$; $T_{amb} = -40\text{ °C to }+85\text{ °C}$; unless otherwise specified; all timing values are valid within the operating supply voltage and T_{amb} range and are referenced to V_{IL} and V_{IH} with an input voltage swing of V_{SS} to V_{DD} .

Symbol	Parameter	Conditions	Min	Typ	Max	Unit
Pin SCL						
f_{SCL}	SCL clock frequency		-	-	5	MHz
t_{LOW}	LOW period of the SCL clock		150	-	-	ns
t_{HIGH}	HIGH period of the SCL clock		80	-	-	ns
t_r	rise time		-	-	100	ns
t_f	fall time		-	-	100	ns
Pin CE						
$t_{su(CE_N)}$	CE_N set-up time		30	-	-	ns
$t_{h(CE_N)}$	CE_N hold time		10	-	-	ns
$t_{rec(CE_N)}$	CE_N recovery time		70	-	-	ns
Pin SDIO						
t_{su}	set-up time	write data	5	-	-	ns
t_h	hold time	write data	50	-	-	ns
$t_{d(R)SDIO}$	SDIO read delay time	$C_L = 50\text{ pF}$	-	-	150	ns
$t_{dis(SDIO)}$	SDIO disable time	no load	-	-	50	ns
$t_t(SDI\text{-}SDO)$	transition time from SDI to SDO	write to read mode	0	-	-	ns

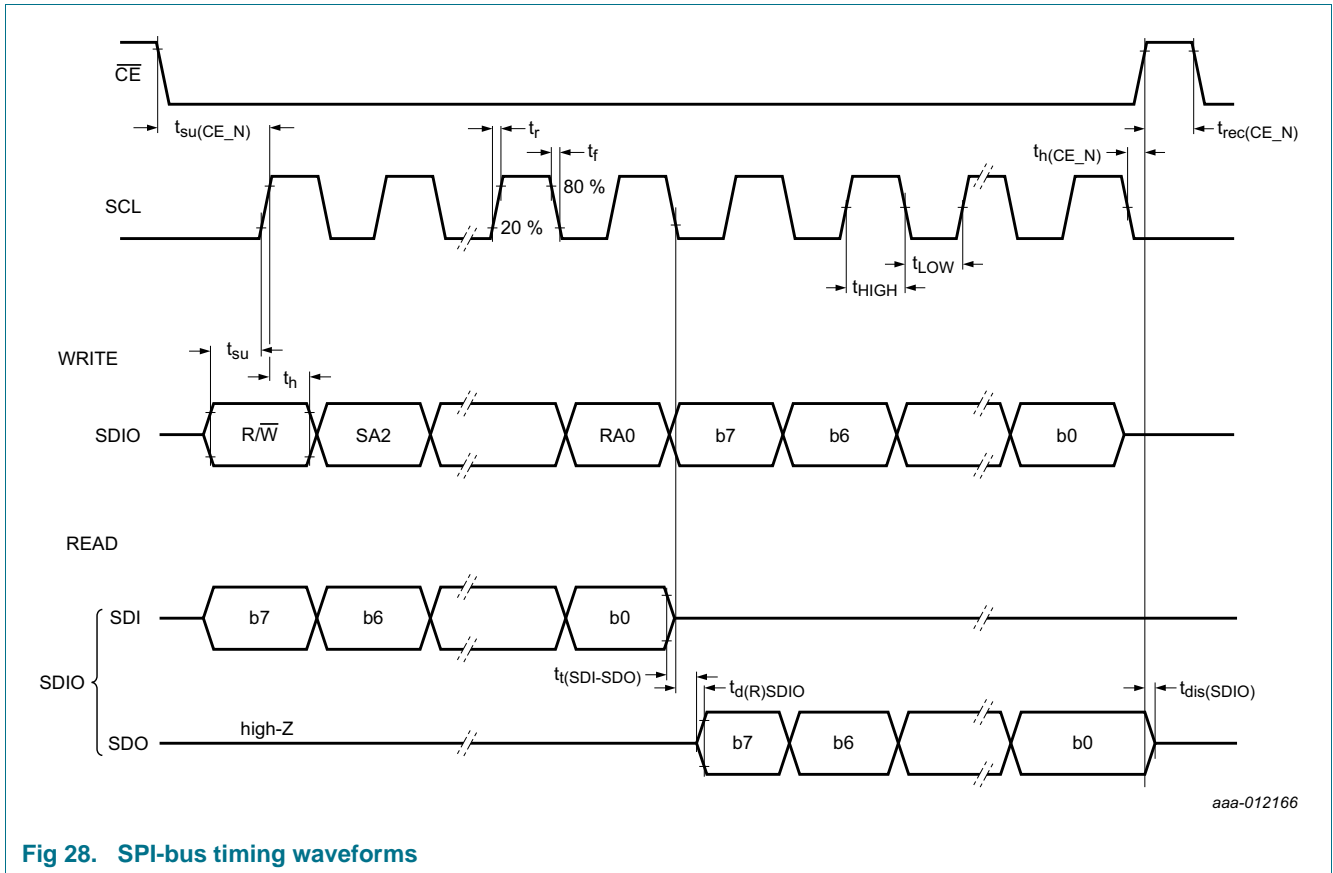

Fig 28. SPI-bus timing waveforms

16. Application information

16.1 Power-on with a slowly starting power supply

The built-in POR block acts on the rising edge of the V_{DD} supply voltage. It is designed to react to fast slopes. If the system supply starts slowly, it is recommended to initiate a software reset immediately after power-on.

16.2 I²C acknowledge after power-on

If the bus does not show an acknowledge at the first access, the command should be sent a second time.

16.3 Resistors on I/O pins

The pin PORE comprises an internal, latching pull-down device, which keeps the input at a low potential when left open. If the input is supposed to be at logic 0 potential, this pin can be either connected to V_{SS} or left open.

In case the pin is supposed to be at logic 1 potential, it must be connected to V_{DD} to avoid any cross-current during power-up. A series resistance between V_{DD} and PORE must not exceed 1 k Ω to ensure proper functionality.

17. Package outline

TSSOP48: plastic thin shrink small outline package; 48 leads; body width 6.1 mm

SOT362-1

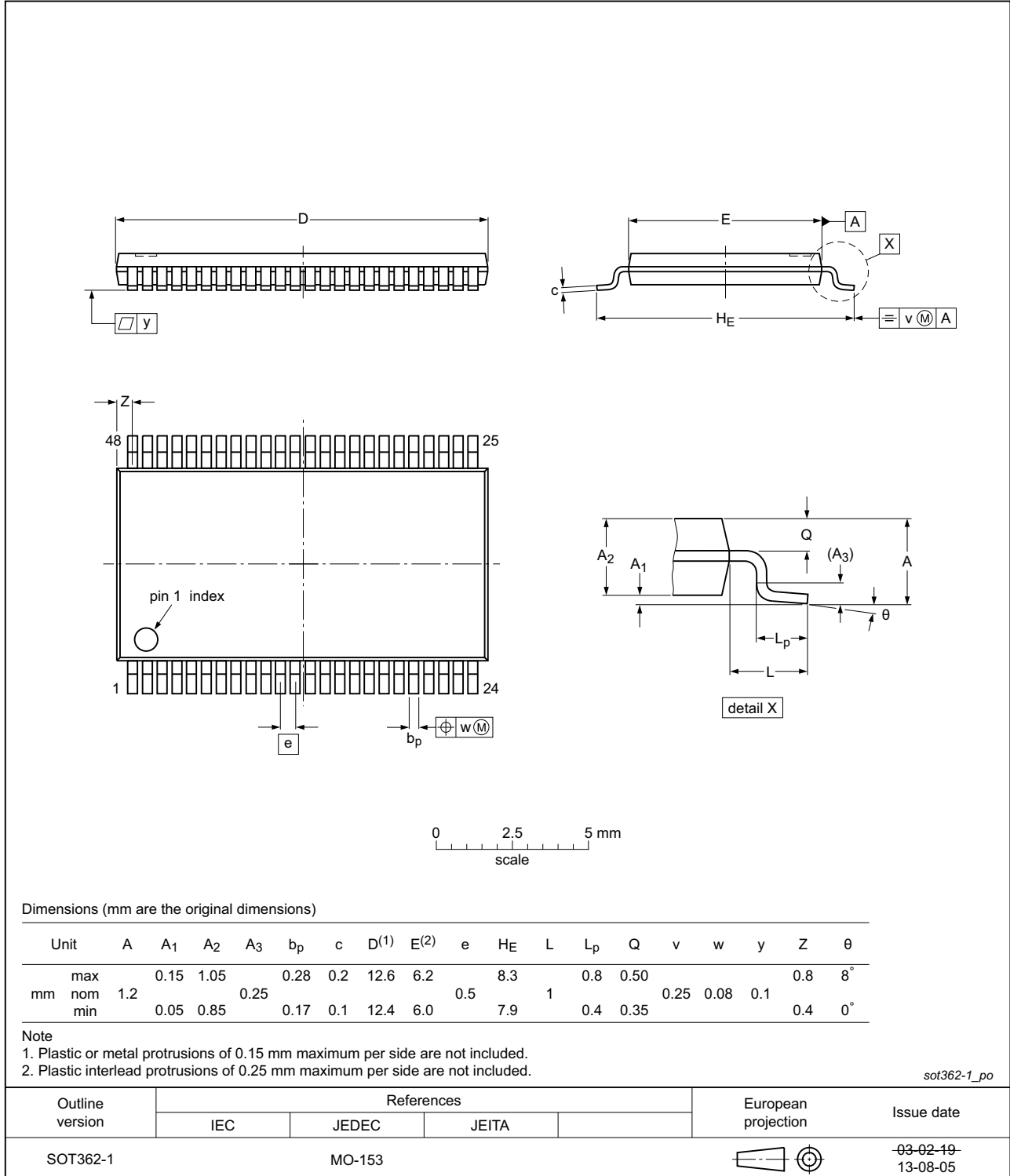

Fig 29. Package outline SOT362-1 (TSSOP48) of PCF8551

18. Handling information

All input and output pins are protected against ElectroStatic Discharge (ESD) under normal handling. When handling Metal-Oxide Semiconductor (MOS) devices ensure that all normal precautions are taken as described in *JESD625-A*, *IEC 61340-5* or equivalent standards.

19. Packing information

19.1 Tape and reel information

For tape and reel packing information, see [Ref. 11 "SOT362-1_118" on page 48](#).

20. Soldering of SMD packages

This text provides a very brief insight into a complex technology. A more in-depth account of soldering ICs can be found in Application Note *AN10365 "Surface mount reflow soldering description"*.

20.1 Introduction to soldering

Soldering is one of the most common methods through which packages are attached to Printed Circuit Boards (PCBs), to form electrical circuits. The soldered joint provides both the mechanical and the electrical connection. There is no single soldering method that is ideal for all IC packages. Wave soldering is often preferred when through-hole and Surface Mount Devices (SMDs) are mixed on one printed wiring board; however, it is not suitable for fine pitch SMDs. Reflow soldering is ideal for the small pitches and high densities that come with increased miniaturization.

20.2 Wave and reflow soldering

Wave soldering is a joining technology in which the joints are made by solder coming from a standing wave of liquid solder. The wave soldering process is suitable for the following:

- Through-hole components
- Leaded or leadless SMDs, which are glued to the surface of the printed circuit board

Not all SMDs can be wave soldered. Packages with solder balls, and some leadless packages which have solder lands underneath the body, cannot be wave soldered. Also, leaded SMDs with leads having a pitch smaller than ~0.6 mm cannot be wave soldered, due to an increased probability of bridging.

The reflow soldering process involves applying solder paste to a board, followed by component placement and exposure to a temperature profile. Leaded packages, packages with solder balls, and leadless packages are all reflow solderable.

Key characteristics in both wave and reflow soldering are:

- Board specifications, including the board finish, solder masks and vias
- Package footprints, including solder thieves and orientation
- The moisture sensitivity level of the packages

- Package placement
- Inspection and repair
- Lead-free soldering versus SnPb soldering

20.3 Wave soldering

Key characteristics in wave soldering are:

- Process issues, such as application of adhesive and flux, clinching of leads, board transport, the solder wave parameters, and the time during which components are exposed to the wave
- Solder bath specifications, including temperature and impurities

20.4 Reflow soldering

Key characteristics in reflow soldering are:

- Lead-free versus SnPb soldering; note that a lead-free reflow process usually leads to higher minimum peak temperatures (see [Figure 30](#)) than a SnPb process, thus reducing the process window
- Solder paste printing issues including smearing, release, and adjusting the process window for a mix of large and small components on one board
- Reflow temperature profile; this profile includes preheat, reflow (in which the board is heated to the peak temperature) and cooling down. It is imperative that the peak temperature is high enough for the solder to make reliable solder joints (a solder paste characteristic). In addition, the peak temperature must be low enough that the packages and/or boards are not damaged. The peak temperature of the package depends on package thickness and volume and is classified in accordance with [Table 22](#) and [23](#)

Table 22. SnPb eutectic process (from J-STD-020D)

Package thickness (mm)	Package reflow temperature (°C)	
	Volume (mm ³)	
	< 350	≥ 350
< 2.5	235	220
≥ 2.5	220	220

Table 23. Lead-free process (from J-STD-020D)

Package thickness (mm)	Package reflow temperature (°C)		
	Volume (mm ³)		
	< 350	350 to 2000	> 2000
< 1.6	260	260	260
1.6 to 2.5	260	250	245
> 2.5	250	245	245

Moisture sensitivity precautions, as indicated on the packing, must be respected at all times.

Studies have shown that small packages reach higher temperatures during reflow soldering, see [Figure 30](#).

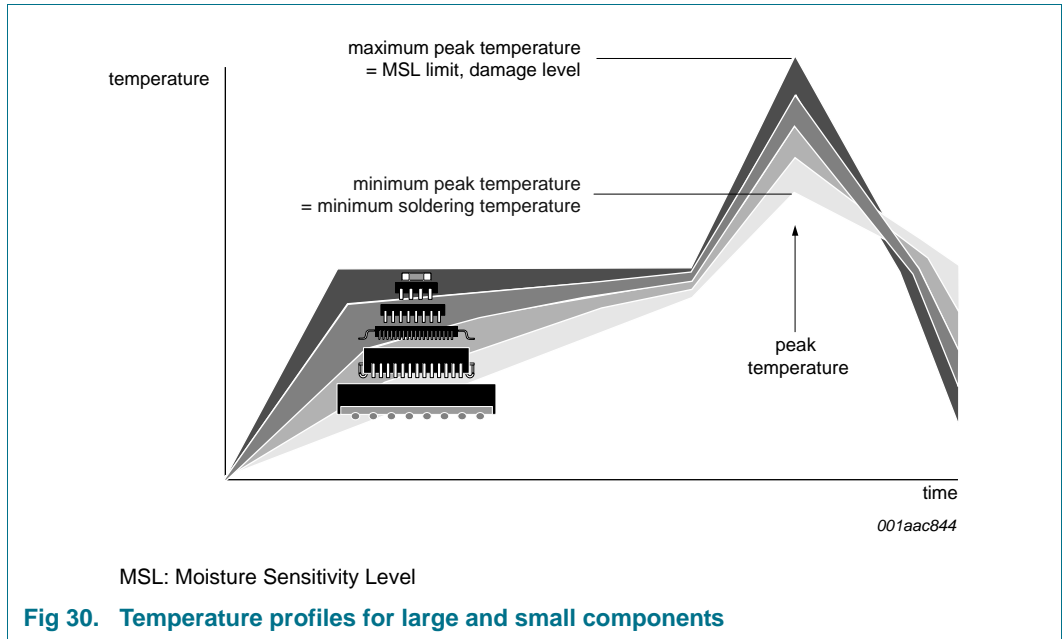

For further information on temperature profiles, refer to Application Note AN10365 "Surface mount reflow soldering description".

21. Footprint information

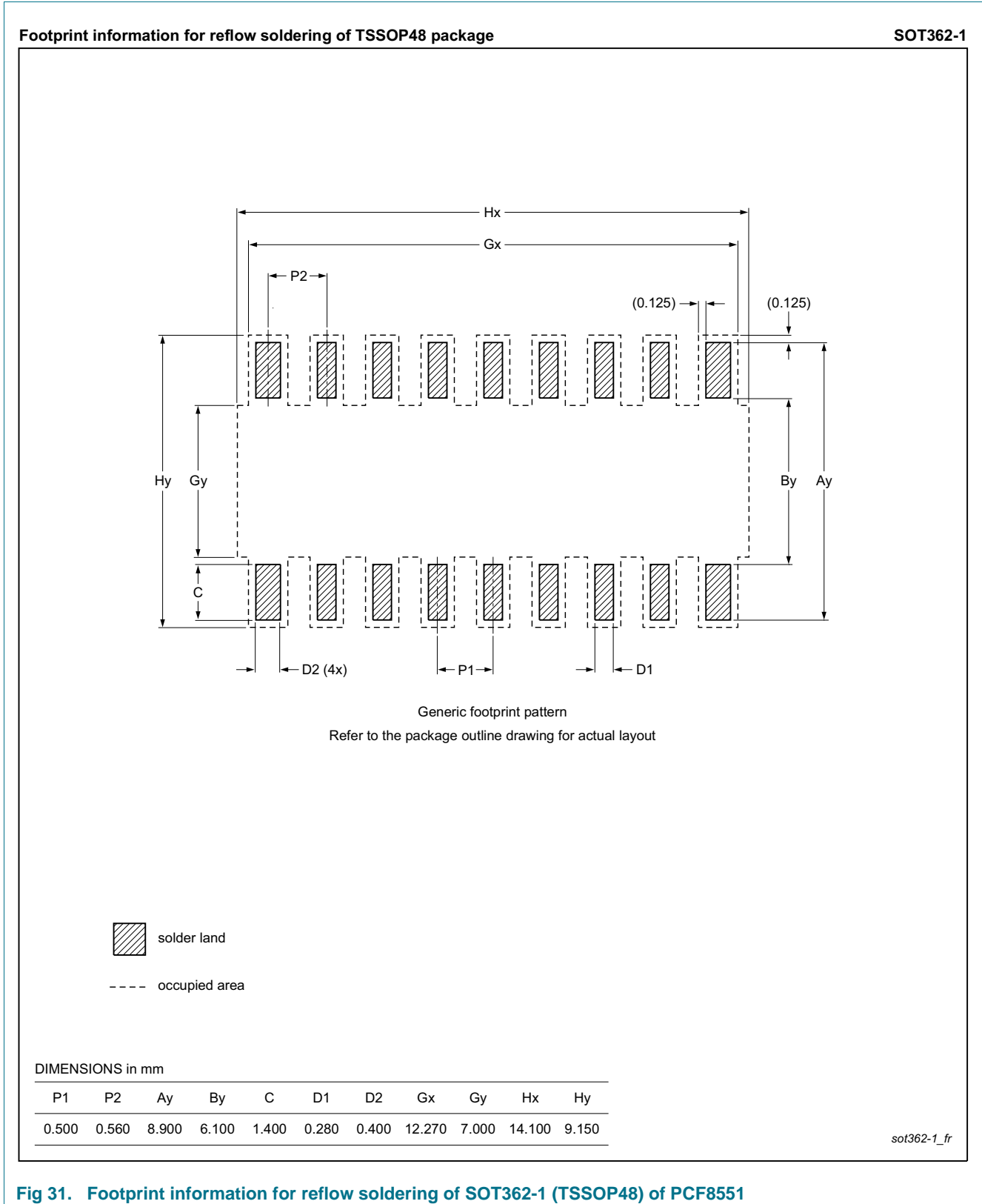

Fig 31. Footprint information for reflow soldering of SOT362-1 (TSSOP48) of PCF8551

22. Appendix

22.1 LCD segment driver selection

Table 24. Selection of LCD segment drivers

Type name	Number of elements at MUX							V _{DD} (V)	V _{LCD} (V)	f _{fr} (Hz)	V _{LCD} (V) charge pump	V _{LCD} (V) temperature compensat.	T _{amb} (°C)	Interface	Package	AEC- Q100
	1:1	1:2	1:3	1:4	1:6	1:8	1:9									
PCA8553DTT	40	80	120	160	-	-	-	1.8 to 5.5	1.8 to 5.5	32 to 256 ^[1]	N	N	-40 to 105	I ² C / SPI	TSSOP56	Y
PCA8546ATT	-	-	-	176	-	-	-	1.8 to 5.5	2.5 to 9	60 to 300 ^[1]	N	N	-40 to 95	I ² C	TSSOP56	Y
PCA8546BTT	-	-	-	176	-	-	-	1.8 to 5.5	2.5 to 9	60 to 300 ^[1]	N	N	-40 to 95	SPI	TSSOP56	Y
PCA8547AHT	44	88	-	176	-	-	-	1.8 to 5.5	2.5 to 9	60 to 300 ^[1]	Y	Y	-40 to 95	I ² C	TQFP64	Y
PCA8547BHT	44	88	-	176	-	-	-	1.8 to 5.5	2.5 to 9	60 to 300 ^[1]	Y	Y	-40 to 95	SPI	TQFP64	Y
PCF85134HL	60	120	180	240	-	-	-	1.8 to 5.5	2.5 to 6.5	82	N	N	-40 to 85	I ² C	LQFP80	N
PCA85134H	60	120	180	240	-	-	-	1.8 to 5.5	2.5 to 8	82	N	N	-40 to 95	I ² C	LQFP80	Y
PCA8543AHL	60	120	-	240	-	-	-	2.5 to 5.5	2.5 to 9	60 to 300 ^[1]	Y	Y	-40 to 105	I ² C	LQFP80	Y
PCF8545ATT	-	-	-	176	252	320	-	1.8 to 5.5	2.5 to 5.5	60 to 300 ^[1]	N	N	-40 to 85	I ² C	TSSOP56	N
PCF8545BTT	-	-	-	176	252	320	-	1.8 to 5.5	2.5 to 5.5	60 to 300 ^[1]	N	N	-40 to 85	SPI	TSSOP56	N
PCF8536AT	-	-	-	176	252	320	-	1.8 to 5.5	2.5 to 9	60 to 300 ^[1]	N	N	-40 to 85	I ² C	TSSOP56	N
PCF8536BT	-	-	-	176	252	320	-	1.8 to 5.5	2.5 to 9	60 to 300 ^[1]	N	N	-40 to 85	SPI	TSSOP56	N
PCA8536AT	-	-	-	176	252	320	-	1.8 to 5.5	2.5 to 9	60 to 300 ^[1]	N	N	-40 to 95	I ² C	TSSOP56	Y
PCA8536BT	-	-	-	176	252	320	-	1.8 to 5.5	2.5 to 9	60 to 300 ^[1]	N	N	-40 to 95	SPI	TSSOP56	Y
PCF8537AH	44	88	-	176	276	352	-	1.8 to 5.5	2.5 to 9	60 to 300 ^[1]	Y	Y	-40 to 85	I ² C	TQFP64	N
PCF8537BH	44	88	-	176	276	352	-	1.8 to 5.5	2.5 to 9	60 to 300 ^[1]	Y	Y	-40 to 85	SPI	TQFP64	N
PCA8537AH	44	88	-	176	276	352	-	1.8 to 5.5	2.5 to 9	60 to 300 ^[1]	Y	Y	-40 to 95	I ² C	TQFP64	Y
PCA8537BH	44	88	-	176	276	352	-	1.8 to 5.5	2.5 to 9	60 to 300 ^[1]	Y	Y	-40 to 95	SPI	TQFP64	Y
PCA9620H	60	120	-	240	320	480	-	2.5 to 5.5	2.5 to 9	60 to 300 ^[1]	Y	Y	-40 to 105	I ² C	LQFP80	Y
PCA9620U	60	120	-	240	320	480	-	2.5 to 5.5	2.5 to 9	60 to 300 ^[1]	Y	Y	-40 to 105	I ² C	Bare die	Y
PCF8576DU	40	80	120	160	-	-	-	1.8 to 5.5	2.5 to 6.5	77	N	N	-40 to 85	I ² C	Bare die	N
PCF8576EUG	40	80	120	160	-	-	-	1.8 to 5.5	2.5 to 6.5	77	N	N	-40 to 85	I ² C	Bare die	N
PCA8576FUG	40	80	120	160	-	-	-	1.8 to 5.5	2.5 to 8	200	N	N	-40 to 105	I ² C	Bare die	Y
PCF85133U	80	160	240	320	-	-	-	1.8 to 5.5	2.5 to 6.5	82, 110 ^[2]	N	N	-40 to 85	I ² C	Bare die	N
PCA85133U	80	160	240	320	-	-	-	1.8 to 5.5	2.5 to 8	82, 110 ^[2]	N	N	-40 to 95	I ² C	Bare die	Y

Table 24. Selection of LCD segment drivers ...continued

Type name	Number of elements at MUX							V _{DD} (V)	V _{LCD} (V)	f _{fr} (Hz)	V _{LCD} (V) charge pump	V _{LCD} (V) temperature compensat.	T _{amb} (°C)	Interface	Package	AEC- Q100
	1:1	1:2	1:3	1:4	1:6	1:8	1:9									
PCA85233UG	80	160	240	320	-	-	-	1.8 to 5.5	2.5 to 8	150, 220 ^[2]	N	N	-40 to 105	I ² C	Bare die	Y
PCF85132U	160	320	480	640	-	-	-	1.8 to 5.5	1.8 to 8	60 to 90 ^[1]	N	N	-40 to 85	I ² C	Bare die	N
PCA8530DUG	102	204	-	408	-	-	-	2.5 to 5.5	4 to 12	45 to 300 ^[1]	Y	Y	-40 to 105	I ² C / SPI	Bare die	Y
PCA85132U	160	320	480	640	-	-	-	1.8 to 5.5	1.8 to 8	60 to 90 ^[1]	N	N	-40 to 95	I ² C	Bare die	Y
PCA85232U	160	320	480	640	-	-	-	1.8 to 5.5	1.8 to 8	117 to 176 ^[1]	N	N	-40 to 95	I ² C	Bare die	Y
PCF8538UG	102	204	-	408	612	816	918	2.5 to 5.5	4 to 12	45 to 300 ^[1]	Y	Y	-40 to 85	I ² C / SPI	Bare die	N
PCA8538UG	102	204	-	408	612	816	918	2.5 to 5.5	4 to 12	45 to 300 ^[1]	Y	Y	-40 to 105	I ² C / SPI	Bare die	Y

[1] Software programmable.

[2] Hardware selectable.

23. Abbreviations

Table 25. Abbreviations

Acronym	Description
CDM	Charged-Device Model
DC	Direct Current
EMC	ElectroMagnetic Compatibility
ESD	ElectroStatic Discharge
HBM	Human Body Model
I ² C	Inter-Integrated Circuit bus
IC	Integrated Circuit
LCD	Liquid Crystal Display
LSB	Least Significant Bit
MSB	Most Significant Bit
MSL	Moisture Sensitivity Level
MUX	Multiplexer
PCB	Printed-Circuit Board
POR	Power-On Reset
RC	Resistance-Capacitance
RMS	Root Mean Square
SCL	Serial CLock line
SDA	Serial DATa line
SMD	Surface-Mount Device
SPI	Serial Peripheral Interface

24. References

- [1] **AN10365** — Surface mount reflow soldering description
- [2] **AN10853** — ESD and EMC sensitivity of IC
- [3] **AN11267** — EMC and system level ESD design guidelines for LCD drivers
- [4] **IEC 60134** — Rating systems for electronic tubes and valves and analogous semiconductor devices
- [5] **IEC 61340-5** — Protection of electronic devices from electrostatic phenomena
- [6] **IPC/JEDEC J-STD-020D** — Moisture/Reflow Sensitivity Classification for Nonhermetic Solid State Surface Mount Devices
- [7] **JESD22-A114** — Electrostatic Discharge (ESD) Sensitivity Testing Human Body Model (HBM)
- [8] **JESD22-C101** — Field-Induced Charged-Device Model Test Method for Electrostatic-Discharge-Withstand Thresholds of Microelectronic Components
- [9] **JESD78** — IC Latch-Up Test
- [10] **JESD625-A** — Requirements for Handling Electrostatic-Discharge-Sensitive (ESDS) Devices
- [11] **SOT362-1_118** — TSSOP48; Reel pack; SMD, 13", packing information
- [12] **UM10204** — I²C-bus specification and user manual
- [13] **UM10569** — Store and transport requirements

25. Revision history

Table 26. Revision history

Document ID	Release date	Data sheet status	Change notice	Supersedes
PCF8551 v.2	20150216	Product data sheet	-	PCF8551 v.1
Modifications:	<ul style="list-style-type: none">Adjusted I_{DD} and $I_{DD(LCD)}$ values in Table 18Switched to Product data sheet			
PCF8551 v.1	20141205	Objective data sheet	-	-

26. Legal information

26.1 Data sheet status

Document status ^{[1][2]}	Product status ^[3]	Definition
Objective [short] data sheet	Development	This document contains data from the objective specification for product development.
Preliminary [short] data sheet	Qualification	This document contains data from the preliminary specification.
Product [short] data sheet	Production	This document contains the product specification.

[1] Please consult the most recently issued document before initiating or completing a design.

[2] The term 'short data sheet' is explained in section "Definitions".

[3] The product status of device(s) described in this document may have changed since this document was published and may differ in case of multiple devices. The latest product status information is available on the Internet at URL <http://www.nxp.com>.

26.2 Definitions

Draft — The document is a draft version only. The content is still under internal review and subject to formal approval, which may result in modifications or additions. NXP Semiconductors does not give any representations or warranties as to the accuracy or completeness of information included herein and shall have no liability for the consequences of use of such information.

Short data sheet — A short data sheet is an extract from a full data sheet with the same product type number(s) and title. A short data sheet is intended for quick reference only and should not be relied upon to contain detailed and full information. For detailed and full information see the relevant full data sheet, which is available on request via the local NXP Semiconductors sales office. In case of any inconsistency or conflict with the short data sheet, the full data sheet shall prevail.

Product specification — The information and data provided in a Product data sheet shall define the specification of the product as agreed between NXP Semiconductors and its customer, unless NXP Semiconductors and customer have explicitly agreed otherwise in writing. In no event however, shall an agreement be valid in which the NXP Semiconductors product is deemed to offer functions and qualities beyond those described in the Product data sheet.

26.3 Disclaimers

Limited warranty and liability — Information in this document is believed to be accurate and reliable. However, NXP Semiconductors does not give any representations or warranties, expressed or implied, as to the accuracy or completeness of such information and shall have no liability for the consequences of use of such information. NXP Semiconductors takes no responsibility for the content in this document if provided by an information source outside of NXP Semiconductors.

In no event shall NXP Semiconductors be liable for any indirect, incidental, punitive, special or consequential damages (including - without limitation - lost profits, lost savings, business interruption, costs related to the removal or replacement of any products or rework charges) whether or not such damages are based on tort (including negligence), warranty, breach of contract or any other legal theory.

Notwithstanding any damages that customer might incur for any reason whatsoever, NXP Semiconductors' aggregate and cumulative liability towards customer for the products described herein shall be limited in accordance with the *Terms and conditions of commercial sale* of NXP Semiconductors.

Right to make changes — NXP Semiconductors reserves the right to make changes to information published in this document, including without limitation specifications and product descriptions, at any time and without notice. This document supersedes and replaces all information supplied prior to the publication hereof.

Suitability for use — NXP Semiconductors products are not designed, authorized or warranted to be suitable for use in life support, life-critical or safety-critical systems or equipment, nor in applications where failure or malfunction of an NXP Semiconductors product can reasonably be expected to result in personal injury, death or severe property or environmental damage. NXP Semiconductors and its suppliers accept no liability for inclusion and/or use of NXP Semiconductors products in such equipment or applications and therefore such inclusion and/or use is at the customer's own risk.

Applications — Applications that are described herein for any of these products are for illustrative purposes only. NXP Semiconductors makes no representation or warranty that such applications will be suitable for the specified use without further testing or modification.

Customers are responsible for the design and operation of their applications and products using NXP Semiconductors products, and NXP Semiconductors accepts no liability for any assistance with applications or customer product design. It is customer's sole responsibility to determine whether the NXP Semiconductors product is suitable and fit for the customer's applications and products planned, as well as for the planned application and use of customer's third party customer(s). Customers should provide appropriate design and operating safeguards to minimize the risks associated with their applications and products.

NXP Semiconductors does not accept any liability related to any default, damage, costs or problem which is based on any weakness or default in the customer's applications or products, or the application or use by customer's third party customer(s). Customer is responsible for doing all necessary testing for the customer's applications and products using NXP Semiconductors products in order to avoid a default of the applications and the products or of the application or use by customer's third party customer(s). NXP does not accept any liability in this respect.

Limiting values — Stress above one or more limiting values (as defined in the Absolute Maximum Ratings System of IEC 60134) will cause permanent damage to the device. Limiting values are stress ratings only and (proper) operation of the device at these or any other conditions above those given in the Recommended operating conditions section (if present) or the Characteristics sections of this document is not warranted. Constant or repeated exposure to limiting values will permanently and irreversibly affect the quality and reliability of the device.

Terms and conditions of commercial sale — NXP Semiconductors products are sold subject to the general terms and conditions of commercial sale, as published at <http://www.nxp.com/profile/terms>, unless otherwise agreed in a valid written individual agreement. In case an individual agreement is concluded only the terms and conditions of the respective agreement shall apply. NXP Semiconductors hereby expressly objects to applying the customer's general terms and conditions with regard to the purchase of NXP Semiconductors products by customer.

No offer to sell or license — Nothing in this document may be interpreted or construed as an offer to sell products that is open for acceptance or the grant, conveyance or implication of any license under any copyrights, patents or other industrial or intellectual property rights.

Export control — This document as well as the item(s) described herein may be subject to export control regulations. Export might require a prior authorization from competent authorities.

Non-automotive qualified products — Unless this data sheet expressly states that this specific NXP Semiconductors product is automotive qualified, the product is not suitable for automotive use. It is neither qualified nor tested in accordance with automotive testing or application requirements. NXP Semiconductors accepts no liability for inclusion and/or use of non-automotive qualified products in automotive equipment or applications.

In the event that customer uses the product for design-in and use in automotive applications to automotive specifications and standards, customer (a) shall use the product without NXP Semiconductors' warranty of the product for such automotive applications, use and specifications, and (b) whenever customer uses the product for automotive applications beyond

NXP Semiconductors' specifications such use shall be solely at customer's own risk, and (c) customer fully indemnifies NXP Semiconductors for any liability, damages or failed product claims resulting from customer design and use of the product for automotive applications beyond NXP Semiconductors' standard warranty and NXP Semiconductors' product specifications.

Translations — A non-English (translated) version of a document is for reference only. The English version shall prevail in case of any discrepancy between the translated and English versions.

26.4 Trademarks

Notice: All referenced brands, product names, service names and trademarks are the property of their respective owners.

27. Contact information

For more information, please visit: <http://www.nxp.com>

For sales office addresses, please send an email to: salesaddresses@nxp.com

28. Tables

Table 1.	Ordering information	2
Table 2.	Ordering options	2
Table 3.	Marking codes	2
Table 4.	Pin description	6
Table 5.	Registers of the PCF8551	7
Table 6.	Device_ctrl - device control command register (address 01h) bit description	8
Table 7.	Display_ctrl_1 - display control command 1 register (address 02h) bit description	9
Table 8.	Display_ctrl_2 - display control command 2 register (address 03h) bit description	10
Table 9.	Software_reset - software reset command register (address 00h) bit description	11
Table 10.	Register to segment and backplane mapping	12
Table 11.	Selection of possible display configurations	14
Table 12.	Biasing characteristics	16
Table 13.	I ² C slave address byte	28
Table 14.	R/W-bit description	28
Table 15.	Serial interface	29
Table 16.	Address byte definition	29
Table 17.	Limiting values	32
Table 18.	Electrical characteristics	33
Table 19.	Frequency characteristics	35
Table 20.	I ² C-bus characteristics	37
Table 21.	SPI-bus characteristics	38
Table 22.	SnPb eutectic process (from J-STD-020D)	42
Table 23.	Lead-free process (from J-STD-020D)	42
Table 24.	Selection of LCD segment drivers	45
Table 25.	Abbreviations	47
Table 26.	Revision history	49

29. Figures

Fig 1.	Block diagram of PCF8551A	3
Fig 2.	Block diagram of PCF8551B	3
Fig 3.	Pin configuration of PCF8551ATT (TSSOP48)	4
Fig 4.	Pin configuration of PCF8551BTT (TSSOP48)	5
Fig 5.	Address counter incrementing	8
Fig 6.	Display RAM organization bitmap for MUX 1:4	13
Fig 7.	Example of displays suitable for PCF8551	14
Fig 8.	Typical system configuration using I ² C-bus, internal power-on reset disabled	15
Fig 9.	Typical system configuration using SPI-bus, internal power-on reset enabled	15
Fig 10.	Electro-optical characteristic: relative transmission curve of the liquid	18
Fig 11.	Static drive mode waveforms	19
Fig 12.	Waveforms for the 1:2 multiplex drive mode with 1/2 bias	20
Fig 13.	Waveforms for the 1:2 multiplex drive mode with 1/3 bias	21
Fig 14.	Waveforms for the 1:3 multiplex drive mode with 1/3 bias	22
Fig 15.	Waveforms for the 1:4 multiplex drive mode with 1/3 bias	23
Fig 16.	Recommended power-up and power-off sequence	25
Fig 17.	I ² C read and write protocol	26
Fig 18.	I ² C read and write signaling	26
Fig 19.	Data transfer overview	29
Fig 20.	SPI-bus write example: writing two data bytes to registers 00h and 01h	30
Fig 21.	SPI-bus read example: reading two data bytes from registers 04h and 05h	30
Fig 22.	Device protection diagram	31
Fig 23.	Typical I _{DD} and I _{DD(LCD)} in power-down mode as function of temperature	34
Fig 24.	Typical I _{DD(LCD)} as function of display load	34
Fig 25.	Typical I _{DD(LCD)} as function of f _{fr}	35
Fig 26.	Relation of frame frequency (f _{fr}), clock frequency (f _{clk}) and multiplex-rate (n _{MUX})	36
Fig 27.	I ² C-bus timing waveforms	38
Fig 28.	SPI-bus timing waveforms	39
Fig 29.	Package outline SOT362-1 (TSSOP48) of PCF8551	40
Fig 30.	Temperature profiles for large and small components	43
Fig 31.	Footprint information for reflow soldering of SOT362-1 (TSSOP48) of PCF8551	44

30. Contents

1	General description	1	11.1.2	START and STOP conditions	27
2	Features and benefits	1	11.1.3	Acknowledge	27
3	Applications	1	11.1.4	I ² C interface protocol	27
4	Ordering information	2	11.1.4.1	Write protocol	27
4.1	Ordering options	2	11.1.4.2	Read protocol	28
5	Marking	2	11.1.4.3	I ² C-bus slave address	28
6	Block diagram	3	11.2	SPI-bus interface of the PCF8551B	29
7	Pinning information	4	11.2.1	Data transmission	29
7.1	Pinning	4	11.2.1.1	Write protocol	29
7.2	Pin description	6	11.2.1.2	Read protocol	30
8	Functional description	7	11.3	EMC detection	31
8.1	Registers of the PCF8551	7	12	Internal circuitry	31
8.2	Command registers of the PCF8551	8	13	Safety notes	31
8.2.1	Command: Device_ctrl	8	14	Limiting values	32
8.2.1.1	Internal oscillator and clock output	8	15	Characteristics	33
8.2.2	Command: Display_ctrl_1	9	16	Application information	39
8.2.2.1	Enhanced power drive mode	9	16.1	Power-on with a slowly starting power supply	39
8.2.2.2	Multiplex drive mode	9	16.2	I ² C acknowledge after power-on	39
8.2.3	Command: Display_ctrl_2	10	16.3	Resistors on I/O pins	39
8.2.3.1	Blinking	10	17	Package outline	40
8.2.3.2	Line inversion (driving scheme A) and frame inversion (driving scheme B)	10	18	Handling information	41
8.3	Starting and resetting the PCF8551	11	19	Packing information	41
8.3.1	Power-down mode	11	19.1	Tape and reel information	41
8.3.2	Power-On Reset (POR)	11	20	Soldering of SMD packages	41
8.3.3	Command: Software_reset	11	20.1	Introduction to soldering	41
8.4	Display data register mapping	12	20.2	Wave and reflow soldering	41
9	Possible display configurations	14	20.3	Wave soldering	42
9.1	LCD bias generator	16	20.4	Reflow soldering	42
9.2	LCD voltage selector	16	21	Footprint information	44
9.2.1	Electro-optical performance	17	22	Appendix	45
9.2.2	LCD drive mode waveforms	19	22.1	LCD segment driver selection	45
9.2.2.1	Static drive mode	19	23	Abbreviations	47
9.2.2.2	1:2 Multiplex drive mode	20	24	References	48
9.2.2.3	1:3 Multiplex drive mode	22	25	Revision history	49
9.2.2.4	1:4 Multiplex drive mode	23	26	Legal information	50
9.3	Backplane and segment outputs	24	26.1	Data sheet status	50
9.3.1	Backplane outputs	24	26.2	Definitions	50
9.3.2	Segment outputs	24	26.3	Disclaimers	50
10	Power Sequencing	25	26.4	Trademarks	51
10.1	Power-on	25	27	Contact information	51
10.2	Power-off	25	28	Tables	52
10.3	Power sequences	25	29	Figures	53
11	Bus interfaces	26	30	Contents	54
11.1	I ² C-bus interface of the PCF8551A	26			
11.1.1	Bit transfer	26			

Please be aware that important notices concerning this document and the product(s) described herein, have been included in section 'Legal information'.

© NXP Semiconductors N.V. 2015.

All rights reserved.

For more information, please visit: <http://www.nxp.com>

For sales office addresses, please send an email to: salesaddresses@nxp.com

Date of release: 16 February 2015

Document identifier: PCF8551