

## SPECIFICATION SHEET

Assembly Part Number:  
**2501-1960-100**

### Reed Specifications

Physical		Operating		Electrical	
Configuration*	SPST	Pull in (+/- 2AT)*	35 - 40	AC Contact Rating	60 VA
Form*	A	Drop out*	15	DC Switching Voltage	400 VDC
Contact Position	CENTER	Operate Time	2.50 ms	AC Switching Voltage	400 VAC
Glass L	24.50 mm	Bounce Time	0.50 ms	DC Switching Current	3.00 A
Glass D	3.80 mm	Release Time	0.10 ms	AC Switching Current	3.00 A
Total L*	55.00 mm	Resonant Frequency	2400 Hz	DC Max Carry Current	4.00 A
Wire D	0.80 mm	Max Operating Frequency	200 Hz	AC Max Carry Current	4.00 A
Gap Location	CENTER	Operating Temperature Range	-40 - 105 °C	Min Breakdown Voltage	1000 VDC
Mount Spec*	THRU	Storage Temperature	N/A °C	Max Initial Contact Resistance	80 mOhm
Contact Material	RHODIUM	DC Contact Rating	60 W	Typical Initial Contact Resistance	N/A mOhm
Max Vibration Resistance	35 G	AC Contact Rating	60 VA	Max Contact Capacitance	0.50 pF
Max Shock Resistance (11 ms)	50 G	DC Switching Voltage	400 VDC	Min Insulation Resistance	10 <sup>11</sup> Ohm
Lead Tensile Strength	N/A KG	AC Switching Voltage	400 VAC		

\* Pre-processed, bare reed element

DIA 0.375" [9.525mm]  
 3/8 - 27 THREAD

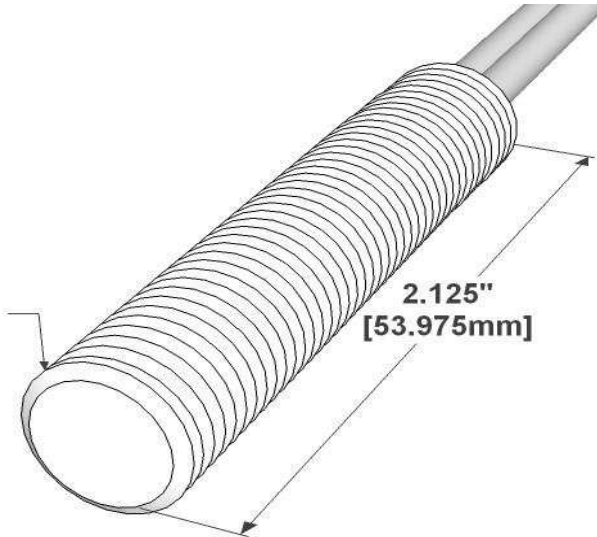

### Assembly Characteristics

Housing	2501
Housing Material	ANODIZED AL (T6/6061)
Reed	1960
Configuration	SPST
Form	A

### Wire/Cable Characteristics

Type	WIRE
Length	18.0/457.2 in/mm
Conductor Count	2
Colors	BLK
Insulation Material & Description	PVC
Gauge	22 AWG
Stranded Copper	7 STR
Maximum temperature	105 °C

### Standard Actuator/Minimum Make Distance

2501-4932-000 - NEO 30 - Cylinder	.44/11.18 in/mm
-----------------------------------	-----------------

### Assembly Certifications

UL RECOGNIZED (File #: E102207)	Y
RoHS	Y

For More Information Visit:  
[www.reedswitchdevelopments.com](http://www.reedswitchdevelopments.com)

Or Call Us At:  
 262-883-9060

IT SHALL BE THE RESPONSIBILITY OF THE BUYER TO ENSURE THAT THE GOODS ARE SUFFICIENT AND SUITABLE FOR THE PURPOSE OR PURPOSES INTENDED (WHETHER BY THE BUYER OR BY ANY THIRD PARTY) AND THAT THEIR CAPACITY AND PERFORMANCE IS NOT ADVERSELY AFFECTED BY ANY ITEMS USED IN THEIR INSTALLATION (WHERE RELEVANT) AND/OR IN CONNECTION WITH THEM.