



SAA1029

UNIVERSAL INDUSTRIAL LOGIC AND INTERFACE CIRCUIT

GENERAL DESCRIPTION

The SAA1029 is a universal bipolar logic and interface IC with high noise immunity and operational stability for industrial control applications. The most fundamental industrial control functions can be accomplished with only one SAA1029 IC.

MAIN ADVANTAGES

- **Simple realization of the basic industrial control functions (logic functions, timing functions, memory functions).**
- **High dynamic and static noise immunity.**
- **High operation stability.**
- **Short-circuit protection of inputs and outputs to both VEE and VCC.**
- **Wide interruption results in a safe input LOW state.**
- **LOC MOS (CMOS) compatible.**
- **Ideal applicaion for control loop such as emergency push button.**
- **Wide input range from 0 to 31.2 V.**
- **Adjustable output voltage range from 0 to 30 V.**
- **Wide supply voltage range from 14 to 31.2 V.**

The IC comprises,

- (1) Gate 1 : 4-input AND gate with 1 inverted input,
- (2) Gate 2 : 3-input AND gate with 1 inverted input and ajustable propagation delay,
- (3) Gate 3 : 2-input AND gate with 1 inverted input.

The SAA1029 can be used as direct interface with LOC MOS (CMOS) ICs for realizing more complex functions. Therefore, the output signal can be limited to the voltage level of the common output clamping pin Z.

The propagation delay of NAND gate 2 is adjustable from microseconds to seconds by using an external capacitor at pin 7 (pin C). This makes it possible to adapt the control frequency limits to the system, so the optimum dynamic noise immunity can be achieved.

All the static and dynamic circuit values (including the output voltage) are independent of the supply voltage over a wide operating range. This allows the use of a simple unstabilized power supply.

The output is held to the LOW state automatically during swithching on the power supply, so a special reset pulse can be omitted.

SAA1029

QUICK REFERENCE DATA

Supply voltage range	V_{CC}	14 to 31,2V
Operating ambient temperature range	T_{amb}	-30 to +85°C
Input voltage HIGH	V_{IH}	6,5 to 44V
Output voltage HIGH (without clamping)	V_{OH}	13 to 30V
Output voltage HIGH (without clamping at pin Z)	V_{OH}	2,0 to ($V_{CC} - 0,7$)V
Input current	I_I	max. 10mA
Quiescent supply current	I_{CC}	typ. 6,5mA

PACKAGE OUTLINE

16-lead DIL ; plastic (SOT38).

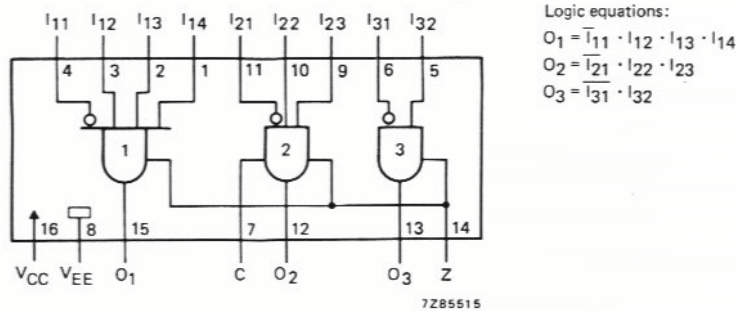

Fig. 1 Logic diagram.

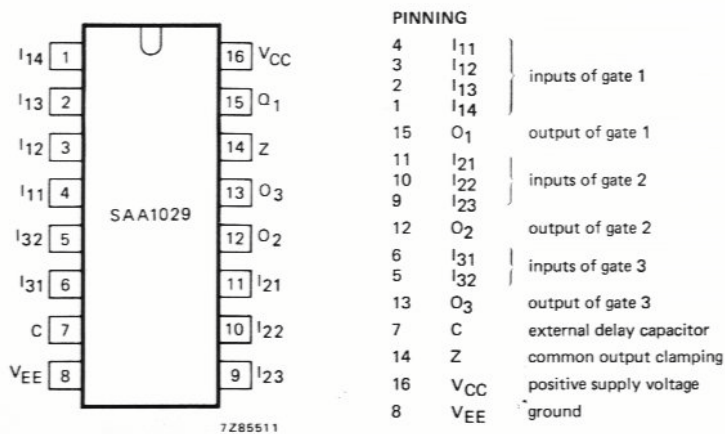

Fig. 2 Pinning diagram.

SAA1029

CHARACTERISTICS : At Tamb : -30 to +85°C/ Vcc 14V to 31,2V

PARAMETER	CONDITIONS	SYMB	MIN	TYP	MAX	UNIT	
SUPPLY VOLTAGE		V _{CC}	14	-	31,2	V	
OUTPUT CLAMPING VOLTAGE	V _Z =V _{CC} -1V	V _Z	-	-	30	V	
INPUT VOLTAGE LOW		V _{IL}	-	-	5	V	
INPUT VOLTAGE HIGH		V _{IH}	6,5	-	-	V	
CURRENT CONSUMPTION	V _{CC} :31V ; T _{amb} :25°C	I _{CC}	-	6,5	12,2	mA	
INPUT CURRENT HIGH	V _{CC} :24V ; T _{amb} :25°C	I _{IH}	0,3	-	-	mA	
INPUT CURRENT LOW	V _{CC} :24V ; T _{amb} :25°C	-I _{IL}	-	-	0,1	mA	
OUTPUT VOLTAGE WITHOUT CLAMPING HIGH (Pin 14 open)	V _{CC} :24V -I _o :5 mA	V _{OH}	V _{CC} -1,4V	-	-	V	
OUTPUT VOLTAGE WITHOUT CLAMPING LOW (Pin 14 open)	V _{CC} :24V	I _o :1,32 mA	V _{OL}	-	-	1	V
		I _o :2,91 mA	V _{OL}	-	-	1,5	V
OUTPUT VOLTAGE WITHOUT CLAMPING LOW (Pin 14 =V _Z)	V _{CC} :31,2V V _Z < V _{CC} -1V	I _o :1,32 mA	V _{OL}	-	-	1	V
		I _o :1,91 mA	V _{OL}	-	-	1,5	V
OUTPUT VOLTAGE WITHOUT CLAMPING HIGH (Pin 14 =V _Z)	V _Z < V _{CC} -1V	I _o :0 mA	V _{OH}	V _Z -0,475	-	V _Z +0,225	V
		-I _o :1 mA	V _{OH}	V _Z -0,455	-	V _Z +0,12	V
		-I _o :3 mA	V _{OH}	V _Z -0,41	-	V _Z +0,055	V
OUTPUT SHORT-CIRCUIT CURRENT							
LOW SIGNAL	V _{CC} :24V ; T _{amb} :25°C	I _{0scL}	2,95	-	9,6	mA	
HIGH SIGNAL	V _{CC} :24V ; T _{amb} :25°C	-I _{0scH}	2,95	-	9,6	mA	
PROPAGATION DELAYS Tamb :25°C Vcc 24V							
GATE 2	HIGH TO LOW	C :47nF	t _{PHL}	1,85	-	5,2	ms
	LOW TO HIGH	C :47nF	t _{PLH}	7.5	-	14	ms
GATE 1,2,3	HIGH TO LOW	C :0nF	t _{PHL}	-	3,5	-	µs
	LOW TO HIGH	C :0nF	t _{PLH}	-	3,5	-	µs