

BFX89 – BFY90

WIDE BAND VHF/UHF AMPLIFIER

DESCRIPTION :

- SILICON PLANAR EPITAXIAL TRANSISTORS
- TO-72 METAL CASE
- VERY LOW NOISE

APPLICATIONS :

- TELECOMMUNICATIONS
- WIDE BAND UHF AMPLIFIER
- RADIO COMMUNICATIONS

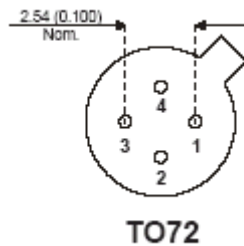

The BFX89 and BFY90 are silicon planar epitaxial NPN transistors produced using interdigitated base emitter geometry. They are particularly designed for use in wide band common-emitter linear amplifiers up to 1 GHz. They feature very high f_T , low reverse capacitance, excellent cross modulation properties and very low noise performance. The BFY90 is complementary to the BFR99A. Typical applications include telecommunication and radio communication equipment.

ABSOLUTE MAXIMUM RATINGS

Symbol	Ratings	Value	Unit
V_{CEO}	Collector-Emitter Voltage ($I_B = 0$)	15	V
V_{CER}	Collector-Emitter Voltage ($R_{BE} \leq 50\Omega$)	30	V
V_{CBO}	Collector-Base Voltage ($I_E = 0$)	30	V
V_{EBO}	Collector-Base Voltage ($I_C = 0$)	2.5	V
I_C	Collector Current	25	mA
I_{CM}	Collector Peak Current	50	mA
P_{tot}	Total Power Dissipation at $T_{amb} \leq 25\text{ }^\circ\text{C}$	200	mW
T_{stg}, T_j	Storage and Junction Temperature	-65 to 200	$^\circ\text{C}$



BFX89 – BFY90

THERMAL CHARACTERISTICS

Symbol	Ratings	Value	Unit	
R_{thJ-C}	Thermal Resistance, Junction – Case	Max	580	°C/W
R_{thJ-}	Thermal Resistance, Junction – ambient	Max	880	°C/W

ELECTRICAL CHARACTERISTICS

Tamb = 25°C unless otherwise specified

Symbol	Ratings	Test Condition(s)	Min	Typ	Max	Unit	
I_{CBO}	Collector Cutoff Current ($I_E=0$)	$V_{CB} = 15V$	-	-	10	nA	
V_{CEK}^*	Collector-emitter Knee Voltage	$I_C = 20mA$	-	-	0.75	V	
f_T	Transition Frequency	$V_{CE} = 5V$ $f = 500MHZ$ $I_C = 2 mA$	BFX89	-	1	-	GHz
			BFY90	1	1.1	-	
		$V_{CE} = 5V$ $f = 500MHZ$ $I_C = 25 mA$	BFX89	-	1.2	-	
			BFY90	1.3	1.4	-	
h_{FE}	DC Current Gain	$I_C = 2mA$ $V_{CE} = 1 V$	BFX89	20	-	150	-
			BFY90	25	-	150	
		$I_C = 25mA$ $V_{CE} = 1 V$	BFX89	20	-	125	
			BFY90	25	-	125	
$C_{CBO}(1)$	Collector-base Capacitance	$I_E = 0$ $V_{CB} = 10V$ $f = 1MHZ$ $V_{CE} = 5$	BFX89	-	-	1.7	pF
			BFY90	-	-	1.5	
$C_{re}(2)$	Reverse Capacitance	$I_C = 2mA$ $f = 1MHZ$	BFX89	-	0.6	-	pF
			BFY90	-	0.6	0.8	



BFX89 – BFY90

ELECTRICAL CHARACTERISTICS

Tamb = 25°C unless otherwise specified

Symbol	Ratings	Test Condition(s)	Min	Typ	Mx	Unit	
NF(2)	Noise Figure	I _C = 2mA , V _{CE} = 5 V f = 100KHz Rg = Optimized	BFY90 Only	-	-	4	dB
		I _C = 2mA , V _{CE} = 5 V f= 200 MHz Rg = Optimized	BFX89	-	3.3	4	
			BFY90	-	2.5	3.5	
		I _C = 2mA , V _{CE} = 5 V f = 500 MHz Rg = 50 Ω	BFX89	-	-	6.5	
			BFY90	-	-	5	
		I _C = 2mA , V _{CE} = 5 V f = 800 MHz Rg = Optimized	BFX89	-	7	-	
BFY90	-		5.5	-			
G_{pe} (2)	Power Gain (not neutralized)	For BFX89 I _C = 8mA V _{CE} = 10 V	f=200 MHz	19	22	-	dB
			f=800 MHz	-	7	-	
		For BFY90 I _C = 14mA V _{CE} = 10 V	f=200 MHz	21	23	-	
			f=800 MHz	-	8	-	
P_o	Output Power	For BFX89 I _C =8mA V _{CE} = 10 V D _{im} = -30 dB	(3) Channel 9	-	6	-	mW
			(4) Channel 62	-	6	-	
		For BFY90 I _C =14mA V _{CE} = 10 V D _{im} = -30 dB	(3) Channel 9	10	12	-	
			(4) Channel 62	-	12	-	

* I_B = value for which I_C =22 mA at V_{CE} = 1V

(1) Shield lead not grounded

(3) f_p = 202MHz, f_q = 205 MHz, f(2q-p) = 208MHz

(2) Shield lead grounded

(4) f_p = 798MHz, f_q = 802 MHz, f(2q-p) = 806MHz



BFX89 – BFY90

MECHANICAL DATA CASE TO-72

DIMENSIONS		
	mm	
	min	max
A	5.31	5.84
B	4.45	4.95
C	-	0.76
D	4.32	5.33
E	12.7	-
F	0.41	0.48
G	2.54	
H	1.27	
J	0.91	1.17
K	0.71	1.22

Pin 1 :	Emitter
Pin 2 :	Base
Pin 3 :	Collector
Pin 4 :	Case

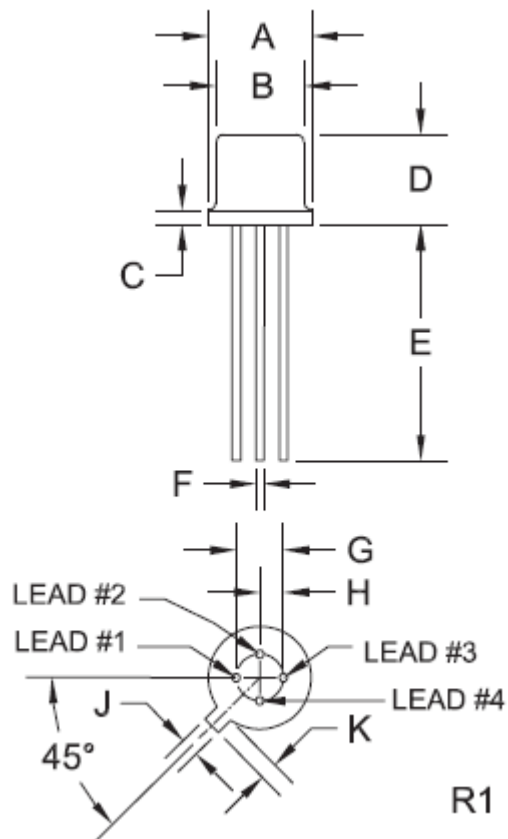

Revised August 2012

Information furnished is believed to be accurate and reliable. However, Comset Semiconductors assumes no responsibility for the consequences of use of such information nor for any infringement of patents or other rights of third parties which may result from its use. Data are subject to change without notice. Comset Semiconductors makes no warranty, representation or guarantee regarding the suitability of its products for any particular purpose, nor does Comset Semiconductors assume any liability arising out of the application or use of any product and specifically disclaims any and all liability, including without limitation consequential or incidental damages. Comset Semiconductors' products are not authorized for use as critical components in life support devices or systems.

www.comsetsemi.com

info@comsetsemi.com