

NPN BUX48 – BUX48A

HIGH VOLTAGE FAST-SWITCHING POWER TRANSISTOR

They are silicon multi-epitaxial mesa NPN transistor in Jedec TO-3 case.
They are intended for use in switching and industrial equipment.
Compliance to RoHS.

ABSOLUTE MAXIMUM RATINGS

Symbol	Ratings		Value	Unit	
V_{CEO}	Collector-Emitter Voltage	$I_B = 0$	BUX48	400	V
			BUX48A	450	
V_{CES}	Collector-Emitter Voltage	$V_{BE} = 0$	BUX48	850	V
			BUX48A	1000	
V_{CER}	Collector-Emitter Voltage	$R_{BE} = 10\Omega$	BUX48	850	
			BUX48A	1000	
V_{CBO}	Collector-Base Voltage	$I_E = 0$	BUX48	850	V
			BUX48A	1000	
V_{EBO}	Emitter-Base Voltage	$I_C = 0$		7	V
I_C	Collector Current			15	A
I_{CM}	Collector Current Peak	$t_p = 5ms$		30	A
I_B	Base Current			4	A
I_{BM}	Base Current Peak			20	A
P_t	Total Power Dissipation	@ $T_C = 25^\circ$		175	W
T_J	Junction Temperature			200	$^\circ C$
T_{Stg}	Storage Temperature			-65 to +200	$^\circ C$

THERMAL CHARACTERISTICS

Symbol	Ratings	Value	Unit
R_{thJC}	Thermal Resistance, Junction to Case	1	$^\circ C/W$

NPN BUX48 – BUX48A

ELECTRICAL CHARACTERISTICS

TC=25°C unless otherwise noted

Symbol	Ratings	Test Condition(s)		Min	Typ	Max	Unit		
$V_{CEO(SUS)}$	Collector-Emitter Sustaining Voltage (*)	$I_C = 100 \text{ mA}$	BUX48	400	-	-	V		
			BUX48A	450	-	-			
V_{EBO}	Emitter-Base Voltage	$I_C = 0$ $I_E = 50 \text{ mA}$	BUX48	7	-	30	V		
			BUX48A						
I_{CER}	Collector Cutoff Current	$V_{CE} = 400 \text{ V}$ $I_B = 0$ $R_{BE} = 10\Omega$	@ 25°C	BUX48	-	-	mA		
			@ 125°C					4	
		$V_{CE} = 450 \text{ V}$ $I_B = 0$ $R_{BE} = 10\Omega$	@ 25°C	BUX48A	-	-		0.5	
			@ 125°C						4
I_{CES}	Collector Cutoff Current	$V_{CE} = 850 \text{ V}$ $V_{BE} = 0$	@ 25°C	BUX48	-	-	mA		
			@ 125°C					0.2	
		$V_{CE} = 1000 \text{ V}$ $V_{BE} = 0$	@ 25°C	BUX48A	-	-		0.2	
			@ 125°C						2
I_{EBO}	Emitter Cutoff Current	$V_{EB} = 5 \text{ V}, I_C = 0$	BUX48	-	-	0.1	mA		
			BUX48A						
h_{FE}	DC Current Gain (*)	$I_C = 10 \text{ A}, V_{CE} = 5 \text{ V}$	BUX48	8	-	-	-		
		$I_C = 8 \text{ A}, V_{CE} = 5 \text{ V}$	BUX48A						
$V_{CE(SAT)}$	Collector-Emitter saturation Voltage (*)	$I_C = 10 \text{ A}, I_B = 2 \text{ A}$	BUX48	-	-	1.5	V		
		$I_C = 8 \text{ A}, I_B = 1.6 \text{ A}$	BUX48A						
		$I_C = 15 \text{ A}, I_B = 34 \text{ A}$	BUX48			-		-	5
		$I_C = 12 \text{ A}, I_B = 2.4 \text{ A}$	BUX48A						
$V_{BE(SAT)}$	Base-Emitter saturation Voltage (*)	$I_C = 10 \text{ A}, I_B = 2 \text{ A}$	BUX48	-	-	1.6	-		
		$I_C = 12 \text{ A}, I_B = 2.4 \text{ A}$	BUX48A						

SWITCHING TIMES

Symbol	Ratings	Test Condition(s)	Min	Typ	Max	Unit
t_{on}	Turn-on time	$I_C = 10 \text{ A}, I_{B1} = -I_{B2} = 2 \text{ A}$ $V_{CC} = 300 \text{ V}, V_{EB} = 5 \text{ V}$	-	-	0.9	μs
t_s	Storage time		-	-	2	
t_f	File time		-	-	0.4	
t_{on}	Turn-on time	$I_C = 8 \text{ A}, I_{B1} = -I_{B2} = 1.6 \text{ A}$ $V_{CC} = 300 \text{ V}, V_{EB} = 5 \text{ V}$	-	-	0.9	μs
t_s	Storage time		-	-	2	
t_f	File time		-	-	0.4	

(*) Pulse Duration = 300 μs , Duty Cycle $\leq 2\%$

NPN BUX48 – BUX48A

MECHANICAL DATA CASE TO-3

DIMENSIONS (mm)			
	min	typ	max
A	11	-	13.10
B	0.97	-	1.15
C	1.5	-	1.65
D	8.32	-	8.92
E	19	-	22
G	10.70	-	11.1
N	16.50	-	17.20
P	25	-	27,20
R	3.84	-	4.21
U	38.50	-	40.13
V	29.90	-	30.40

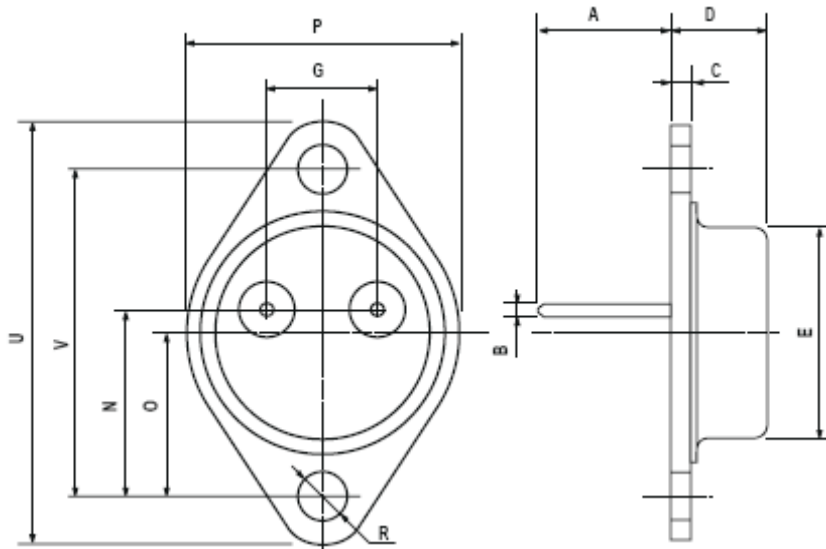

Pin 1 :	Base
Pin 2 :	Emitter
Case :	Collector

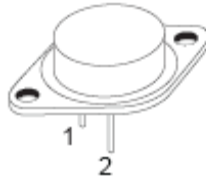

Revised October 2012

Information furnished is believed to be accurate and reliable. However, Comset Semiconductors assumes no responsibility for the consequences of use of such information nor for any infringement of patents or other rights of third parties which may results from its use. Data are subject to change without notice. Comset Semiconductors makes no warranty, representation or guarantee regarding the suitability of its products for any particular purpose, nor does Comset Semiconductors assume any liability arising out of the application or use of any product and specifically disclaims any and all liability, including without limitation consequential or incidental damages. Comset Semiconductors' products are not authorized for use as critical components in life support devices or systems.