



## NPN BDY53 – BDY54

### SILICON TRANSISTORS, DIFFUSED MESA

They are mounted in TO-3 metal package.  
 LF Large Signal Power Amplification  
 High Current Fast Switching  
 Compliance to RoHS.

#### ABSOLUTE MAXIMUM RATINGS

Symbol	Ratings		Value	Unit
$V_{CEO}$	Collector-Emitter Voltage	BDY53	60	V
		BDY54	120	
$V_{CBO}$	Collector-Base Voltage	BDY53	100	V
		BDY54	180	
$V_{EBO}$	Emitter-Base Voltage		7	V
$I_C$	Collector Current		12	A
$I_B$	Base Current		5	A
$P_{TOT}$	Power Dissipation	@ $T_C = 25^\circ$	60	W
$T_J$	Junction Temperature		-65 to +200	°C
$T_S$	Storage Temperature			

## NPN BDY53 – BDY54

### ELECTRICAL CHARACTERISTICS

TC=25°C unless otherwise noted

Symbol	Ratings	Test Condition(s)	Min	Typ	Max	Unit	
$V_{CEO(SUS)}$	Collector-Emitter Breakdown Voltage (*)	$I_C=100\text{ mA}, I_B=0$	BDY53	60	-	-	V
			BDY54	120	-	-	
$I_{EBO}$	Emitter-Base Cutoff Current	$V_{EB}=7\text{ V}$	BDY53	-	-	3.0	mA
			BDY54				
$I_{CEX}$	Collector-Emitter Cutoff Current	$V_{CE}=100\text{ V}$ $V_{BE}=-1.5\text{ V}$ $T_{CASE}=150^\circ\text{C}$	BDY53	-	-	15	mA
		$V_{CE}=150\text{ V}$ $V_{BE}=-1.5\text{ V}$ $T_{CASE}=150^\circ\text{C}$	BDY54	-	-		
$V_{CE(SAT)}$	Collector-Emitter saturation Voltage (*)	$I_C=4.0\text{ A}, I_B=0.4\text{ A}$	BDY53	-	-	1.1	V
		$I_C=7.0\text{ A}, I_B=1.4\text{ A}$	BDY54				
$V_{BE(SAT)}$	Base-Emitter Voltage (*)	$I_C=4.0\text{ A}, I_B=0.4\text{ A}$	BDY53	-	-	2	V
		$I_C=7.0\text{ A}, I_B=1.4\text{ A}$	BDY54				
$h_{21E}$	Static Forward Current transfer ratio (*)	$V_{CE}=1.5\text{ V}, I_C=2\text{ A}$	BDY53	20	-	60	V
			BDY54				
$f_T$	Transition Frequency	$V_{CE}=4.0\text{ V}, I_C=0.5\text{ A}$ $f=10\text{ MHz}$	BDY53	20	-	-	MHz
			BDY54				
$t_d + t_r$	Turn-on time	$I_C=5\text{ A}, I_B=1\text{ A}$	BDY53	-	0.3	-	$\mu\text{s}$
			BDY54				
$t_s + t_f$	Turn-off time	$I_C=5\text{ A}$ $I_{B1}=1\text{ A}$ $I_{B2}=-0.5\text{ A}$	BDY53	-	1.8	-	$\mu\text{s}$
			BDY54				

(\*) Pulse Width  $\approx 300\ \mu\text{s}$ , Duty Cycle  $\angle 2.0\%$

## NPN BDY53 – BDY54

### MECHANICAL DATA CASE TO-3

DIMENSIONS (mm)		
	min	max
A	11	13.10
B	0.97	1.15
C	1.5	1.65
D	8.32	8.92
F	19	20
G	10.70	11.1
N	16.50	17.20
P	25	26
R	4	4.09
U	38.50	39.30
V	30	30.30

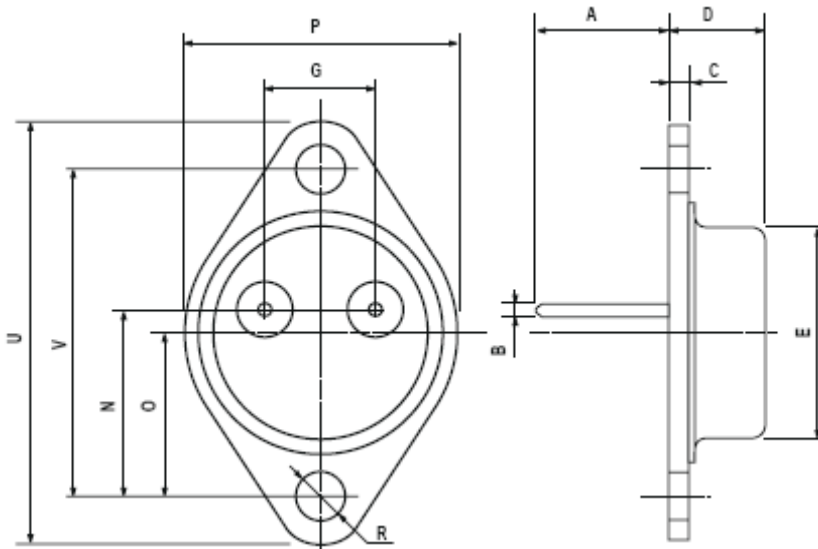

Pin 1 :	Base
Pin 2 :	Emitter
Case :	Collector

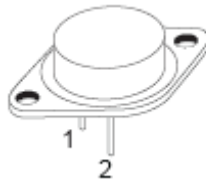

Revised October 2012

Information furnished is believed to be accurate and reliable. However, Comset Semiconductors assumes no responsibility for the consequences of use of such information nor for any infringement of patents or other rights of third parties which may result from its use. Data are subject to change without notice. Comset Semiconductors makes no warranty, representation or guarantee regarding the suitability of its products for any particular purpose, nor does Comset Semiconductors assume any liability arising out of the application or use of any product and specifically disclaims any and all liability, including without limitation consequential or incidental damages. Comset Semiconductors' products are not authorized for use as critical components in life support devices or systems.