



BDY26 – 183T2
BDY27 – 184T2
BDY28 – 185T2

NPN SILICON TRANSISTORS, DIFFUSED MESA.

They are NPN transistors mounted in Jedec TO-3.
 LF Large Signal Power Amplification.
 High Current Fast Switching.
 Compliance to RoHS.

ABSOLUTE MAXIMUM RATINGS

Symbol	Ratings	Value	Unit
V_{CEO}	Collector-Emitter Voltage	BDY26, 183T2	180
		BDY27, 184T2	200
		BDY28, 185T2	250
V_{CBO}	Collector-Base Voltage	BDY26, 183T2	300
		BDY27, 184T2	400
		BDY28, 185T2	500
V_{EBO}	Emitter-Base Voltage	10	V
I_C	Collector Current	6	A
I_B	Base Current	3	A
P_{TOT}	Power Dissipation @ $T_C = 25^\circ$	87.5	W
T_J	Junction Temperature	200	°C
T_S	Storage Temperature	-65 to +200	

THERMAL CHARACTERISTICS

Symbol	Ratings	Value	Unit
R_{thJ-C}	Thermal Resistance, Junction to Case	2	°C/W

BDY26 – 183T2
BDY27 – 184T2
BDY28 – 185T2

ELECTRICAL CHARACTERISTICS

TC=25°C unless otherwise noted

Symbol	Ratings	Test Condition(s)	Min	Typ	MAx	Unit	
$V_{CEO(BR)}$	Collector-Emitter Breakdown Voltage (*)	$I_C=50\text{ mA}$ $I_B=0$	BDY26, 183T2	180	-	-	V
			BDY27, 184T2	200	-	-	
			BDY28A, 185T2A	250	-	-	
			BDY28B, 185T2B	250	-	-	
			BDY28C, 185T2C	220	-	-	
$V_{(BR)CBO}$	Collector-Base Breakdown Voltage (*)	$I_C=3\text{ mA}$	BDY26, 183T2	300	-	-	V
			BDY27, 184T2	400	-	-	
			BDY28, 185T2	500	-	-	
I_{CEO}	Collector-Emitter Cutoff Current	$V_{CE}=180\text{ V}$	BDY26	-	-	1.0	mA
		$V_{CE}=200\text{ V}$	BDY27	-	-		
		$V_{CE}=250\text{ V}$	BDY28	-	-		
I_{EBO}	Emitter-Base Cutoff Current	$V_{EB}=10\text{ V}$	BDY26, 183T2 BDY27, 184T2 BDY28, 185T2	-	-	1.0	mA
I_{CES}	Collector-Emitter Cutoff Current	$V_{CE}=250\text{ V}$ $V_{BE}=0\text{ V}$	BDY26, 183T2	-	-	1.0	mA
		$V_{CE}=300\text{ V}$ $V_{BE}=0\text{ V}$	BDY27, 184T2	-	-		
		$V_{CE}=400\text{ V}$ $V_{BE}=0\text{ V}$	BDY28, 185T2	-	-		
$V_{CE(SAT)}$	Collector-Emitter saturation Voltage (*)	$I_C=2.0\text{ A}$ $I_B=0.25\text{ A}$	BDY26, 183T2	-	-	0.6	V
			BDY27, 184T2	-	-		
			BDY28, 185T2	-	-		
$V_{BE(SAT)}$	Base-Emitter saturation Voltage (*)	$I_C=2.0\text{ A}$ $I_B=0.25\text{ A}$	BDY26, 183T2	-	-	1.2	V
			BDY27, 184T2	-	-		
			BDY28, 185T2	-	-		
h_{FE}	DC Current Gain	$V_{CE}=4\text{ V}$ $I_C=1\text{ A}$	A	-	55	-	-
			B	-	65	-	
			C	-	90	-	
		$V_{CE}=4\text{ V}$ $I_C=2\text{ A}$	A	15	20	45	
			B	30	45	90	
			C	75	82	180	
f_T	Transition Frequency	$V_{CE}=15\text{ V}$, $I_C=0.5\text{ A}$, $f=10\text{ MHz}$	10	-	-	MHz	
$t_d + t_r$	Turn-on time	$I_C=5\text{ A}$, $I_B=1\text{ A}$	-	0.3	0.5	μs	
$t_s + t_f$	Turn-off time	$I_C=5\text{ A}$, $I_{B1}=1\text{ A}$, $I_{B2}=-0.5\text{ A}$	-	1.5	2.0	μs	

(*) Pulse Width $\approx 300\ \mu\text{s}$, Duty Cycle $\angle 2\%$



**BDY26 – 183T2
BDY27 – 184T2
BDY28 – 185T2**

MECHANICAL DATA CASE TO-3

DIMENSIONS (mm)		
	min	max
A	11	13.10
B	0.97	1.15
C	1.5	1.65
D	8.32	8.92
F	19	20
G	10.70	11.1
N	16.50	17.20
P	25	26
R	4	4.09
U	38.50	39.30
V	30	30.30

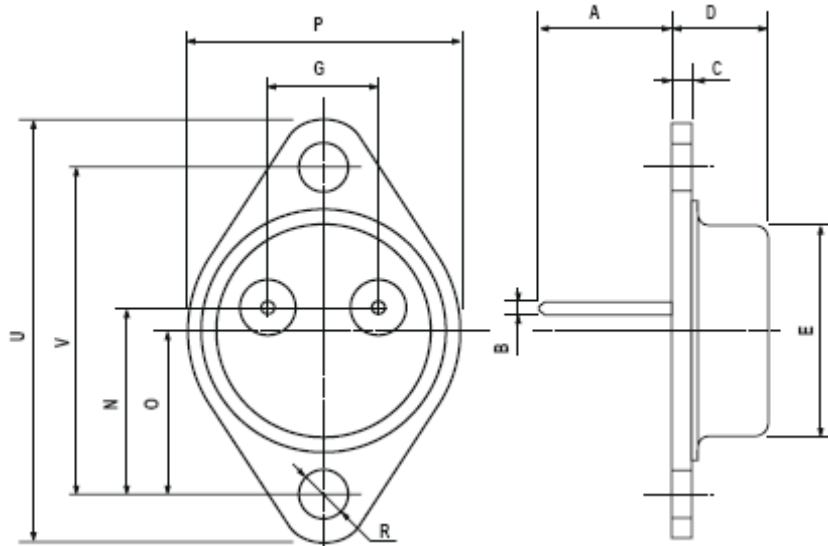

Pin 1 :	Base
Pin 2 :	Emitter
Case :	Collector

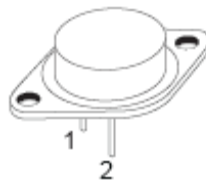

Revised August 2012

Information furnished is believed to be accurate and reliable. However, Comset Semiconductors assumes no responsibility for the consequences of use of such information nor for any infringement of patents or other rights of third parties which may result from its use. Data are subject to change without notice. Comset Semiconductors makes no warranty, representation or guarantee regarding the suitability of its products for any particular purpose, nor does Comset Semiconductors assume any liability arising out of the application or use of any product and specifically disclaims any and all liability, including without limitation consequential or incidental damages. Comset Semiconductors' products are not authorized for use as critical components in life support devices or systems.