



PNP BD202 – BD204

SILICON EPITAXIAL-BASE POWER TRANSISTORS

The BD202 and BD204 are PNP transistors mounted in Jedec TO-220 plastic package. They are primarily intended for use in hi-fi equipment delivering an output of 15 to 25 W into 4Ω or 8Ω load.

NPN complements are BD201 and BD203

Compliance to RoHS.

ABSOLUTE MAXIMUM RATINGS

Symbol	Ratings		Value	Unit
-V _{CEO}	Collector-Emitter Voltage	BD202	45	V
		BD204	60	
-V _{CBO}	Collector-Base Voltage	BD202	60	V
		BD204	60	
-V _{EBO}	Emitter-Base Voltage		5.0	V
-I _C	Collector Current	-I _C	8	A
		-I _{CM}	12	A
-I _{CSM}	Collector Current (non-repetitive peak value, t _p max. 2 ms)		25	A
-I _B	Base Current		3	A
P _D	Total Device Dissipation	@ T _C = 25°	60	W
T _J	<i>Junction Temperature</i>		150	°C
T _{Stg}	Storage Temperature range		-65 to +200	°C

THERMAL CHARACTERISTICS

Symbol	Ratings	Value	Unit
R _{thJ-a}	Thermal Resistance, Junction to mounting base	70	K/W
R _{thJ-mb}	Thermal Resistance, Junction to ambient in free air	2.08	K/W

PNP BD202 – BD204

ELECTRICAL CHARACTERISTICS

TC=25°C unless otherwise noted

Symbol	Ratings	Test Condition(s)	Min	Typ	Max	Unit	
$-I_{CEO}$	Collector Cutoff Current	$-V_{CE}=30\text{ V}, I_B=0\text{ V}$	BD202	-	-	0.2	mA
			BD204				
$-I_{CBO}$	Collector Cutoff Current	$-V_{CB}=40\text{ V}, I_E=0\text{ V}$ $T_j=150^\circ\text{C}$	BD202	-	-	1	mA
			BD204				
$-I_{EBO}$	Emitter Cutoff Current	$-V_{BE}=5\text{ V}, I_C=0$	BD202	-	-	0.5	mA
			BD204				
$-V_{CBO}$	Collector-Base Breakdown Voltage	$-I_C=1\text{ mA}, I_E=0$	BD202	60	-	-	V
			BD204				
$-V_{CEO}$	Collector Emitter Breakdown Voltage (*)	$-I_C=200\text{ mA}, I_B=0$	BD202	45	-	-	V
			BD204				
$-V_{EBO}$	Emitter Base Breakdown Voltage	$-I_E=1\text{ mA}, I_C=0$	BD202	5	-	-	V
			BD204				
$-V_{CE(SAT)}$	Collector-Emitter saturation Voltage (*)	$-I_C=3\text{ A}, -I_B=300\text{ mA}$	BD202	-	-	1	V
			BD204				
		$-I_C=6\text{ A}, -I_B=600\text{ mA}$	BD202	-	-	1.5	
			BD204				
$-V_{BE(SAT)}$	Base-Emitter saturation Voltage (*)	$-I_C=6\text{ A}, -I_B=600\text{ mA}$	BD202	-	-	2	V
			BD204				
$-V_{BE}$	Base Emitter Voltage (*)	$-I_C=3\text{ A}, -V_{CE}=2\text{ V}$	BD202	-	-	1.5	V
			BD204				
h_{FE}	DC Current Gain (*)	$-I_C=3\text{ A}, -V_{CE}=2\text{ V}$	BD202	30	-	-	-
		$-I_C=2\text{ A}, -V_{CE}=2\text{ V}$	BD204				
f_{hfe}	Cut-off frequency	$-I_C=300\text{ mA}$ $-V_{CE}=3\text{ V}$	BD202	25	-	-	KHz
			BD204				
f_T	Transition frequency	$-I_C=300\text{ mA}$ $-V_{CE}=3\text{ V}$ $f=1\text{ MHz}$	BD202	7	-	-	MHz
			BD204				
$I_{s/b}$	Forward bias second breakdown collector current	$-V_{CE}=40\text{ V}, t_p=0.1\text{ s}$ $T_{amb}=25^\circ\text{C}$	BD202	1.5	-	-	A
			BD204				
h_{FE1}/h_{FE2}	DC current gain	$-I_C=1\text{ A}, V_{CE}=2\text{ V}$	BD202	2.5	-	-	-
			BD204				
t_{on}	Turn-on time	$-I_{Con}=2\text{ A}$ $-I_{Bon}=I_{Boff}=200\text{ mA}$	BD202	-	-	1	μs
T_{off}	Turn-off time		BD204				
			BD202				
			BD204				

(*) Pulse conditions : $t_p < 300\ \mu\text{s}, \delta = 2\%$

PNP BD202 – BD204

MECHANICAL DATA CASE TO-220

DIMENSIONS (mm)		
	Min.	Max.
A	9,90	10,30
B	15,65	15,90
C	13,20	13,40
D	6,45	6,65
E	4,30	4,50
F	2,70	3,15
G	2,60	3,00
H	15,75	17,15
L	1,15	1,40
M	3,50	3,70
N	-	1,37
P	0,46	0,55
R	2,50	2,70
S	4,98	5,08
T	2,49	2,54
U	0,70	0,90

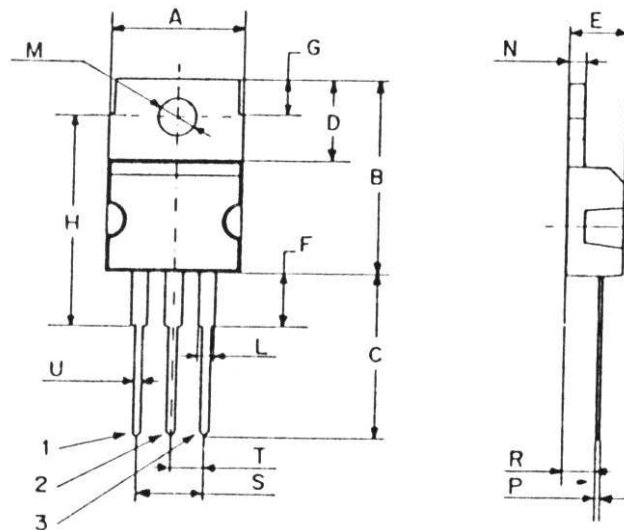

Pin 1 :	Base
Pin 2 :	Collector
Pin 3 :	Emitter
Case :	Collector

Revised September 2012

Information furnished is believed to be accurate and reliable. However, Comset Semiconductors assumes no responsibility for the consequences of use of such information nor for any infringement of patents or other rights of third parties which may result from its use. Data are subject to change without notice. Comset Semiconductors makes no warranty, representation or guarantee regarding the suitability of its products for any particular purpose, nor does Comset Semiconductors assume any liability arising out of the application or use of any product and specifically disclaims any and all liability, including without limitation consequential or incidental damages. Comset Semiconductors' products are not authorized for use as critical components in life support devices or systems.