

## MSS40 / MSS50 Series

### BACK TO BACK SCR MODULE

The MSS40 / MSS50 Series is based on two back-to-back SCR configurations, providing high noise immunity. They are suitable for high power applications. The compactness of the SOT-227 package allows high power density and optimized power bus connections. Compliance to RoHS.



SOT-227

#### MAIN FEATURES

- $I_{T(RMS)}$  : 55 and 70 A
- $V_{DRM}/V_{RRM}$  : 800 and 1200 V
- $I_{GT}$  : 50 mA

- 1 : Thyristor 2 Anode (A2)
- 2 : Thyristor 2 Gate (G2)
- 3 : Thyristor 1 Anode (A1)
- 4 : Thyristor 1 Gate (G1)

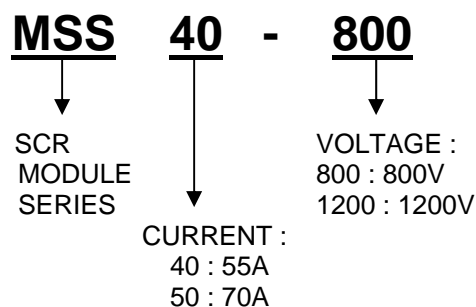
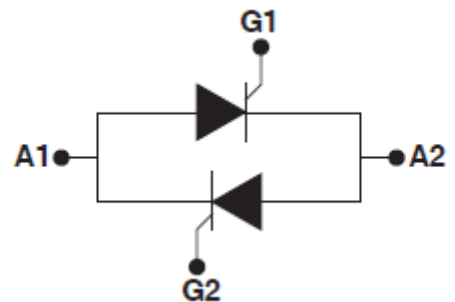
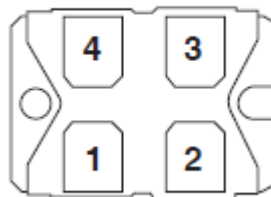

## MSS40 / MSS50 Series

### ABSOLUTE MAXIMUM RATINGS

Symbol	Ratings			Value		Unit
				MSS40	MSS50	
$I_{T(RMS)}$	RMS on-state current		$T_C = 80\text{ }^\circ\text{C}$	55	-	A
			$T_C = 85\text{ }^\circ\text{C}$	-	70	
$I_{TSM}$	Non repetitive surge peak on-state current	$t_p = 16.7\text{ms}$ $t_p = 20\text{ms}$	$T_j = 25\text{ }^\circ\text{C}$	420	630	A
				400	600	
$I^2t$	$I^2t$ Value for fusing	$t_p = 10\text{ms}$	$T_j = 25\text{ }^\circ\text{C}$	800	1800	$\text{A}^2\text{s}$
$DI/dt$	Critical rate of rise of on-state current $I_G = 2I_{GT}$ , $t_r \leq 100\text{ns}$	$F = 120\text{Hz}$	$T_j = 125\text{ }^\circ\text{C}$	50		$\text{A}/\mu\text{s}$
$I_{GM}$	Peak gate current	$t_p = 20\mu\text{s}$	$T_j = 125\text{ }^\circ\text{C}$	4		A
$P_{G(AV)}$	Average gate power dissipation		$T_j = 125\text{ }^\circ\text{C}$	1		W
$T_j$	Operating junction temperature range			-40 to +125		$^\circ\text{C}$
$T_{stg}$	Storage junction temperature range			-40 to +150		
$V_{RGM}$	Maximum peak reverse gate voltage			5		V

### THERMAL CHARACTERISTICS

Symbol	Ratings		Value	Unit	
$R_{th(j-c)}$	Junction to case (AC)		MSS40	0.6	$^\circ\text{C}/\text{W}$
			MSS50	0.45	

## MSS40 / MSS50 Series

### ELECTRICAL CHARACTERISTICS

TC=25°C unless otherwise noted

Symbol	Test Conditions		Min	Typ	Max	Unit	
$I_{DRM}$	$V_{DRM} = V_{DRM} \text{ Rated}$	$T_j = 25\text{ }^\circ\text{C}$	MSS40	-	-	20	$\mu\text{A}$
			MSS50	-	-	20	$\mu\text{A}$
		$T_j = 125\text{ }^\circ\text{C}$	MSS40	-	-	10	mA
			MSS50	-	-	10	mA
$I_{RRM}$	$V_{RRM} = V_{RRM} \text{ Rated}$	$T_j = 25\text{ }^\circ\text{C}$	MSS40	-	-	20	$\mu\text{A}$
			MSS50	-	-	20	$\mu\text{A}$
		$T_j = 125\text{ }^\circ\text{C}$	MSS40	-	-	10	mA
			MSS50	-	-	10	mA
$I_{GT}$	$V_D = 12\text{ V}, R_L = 33\text{ }\Omega$		MSS40	5	-	50	mA
			MSS50	5	-	50	mA
$V_{GT}$	$V_D = 12\text{ V}, R_L = 33\text{ }\Omega$		MSS40	-	-	1.3	V
			MSS50	-	-	1.3	V
$V_{GD}$	$V_D = V_{DRM}, R_L = 3.3\text{ k}\Omega$	$T_j = 125\text{ }^\circ\text{C}$	MSS40	0.2	-	-	V
			MSS50	0.2	-	-	V
$I_H$	$I_T = 500\text{ mA}$ Gate open		MSS40	-	-	80	mA
			MSS50	-	-	80	mA
$V_{TM}$	$I_{TM} = 80\text{ A}$ $t_p = 380\text{ }\mu\text{s}$	$T_j = 25\text{ }^\circ\text{C}$	MSS40	-	-	1.7	V
	$I_{TM} = 100\text{ A}$ $t_p = 380\text{ }\mu\text{s}$		MSS50	-	-	1.7	
$I_L$	$I_G = 1.2 \times I_{GT}$		MSS40	-	-	120	mA
			MSS50	-	-	120	mA
$dV/dt$	$V_D = 67\% V_{DRM}$ Gate open	$T_j = 125\text{ }^\circ\text{C}$	MSS40	1000	-	-	V/ $\mu\text{s}$
			MSS50	1000	-	-	
$V_{t0}$	Threshold voltage	$T_j = 125\text{ }^\circ\text{C}$	MSS40	-	-	0.85	V
			MSS50	-	-	0.85	
$R_d$	Dynamic resistance	$T_j = 125\text{ }^\circ\text{C}$	MSS40	-	-	11	m $\Omega$
			MSS50	-	-	7	

## MSS40 / MSS50 Series

### MECHANICAL DATA CASE SOT-227

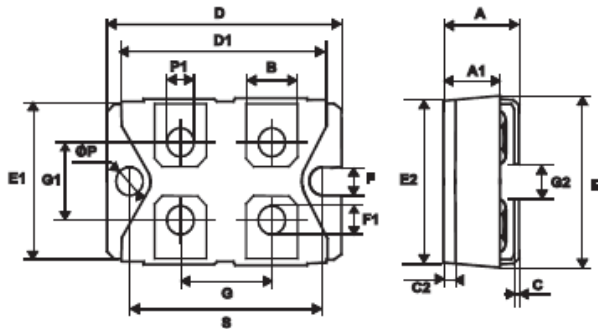

REF.	DIMENSIONS			
	Millimeters		Inches	
	Min.	Max.	Min.	Max.
A	11.80	12.20	0.465	0.480
A1	8.90	9.10	0.350	0.358
B	7.8	8.20	0.307	0.323
C	0.75	0.85	0.030	0.033
C2	1.95	2.05	0.077	0.081
D	37.80	38.20	1.488	1.504
D1	31.50	31.70	1.240	1.248
E	25.15	25.50	0.990	1.004
E1	23.85	24.15	0.939	0.951
E2	24.80 typ.		0.976 typ.	
G	14.90	15.10	0.587	0.594
G1	12.60	12.80	0.496	0.504
G2	3.50	4.30	0.138	0.169
F	4.10	4.30	0.161	0.169
F1	4.60	5.00	0.181	0.197
P	4.00	4.30	0.157	0.69
P1	4.00	4.40	0.157	0.173
S	30.10	30.30	1.185	1.193

Revised September 2012

Information furnished is believed to be accurate and reliable. However, Comset Semiconductors assumes no responsibility for the consequences of use of such information nor for any infringement of patents or other rights of third parties which may result from its use. Data are subject to change without notice. Comset Semiconductors makes no warranty, representation or guarantee regarding the suitability of its products for any particular purpose, nor does Comset Semiconductors assume any liability arising out of the application or use of any product and specifically disclaims any and all liability, including without limitation consequential or incidental damages. Comset Semiconductors' products are not authorized for use as critical components in life support devices or systems.