



## NPN BFW16A

### HF WIDEBAND TRANSISTORS

The BFW16A is NPN multi-emitter transistor in a TO-39 metal envelope, with the collector connected to the case. The transistor has extremely good intermodulation properties and a high power gain. It is a ruggedized version of the BFW16, which it succeeds.

It is primarily intended for :

- Final and driver stages of channel and band aerial amplifiers with high output power for bands I , II , III , IV , V (40-860 MHz).
  - Final stage of the wideband vertical amplifier in high speed oscilloscopes.
- Compliance to RoHS.

#### ABSOLUTE MAXIMUM RATINGS

Symbol	Ratings		Value	Unit
V <sub>CEO</sub>	Collector-Emitter Voltage	I <sub>B</sub> = 0	25	V
V <sub>CBOM</sub>	Collector-Base Voltage (open emitter ; peak value)	I <sub>E</sub> = 0	40	V
V <sub>EBO</sub>	Emitter-Base Voltage	I <sub>C</sub> = 0	2	V
V <sub>CERM</sub>	Collector-Emitter Voltage	R <sub>BE</sub> ≤ 50Ω	40	V
I <sub>C</sub>	Collector Current		150	mA
I <sub>CM</sub>	Collector Peak Current		300	mA
P <sub>t</sub>	Total Power Dissipation	@ T <sub>C</sub> = 125°	1.5	W
T <sub>J</sub>	Junction Temperature		200	°C
T <sub>Stg</sub>	Storage Temperature		-65 to +200	°C

#### THERMAL CHARACTERISTICS

Symbol	Ratings		Value	Unit
R <sub>thJa</sub>	Thermal Resistance, Junction to Ambient		250	K/W
R <sub>thJmb</sub>	Thermal Resistance, Junction to Mounting Base		50	K/W
R <sub>thJmb-h</sub>	Thermal Resistance, Junction to Mounting Base to heatsink		1.2	K/W



## NPN BFW16A

### ELECTRICAL CHARACTERISTICS

TC=25°C unless otherwise noted

Symbol	Ratings	Test Condition(s)	Min	Typ	Max	Unit	
$I_{CB0}$	Collector Cutoff Current	$I_E=0, V_{CB}=20\text{ V}, T_J=150^\circ\text{C}$	-	-	20	$\mu\text{A}$	
$h_{FE}$	DC Current Gain	$I_C=50\text{ mA}, V_{CE}=5.0\text{ V}$	25	-	-	-	
		$I_C=150\text{ mA}, V_{CE}=5.0\text{ V}$	25	-	-		
$f_T$	Transition frequency	$V_{CE}=15\text{ V}, I_C=150\text{ mA}$ $f=500\text{ MHz}$	-	1.2	-	GHz	
$C_c$	Collector capacitance at $f=1\text{MHz}$	$I_E=I_e=0, V_{CB}=15\text{ V}$	-	-	4	pF	
$C_{re}$	Feedback capacitance at $f=1\text{MHz}$	$I_C=10\text{ mA}, V_{CE}=15\text{ V}$ $T_{amb}=25^\circ\text{C}$	-	1.7	-		
<b>F</b>	Noise figure at $f=200\text{ MHz}$	$I_C=30\text{ mA}, V_{CE}=15\text{ V}$ $Z_S=75\ \Omega, T_{amb}=25^\circ\text{C}$	-	-	6	dB	
<b>G<sub>P</sub></b>	Power gain (not neutralized)	$I_C=70\text{ mA}$ $V_{CE}=18\text{ V}$ $T_{amb}=25^\circ\text{C}$	200 MHz	-	16	-	dB
			800 MHz	-	6.5	-	



## NPN BFW16A

### MECHANICAL DATA CASE TO-39

DIMENSIONS (mm)		
	min	max
A	8.50	9.39
B	7.74	8.50
C	6.09	6.60
D	0.40	0.53
E	-	0.88
F	2.41	2.66
G	4.82	5.33
H	0.71	0.86
J	0.73	1.02
K	12.70	-
L	42°	48°

Pin 1 :	Emitter
Pin 2 :	Base
Pin 3 :	Collector
Case :	Collector

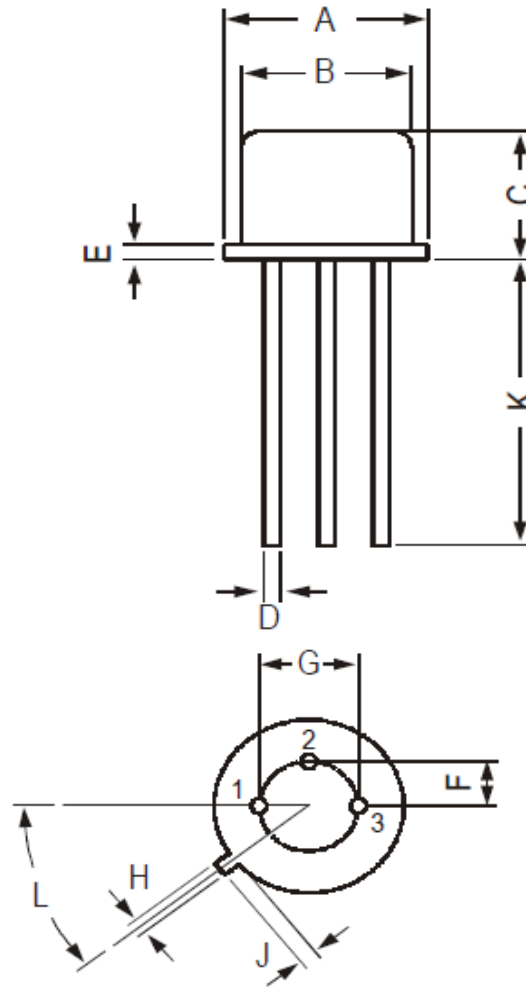

Revised September 2012

Information furnished is believed to be accurate and reliable. However, Comset Semiconductors assumes no responsibility for the consequences of use of such information nor for any infringement of patents or other rights of third parties which may results from its use. Data are subject to change without notice. Comset Semiconductors makes no warranty, representation or guarantee regarding the suitability of its products for any particular purpose, nor does Comset Semiconductors assume any liability arising out of the application or use of any product and specifically disclaims any and all liability, including without limitation consequential or incidental damages. Comset Semiconductors' products are not authorized for use as critical components in life support devices or systems.