



## BDV66-A-B-C

### PNP SILICON DARLINGTONS POWER TRANSISTORS

They are silicon epitaxial base transistors mounted in TO-3PN.  
 They are designed for audio output stages and general amplifier and switching applications.  
 complementary is BDV67-A-B-C  
 Compliance to RoHS.

#### ABSOLUTE MAXIMUM RATINGS

Symbol	Ratings		Value	Unit
$V_{CEO}$	Collector-Emitter Voltage	BDV66	-80	V
		BDV66A	-100	
		BDV66B	-120	
		BDV66C	-140	
$V_{CBO}$	Collector-Base Voltage	BDV66	-80	V
		BDV66A	-100	
		BDV66B	-120	
		BDV66C	-140	
$V_{EBO}$	Emitter-Base Voltage	BDV66	-5.0	V
		BDV66A		
		BDV66B		
		BDV66C		
$I_c$	Collector Current	BDV66	-16	A
		BDV66A		
		BDV66B		
		BDV66C		
$I_{CM}$	Collector Peak Current	BDV66	-20	A
		BDV66A		
		BDV66B		
		BDV66C		
$I_B$	Base Current	BDV66	-0.5	A
		BDV66A		
		BDV66B		
		BDV66C		



## BDV66-A-B-C

### ABSOLUTE MAXIMUM RATINGS

Symbol	Ratings		Value	Unit	
$P_T$	Power Dissipation	$T_{mb} = 25^\circ\text{C}$	BDV66	175	Watts
			BDV66A		
			BDV66B		
			BDV66C		
$T_J$	Junction Temperature		BDV66	150	$^\circ\text{C}$
			BDV66A		
			BDV66B		
			BDV66C		
$T_S$	Storage Temperature		BDV66	-65 to +150	$^\circ\text{C}$
			BDV66A		
			BDV66B		
			BDV66C		

### THERMAL CHARACTERISTICS

Symbol	Ratings	Value	Unit
$R_{thj-c}$	Thermal Resistance, Junction to Case	0.625	$^\circ\text{C} / \text{W}$

### SWITCHING TIMES

Symbol	Ratings	Test Condition(s)	Value			Unit
			Min	Typ	Max	
$t_{on}$	turn-on time	$I_C = 10 \text{ A}, V_{CC} = 12 \text{ V}$ $I_{B1} = -I_{B2} = 40 \text{ mA}$	-	1	-	$\mu\text{s}$
$t_{off}$	turn-off time		-	3.5	-	

(\*) Pulse Width  $\approx 300 \mu\text{s}$ , Duty Cycle  $\leq 1.5 \%$

## BDV66-A-B-C

### ELECTRICAL CHARACTERISTICS

TC=25°C unless otherwise noted

Symbol	Ratings	Test Condition(s)		Min	Typ	Max	Unit	
$I_{CEO}$	Collector Cutoff Current	$V_{CE} = -40\text{ V}, I_B = 0$	BDV66	-	-	-1	mA	
		$V_{CE} = -50\text{ V}, I_B = 0$	BDV66A					
		$V_{CE} = -60\text{ V}, I_B = 0$	BDV66B					
		$V_{CE} = -70\text{ V}, I_B = 0$	BDV66C					
$I_{EBO}$	Emitter Cutoff Current	$V_{BE} = -5\text{ V}, I_C = 0$	BDV66	-	-	-5	mA	
			BDV66A					
			BDV66B					
			BDV66C					
$I_{CBO}$	Collector Cutoff Current	$I_E = 0$ $T_j = 25^\circ\text{C}$	$V_{CB} = -80\text{ V}$	BDV66	-	-	-1	mA
			$V_{CB} = -100\text{ V}$	BDV66A				
			$V_{CB} = -120\text{ V}$	BDV66B				
			$V_{CB} = -140\text{ V}$	BDV66C				
		$I_E = 0$ $T_j = 150^\circ\text{C}$	$V_{CB} = -40\text{ V}$	BDV66	-	-	-5	
			$V_{CB} = -50\text{ V}$	BDV66A				
			$V_{CB} = -60\text{ V}$	BDV66B				
			$V_{CB} = -70\text{ V}$	BDV66C				
$V_{CEO}$	Collector-Emitter Breakdown Voltage (*)	$I_C = -100\text{ mA}, I_B = 0$	BDV66	-60	-	-	V	
			BDV66A	-80	-	-		
			BDV66B	-100	-	-		
			BDV66C	-120	-	-		
$h_{FE}$	DC Current Gain (*)	$V_{CE} = -3\text{ V}, I_C = -10\text{ A}$	BDV66	1000	-	-	-	
			BDV66A					
			BDV66B					
			BDV66C					
$V_{CE(SAT)}$	Collector-Emitter saturation Voltage (*)	$I_C = -10\text{ A}, I_B = -40\text{ mA}$	BDV66	-	-	-2	V	
			BDV66A					
			BDV66B					
			BDV66C					
$V_{BE}$	Base-Emitter Voltage(*)	$V_{CE} = -3\text{ V}, I_C = -10\text{ A}$	BDV66	-	-	-2,5	V	
			BDV66A					
			BDV66B					
			BDV66C					
$C_{OB}$	Output Capacitance	$V_{CB} = -10\text{ V}, I_E = 0$ $f_{test} = 1\text{ MHz}$	BDV66	-	300	-	pF	
			BDV66A					
			BDV66B					
			BDV66C					

## BDV66-A-B-C

### MECHANICAL DATA CASE TO3PN Non Isolated Plastic Package

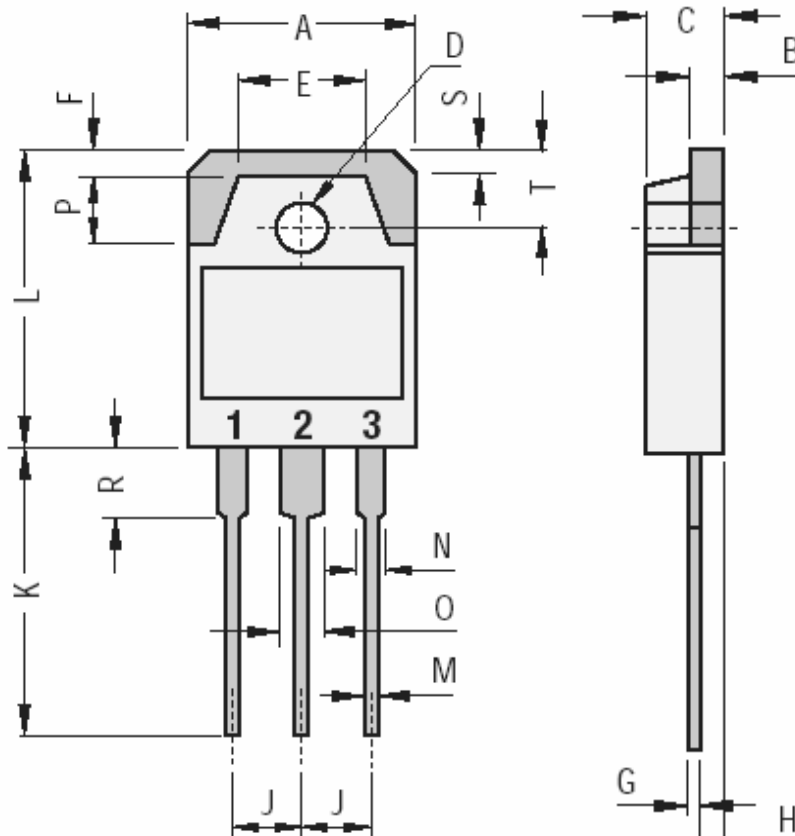

DIMENSIONS (mm)		
	Min.	Max.
A	15.20	1600
B	1.90	2.10
C	4.60	5.00
D	3.10	3.30
E		9.60
F		2.00
G	0.35	0.55
H		1.40
J	5.35	5.55
K	20.00	
L	19.60	20.20
M	0.95	1.25
N		2.00
O		3.00
P		4.00
R		4.00
S		1.80
T	4.80	5.20

Pin 1 :	Base
Pin 2 :	Collector
Pin 3 :	Emitter
Package	Collector

Revised August 2012

Information furnished is believed to be accurate and reliable. However, Comset Semiconductors assumes no responsibility for the consequences of use of such information nor for any infringement of patents or other rights of third parties which may result from its use. Data are subject to change without notice. Comset Semiconductors makes no warranty, representation or guarantee regarding the suitability of its products for any particular purpose, nor does Comset Semiconductors assume any liability arising out of the application or use of any product and specifically disclaims any and all liability, including without limitation consequential or incidental damages. Comset Semiconductors' products are not authorized for use as critical components in life support devices or systems.