

BDX64 – A – B – C

PNP SILICON DARLINGTON POWER TRANSISTOR

The BDX64, BDX64A, BDX64B and BDX64C are mounted in TO-3 metal package. High current power darlington designed for power amplification and switching applications. The complementary NPN are BDX65, BDX65A, BDX65B, BDX65C. Compliance to RoHS.

ABSOLUTE MAXIMUM RATINGS

Symbol	Ratings		Value	Unit	
V_{CEO}	Collector-Emitter Voltage		BDX64	-60	V
			BDX64A	-80	
			BDX64B	-100	
			BDX64C	-120	
V_{CEV}	Collector-Emitter Voltage	$V_{BE} = -1.5 \text{ V}$	BDX64	-60	V
			BDX64A	-80	
			BDX64B	-100	
			BDX64C	-120	
V_{EBO}	Emitter-Base Voltage		-5.0	V	
I_C	Collector Current		$I_{C(RMS)}$	-12	A
			I_{CM}	-16	
I_B	Base Current		0.2	A	
P_T	Power Dissipation	@ $T_C = 25^\circ$	117	W	
T_J	Junction Temperature		-55 to +200	°C	
T_S	Storage Temperature				

THERMAL CHARACTERISTICS

Symbol	Ratings	Value	Unit
R_{thJ-C}	Thermal Resistance, Junction to Case	1.5	°C/W

BDX64 – A – B – C

ELECTRICAL CHARACTERISTICS

TC=25°C unless otherwise noted

Symbol	Ratings	Test Condition(s)		Min	Typ	Max	Unit
$V_{CE(SUS)}$	Collector-Emitter Breakdown Voltage (*)	$I_C = -0.1\text{ A}$ $I_B = 0$ $L = 25\text{ mH}$	BDX64	-60	-	-	V
			BDX64A	-80	-	-	
			BDX64B	-100	-	-	
			BDX64C	-120	-	-	
I_{CEO}	Collector Cutoff Current	$V_{CE} = -30\text{ V}$ $V_{CE} = -40\text{ V}$ $V_{CE} = -50\text{ V}$ $V_{CE} = -60\text{ V}$	BDX64	-	-	-1.0	mA
			BDX64A	-	-		
			BDX64B	-	-		
			BDX64C	-	-		
I_{EBO}	Emitter Cutoff Current	$V_{BE} = -5\text{ V}$	BDX64	-	-	-5.0	mA
			BDX64A				
			BDX64B				
			BDX64C				
I_{CBO}	Collector-Base Cutoff Current	$V_{CBO} = -60\text{ V}$ $V_{CBO} = -40\text{ V}$ $T_{CASE} = 200^\circ\text{C}$ $V_{CBO} = -80\text{ V}$ $V_{CBO} = -50\text{ V}$ $T_{CASE} = 200^\circ\text{C}$ $V_{CBO} = -100\text{ V}$ $V_{CBO} = -60\text{ V}$ $T_{CASE} = 200^\circ\text{C}$ $V_{CBO} = -120\text{ V}$ $V_{CBO} = -70\text{ V}$ $T_{CASE} = 200^\circ$	BDX64	-	-	0.2	-
			BDX64	-	-	2	
			BDX64A	-	-	0.2	
			BDX64A	-	-	2	
			BDX64B	-	-	0.2	
			BDX64B	-	-	2	
			BDX64C	-	-	0.2	
			BDX64C	-	-	2	
$V_{CE(SAT)}$	Collector-Emitter saturation Voltage (*)	$I_C = -5.0\text{ A}$ $I_B = -20\text{ mA}$	BDX64	-	-	-2	V
			BDX64A				
			BDX64B				
			BDX64C				
V_F	Forward Voltage (pulse method)	$I_F = 5\text{ A}$	BDX64	-	1.8	-	V
			BDX64A				
			BDX64B				
			BDX64C				
V_{BE}	Base-Emitter Voltage (*)	$I_C = -5.0\text{ A}$ $V_{CE} = -3\text{ V}$	BDX64	-	-	-2.5	V
			BDX64A				
			BDX64B				
			BDX64C				

BDX64 – A – B – C

ELECTRICAL CHARACTERISTICS

TC=25°C unless otherwise noted

Symbol	Ratings	Test Condition(s)	Min	Typ	Max	Unit	
F_{hfe}	Cut-off frequency	- $V_{CE}=3$ V - $I_C=5$ A	BDX64	-	80	-	kHz
			BDX64A				
			BDX64B				
			BDX64C				
f_T	Transition Frequency	$V_{CE}=-3$ V $I_C=-5$ A $f=1$ MHz	BDX64	-	7	-	MHz
			BDX64A				
			BDX64B				
			BDX64C				
h_{FE}	D.C. current gain (*)	- $V_{CE}=-3$ V - $I_C=-1$ A	BDX64	-	1500	-	-
			BDX64A				
			BDX64B				
			BDX64C				
		- $V_{CE}=-3$ V - $I_C=-5$ A	BDX64	1000	-	-	
			BDX64A				
			BDX64B				
			BDX64C				
		- $V_{CE}=-3$ V - $I_C=-12$ A	BDX64	-	750	-	
			BDX64A				
			BDX64B				
			BDX64C				

(*) Pulse Width ≈ 300 μ s, Duty Cycle $\angle 2.0\%$

BDX64 – A – B – C

MECHANICAL DATA CASE TO-3

DIMENSIONS (mm)		
	min	max
A	11	13.10
B	0.97	1.15
C	1.5	1.65
D	8.32	8.92
F	19	20
G	10.70	11.1
N	16.50	17.20
P	25	26
R	4	4.09
U	38.50	39.30
V	30	30.30

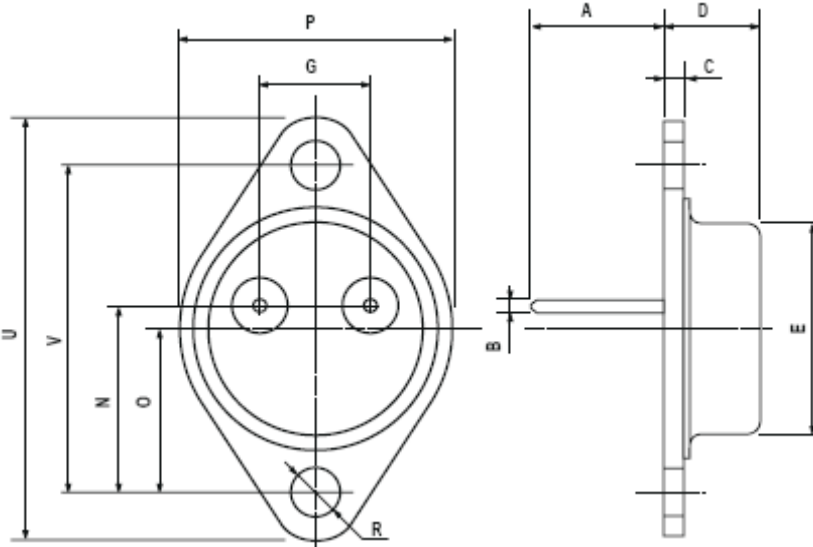

Pin 1 :	Base
Pin 2 :	Emitter
Case :	Collector

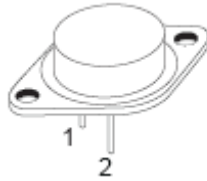

Revised September 2012

Information furnished is believed to be accurate and reliable. However, Comset Semiconductors assumes no responsibility for the consequences of use of such information nor for any infringement of patents or other rights of third parties which may result from its use. Data are subject to change without notice. Comset Semiconductors makes no warranty, representation or guarantee regarding the suitability of its products for any particular purpose, nor does Comset Semiconductors assume any liability arising out of the application or use of any product and specifically disclaims any and all liability, including without limitation consequential or incidental damages. Comset Semiconductors' products are not authorized for use as critical components in life support devices or systems.