



PNP MJ3000 – MJ3001

COMPLEMENTARY POWER DARLINGTONS

The MJ3000, and MJ3001 are silicon epitaxial-base PNP power transistors in monolithic Darlington configuration and are mounted in Jedec TO-3 metal case. They are intended for use in power linear and switching applications.

The complementary PNP types are the MJ2500 and MJ2501 respectively

Compliance to RoHS

ABSOLUTE MAXIMUM RATINGS

Symbol	Ratings		Value	Unit	
V_{CBO}	Collector-Base Voltage	$I_E=0$	MJ3000	60	V
			MJ3001	80	
V_{CEO}	Collector-Emitter Voltage	$I_B=0$	MJ3000	60	V
			MJ3001	80	
V_{EBO}	Emitter-Base Voltage	$I_C=0$	MJ3000	5.0	V
			MJ3001		
I_C	Collector Current		MJ3000	10	A
			MJ3001		
I_B	Base Current		MJ3000	0.2	A
			MJ3001		
P_T	Power Dissipation	@ $T_C < 25^\circ$	MJ3000 MJ3001	150	W
T_J	Junction Temperature		MJ3000	200	°C
T_s	Storage Temperature		MJ3001	-65 to +200	

THERMAL CHARACTERISTICS

Symbol	Ratings	Value	Unit
R_{thJ-C}	Thermal Resistance, Junction to Case	1.17	°C/W

PNP MJ3000 – MJ3001

ELECTRICAL CHARACTERISTICS

TC=25°C unless otherwise noted

Symbol	Ratings	Test Condition(s)	Min	Typ	Max	Unit		
BV_{CEO}	Collector-Emitter Breakdown Voltage (*)	I _C =100mA I _B =0	MJ3000 60	-	-	V		
			MJ3001 80	-	-			
I_{CEO}	Collector Cutoff Current	V _{CE} =30 V I _B =0	MJ3000	-	-	1.0	mA	
		V _{CE} =40 V I _B =0	MJ3001	-	-			
I_{EBO}	Emitter Cutoff Current	V _{BE} =5.0 V I _C =0	MJ3000 MJ3001	-	-	2.0	mA	
I_{CER}	Collector-Emitter Leakage Current	V _{CB} =60 V R _{BE} =1.0 kΩ	MJ3000	-	-	1.0	mA	
		V _{CB} =80 V R _{BE} =1.0 kΩ	MJ3001	-	-			
		V _{CB} =60 V R _{BE} =1.0 kΩ T _C =150°C	MJ3000	-	-	5.0		
		V _{CB} =80 V R _{BE} =1.0 kΩ T _C =150°C	MJ3001	-	-			
V_{CE(SAT)}	Collector-Emitter saturation Voltage (*)	I _C =5.0 A I _B =20 mA	MJ3000 MJ3001	-	-	2.0	V	
		I _C =10 A I _B =50 mA	MJ3000 MJ3001	-	-	4.0		
V_{BE}	Base-Emitter Voltage (*)	I _C =5.0 A V _{CE} =3.0V	MJ3000 MJ3001	-	-	3	V	
h_{FE}	DC Current Gain (*)	V _{CE} =3.0 V I _C =5.0 A	MJ3000 MJ3001	1000	-	-	-	

(*) Pulse Width ≈ 300 μs, Duty Cycle < 2.0%

PNP MJ3000 – MJ3001

MECHANICAL DATA CASE TO-3

DIMENSIONS (mm)		
	min	max
A	11	13.10
B	0.97	1.15
C	1.5	1.65
D	8.32	8.92
F	19	20
G	10.70	11.1
N	16.50	17.20
P	25	26
R	4	4.09
U	38.50	39.30
V	30	30.30

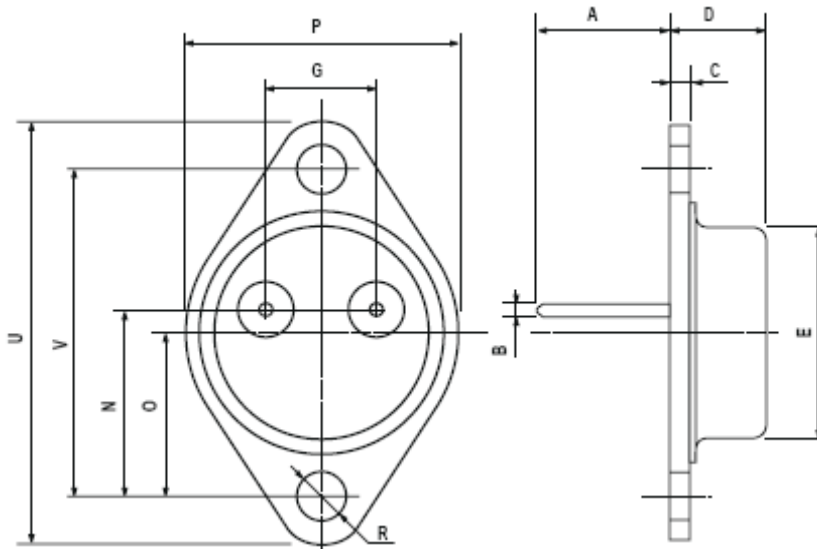

Pin 1 :	Base
Pin 2 :	Emitter
Case :	Collector

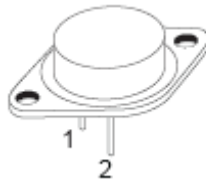

Revised September 2012

Information furnished is believed to be accurate and reliable. However, Comset Semiconductors assumes no responsibility for the consequences of use of such information nor for any infringement of patents or other rights of third parties which may result from its use. Data are subject to change without notice. Comset Semiconductors makes no warranty, representation or guarantee regarding the suitability of its products for any particular purpose, nor does Comset Semiconductors assume any liability arising out of the application or use of any product and specifically disclaims any and all liability, including without limitation consequential or incidental damages. Comset Semiconductors' products are not authorized for use as critical components in life support devices or systems.