



## BDX63 – A – B – C

### NPN SILICON DARLINGTON POWER TRANSISTOR

The BDX63, BDX63A, BDX63B and BDX63C are mounted in TO-3 metal package. High current power darlington transistors designed for power amplification and switching applications. The complementary PNP are BDX62, BDX62A, BDX62B, BDX62C. Compliance to RoHS.

#### ABSOLUTE MAXIMUM RATINGS

Symbol	Ratings		Value	Unit	
$V_{CEO}$	Collector-Emitter Voltage		BDX63	60	V
			BDX63A	80	
			BDX63B	100	
			BDX63C	120	
$V_{CEV}$	Collector-Emitter Voltage	$V_{BE} = -1.5\text{ V}$	BDX63	80	V
			BDX63A	100	
			BDX63B	120	
			BDX63C	140	
$V_{EBO}$	Emitter-Base Voltage		5.0	V	
$I_C$	Collector Current		$I_{C(RMS)}$	8	A
			$I_{CM}$	12	
$I_B$	Base Current		0.15	A	
$P_T$	Power Dissipation	@ $T_C = 25^\circ$	90	W	
$T_J$	Junction Temperature		-55 to +200	°C	
$T_S$	Storage Temperature				

#### THERMAL CHARACTERISTICS

Symbol	Ratings	Value	Unit
$R_{thJ-C}$	Thermal Resistance, Junction to Case	1.94	°C/W

## BDX63 – A – B – C

### ELECTRICAL CHARACTERISTICS

TC=25°C unless otherwise noted

Symbol	Ratings	Test Condition(s)		Min	Typ	Max	Unit	
$V_{CE(SUS)}$	Collector-Emitter Breakdown Voltage (*)	$I_C=0.1\text{ A}$ $I_B=0$ $L=25\text{mH}$	BDX63	60	-	-	V	
			BDX63A	80	-	-		
			BDX63B	100	-	-		
			BDX63C	120	-	-		
$I_{CEO}$	Collector Cutoff Current		$V_{CE}=30\text{ V}$	BDX63	-	-	0.5	mA
			$V_{CE}=40\text{ V}$	BDX63A	-	-		
			$V_{CE}=50\text{ V}$	BDX63B	-	-		
			$V_{CE}=60\text{ V}$	BDX63C	-	-		
$I_{EBO}$	Emitter Cutoff Current	$V_{BE}=5\text{ V}$	BDX63	-	-	5.0	mA	
			BDX63A					
			BDX63B					
			BDX63C					
$I_{CBO}$	Collector-Base Cutoff Current		$V_{CBO}=60\text{ V}$	BDX63	-	-	0.2	
			$V_{CBO}=400\text{ V}$ $T_{CASE}=200^\circ\text{C}$				2	
			$V_{CBO}=80\text{ V}$				0.2	
			$V_{CBO}=50\text{ V}$ $T_{CASE}=200^\circ\text{C}$				2	
			$V_{CBO}=100\text{ V}$				0.2	
			$V_{CBO}=60\text{ V}$ $T_{CASE}=200^\circ\text{C}$				2	
			$V_{CBO}=120\text{ V}$				0.2	
			$V_{CBO}=70\text{ V}$ $T_{CASE}=200^\circ$				2	
$V_{CE(SAT)}$	Collector-Emitter saturation Voltage (*)	$I_C=3.0\text{ A}$ $I_B=12\text{ mA}$	BDX63	-	-	2	V	
			BDX63A					
			BDX63B					
			BDX63C					
$V_F$	Forward Voltage (pulse method)	$I_F=3\text{ A}$	BDX63	-	1.2	-	V	
			BDX63A					
			BDX63B					
			BDX63C					
$V_{BE}$	Base-Emitter Voltage (*)	$I_C=3.0\text{ A}$ $V_{CE}=3\text{ V}$	BDX63	-	-	2.5	V	
			BDX63A					
			BDX63B					
			BDX63C					

## BDX63 – A – B – C

### ELECTRICAL CHARACTERISTICS

TC=25°C unless otherwise noted

Symbol	Ratings	Test Condition(s)	Min	Typ	Max	Unit		
$F_{hfe}$	Cut-off frequency	$V_{CE}=3\text{ V}$ $I_C=3\text{ A}$	BDX63	-	100	-	kHz	
			BDX63A					
			BDX63B					
			BDX63C					
$f_T$	Transition Frequency	$V_{CE}=3\text{ V}$ , $I_C=3\text{ A}$ $f=1\text{ MHz}$	BDX63	-	7	-	MHz	
			BDX63A					
			BDX63B					
			BDX63C					
$h_{FE}$	D.C. current gain (*)	$V_{CE}=3\text{ V}$ $I_C=0.5\text{ A}$	BDX63	-	2500	-	-	
			BDX63A					
			BDX63B					
			BDX63C					
		$V_{CE}=3\text{ V}$ $I_C=3\text{ A}$	BDX63	1000	-	-		-
			BDX63A					
			BDX63B					
			BDX63C					
		$V_{CE}=3\text{ V}$ $I_C=8\text{ A}$	BDX63	-	2600	-		-
			BDX63A					
			BDX63B					
			BDX63C					

(\*) Pulse Width  $\approx 300\ \mu\text{s}$ , Duty Cycle  $\angle 2.0\%$

## BDX63 – A – B – C

### MECHANICAL DATA CASE TO-3

DIMENSIONS (mm)		
	min	max
A	11	13.10
B	0.97	1.15
C	1.5	1.65
D	8.32	8.92
F	19	20
G	10.70	11.1
N	16.50	17.20
P	25	26
R	4	4.09
U	38.50	39.30
V	30	30.30

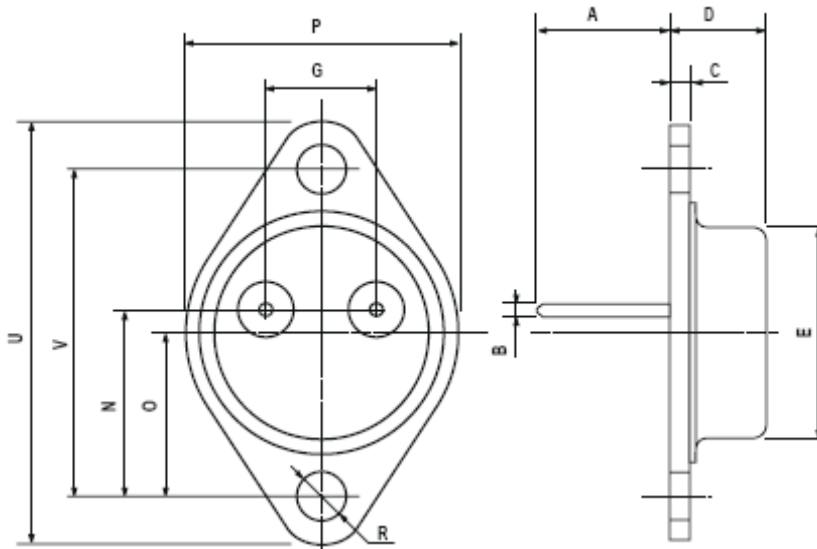

Pin 1 :	Base
Pin 2 :	Emitter
Case :	Collector

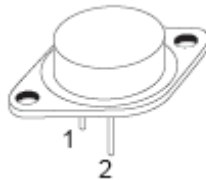

Revised September 2012

Information furnished is believed to be accurate and reliable. However, Comset Semiconductors assumes no responsibility for the consequences of use of such information nor for any infringement of patents or other rights of third parties which may result from its use. Data are subject to change without notice. Comset Semiconductors makes no warranty, representation or guarantee regarding the suitability of its products for any particular purpose, nor does Comset Semiconductors assume any liability arising out of the application or use of any product and specifically disclaims any and all liability, including without limitation consequential or incidental damages. Comset Semiconductors' products are not authorized for use as critical components in life support devices or systems.