

PNP TIP125-126-127

SILICON DARLINGTON POWER TRANSISTORS

PNP epitaxial-base transistors in a monolithic Darlington circuit and housed in a TO-220 envelope. They are intended for use in power linear and switching applications.

NPN complements are TIP120-121-122

Compliance to RoHS.

ABSOLUTE MAXIMUM RATINGS

Symbol	Ratings		Value	Unit	
V_{CBO}	Collector-Base Voltage		TIP125	-60	V
			TIP126	-80	
			TIP127	-100	
V_{CEO}	Collector-Emitter Voltage		TIP125	-60	V
			TIP126	-80	
			TIP127	-100	
V_{EBO}	Emitter-Base Voltage		TIP125	-5	V
			TIP126		
			TIP127		
I_C	Collector Current		TIP125	-5	A
			TIP126		
			TIP127		
I_{CM}	Collector Peak Current		TIP125	-8	A
			TIP126		
			TIP127		
I_B	Base Current		TIP125	-120	mA
			TIP126		
			TIP127		
P_T	Power Dissipation	@ $T_c < 25^\circ$	TIP125	65	W
			TIP126		
			TIP127		
		@ $T_a < 25^\circ$	TIP125	2	
			TIP126		
			TIP127		
T_J	Junction Temperature		TIP125	150	$^\circ\text{C}$
			TIP126		
			TIP127		
T_s	Storage Temperature range		TIP125	-65 to +150	
			TIP126		
			TIP127		

PNP TIP125-126-127

THERMAL CHARACTERISTICS

Symbol	Ratings	Value	Unit
$R_{thJ-case}$	From junction-case	1.92	°C/W
$R_{thJ-amb}$	From junction-ambient	62.5	°C/W

ELECTRICAL CHARACTERISTICS

TC=25°C unless otherwise noted

Symbol	Ratings	Test Condition(s)	Min	Typ	Max	Unit	
I_{CBO}	Collector Cutoff Current	$I_E = 0$ $V_{CB} = -V_{CB0max}$	TIP125	-	-	-0.2	mA
			TIP126				
			TIP127				
I_{CEO}	Collector Cutoff Current	$I_E = 0$ $V_{CE} = 1/2 -V_{CE0max}$	TIP125	-	-	-0.5	mA
			TIP126				
			TIP127				
I_{EBO}	Emitter Cutoff Current	$V_{EB} = -5 V$ $I_C = 0$	TIP125	-	-	-2	mA
			TIP126				
			TIP127				
V_{CEO}	Collector-Emitter Breakdown Voltage (*)	$I_C = -30 mA$ $I_B = 0$	TIP125	-60	-	-	V
			TIP126	-80	-	-	
			TIP127	-100	-	-	
$V_{CE(SAT)}$	Collector-Emitter saturation Voltage (*)	$I_C = -3 A$ $I_B = -12 mA$	TIP125	-	-	-2	V
			TIP126				
			TIP127				
		$I_C = -5 A$ $I_B = -20 mA$	TIP125	-	-	-4	
			TIP126				
			TIP127				
$V_{BE(on)}$	Base-Emitter Voltage (*)	$I_C = -3 A$ $V_{CE} = -3 V$	TIP125	-	-	-2.5	V
			TIP126				
			TIP127				
h_{FE}	DC Current Gain (*)	$V_{CE} = -3.0 V$ $I_C = -0.5 A$	TIP125	1000	-	-	-
			TIP126				
			TIP127				
		$V_{CE} = -3.0 V$ $I_C = -3 A$	TIP125	1000	-	-	
			TIP126				
			TIP127				
C_{OB}	Output Capacitance	$I_E = 0, V_{CB} = -10 V$ $f_{test} = 1MHz$	TIP125	-	-	200	pF
			TIP126				
			TIP127				

(*) Pulse Width $\approx 300 \mu s$, Duty Cycle $\angle 2.0\%$

PNP TIP125-126-127

MECHANICAL DATA CASE TO-220

DIMENSIONS (mm)		
	Min.	Max.
A	9,90	10,30
B	15,65	15,90
C	13,20	13,40
D	6,45	6,65
E	4,30	4,50
F	2,70	3,15
G	2,60	3,00
H	15,75	17,15
L	1,15	1,40
M	3,50	3,70
N	-	1,37
P	0,46	0,55
R	2,50	2,70
S	4,98	5,08
T	2,49	2,54
U	0,70	0,90

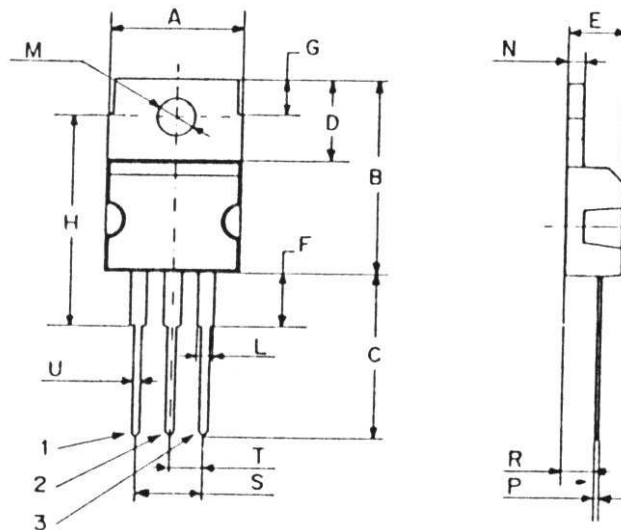

Pin 1 :	Base
Pin 2 :	Collector
Pin 3 :	Emitter
Case :	Collector

Revised August 2012

Information furnished is believed to be accurate and reliable. However, Comset Semiconductors assumes no responsibility for the consequences of use of such information nor for any infringement of patents or other rights of third parties which may result from its use. Data are subject to change without notice. Comset Semiconductors makes no warranty, representation or guarantee regarding the suitability of its products for any particular purpose, nor does Comset Semiconductors assume any liability arising out of the application or use of any product and specifically disclaims any and all liability, including without limitation consequential or incidental damages. Comset Semiconductors' products are not authorized for use as critical components in life support devices or systems.