



## NPN BD683 – BD683A

### SILICON DARLINGTON POWER TRANSISTORS

The BD683 and BD683A are NPN epitaxial-base transistors in monolithic Darlington circuit for audio and video applications.

They are mounted in Jedec TO-126 plastic package.

PNP complements are BD684 and BD684A.

Compliance to RoHS

#### ABSOLUTE MAXIMUM RATINGS

Symbol	Ratings	Value	Unit
$V_{CEO}$	Collector-Emitter Voltage	120	V
$V_{CBO}$	Collector-Base Voltage	120	V
$V_{EBO}$	Emitter-Base Voltage	5	V
$I_C$	Collector Current	$I_C$	4
		$I_{CM}$	6
$I_{BM}$	Base current peak value	0.1	A
$P_T$	Total power Dissipation @ $T_{mb} = 25^\circ\text{C}$	40	W
$T_J$	Junction Temperature	150	$^\circ\text{C}$
$T_{Stg}$	Storage Temperature	-65 to +150	$^\circ\text{C}$

#### THERMAL CHARACTERISTICS

Symbol	Ratings	Value	Unit
$R_{thJ-mb}$	Thermal Resistance, Junction to mounting base	3.12	K/W
$R_{thJ-a}$	Thermal Resistance, Junction to ambient in free air	100	K/W

## NPN BD683 – BD683A

### ELECTRICAL CHARACTERISTICS

TC=25°C unless otherwise noted

Symbol	Ratings	Test Condition(s)	Min	Typ	Max	Unit
$I_{CBO}$	Collector cut-off current	$I_E=0, V_{CB}= 120\text{ V}$	-	-	0,2	mA
		$I_E=0, V_{CB}= 120\text{V}, T_j= 150^\circ\text{C}$	-	-	2	
$I_{CEO}$	Collector cut-off current	$I_B=0, V_{CE}= 1/2V_{CEOMAX}$	-	-	0,5	mA
$I_{EBO}$	Emitter cut-offcurrent	$I_C=0, V_{EB}=5\text{ V}$	-	-	5	mA
$V_{CE(SAT)}$	Collector-Emitter saturation Voltage (*)	$I_C=1.5\text{ A}, I_B=30\text{ mA}$ BD683	-	-	2,5	V
		$I_C=2\text{ A}, I_B=40\text{ mA}$ BD683A	-	-	2,8	
$h_{FE}$	DC Current Gain (*)	$V_{CE}=3\text{ V}, I_C=1.5\text{ A}$ BD683	750	-	-	-
		$V_{CE}=3\text{ V}, I_C=2\text{ A}$ BD683A				
$V_{BE}$	Base-Emitter Voltage (*)	$V_{CE}=3\text{ V}, I_C=1.5\text{ A}$ BD683	-	-	2,5	V
		$V_{CE}=3\text{ V}, I_C=2\text{ A}$ BD683A				
$h_{fe}$	Small signal current gain	$V_{CE}=3\text{ V}, I_C=1.5\text{ A}, f= 1\text{ MHz}$	10	-	-	-
$f_{hfe}$	Ut-off frequency	$V_{CE}=3\text{ V}, I_C=1.5\text{ A}$	-	60	-	kHz
$V_F$	Diode forward voltage	$I_F=1,5\text{ A}$	-	1,5	-	V
$I_{(SB)}$	Second-breakdown collector current	$V_{CE}=50\text{ V}, t_p= 20\text{ms}, \text{non rep. without heatsink}$	0,8	-	-	A
$t_{on}$	Turn-on time	$I_{con}= 1.5\text{A}, -I_{bon}= I_{boff}= 6\text{mA}$	-	0,8	2	$\mu\text{s}$
$t_{off}$	Turn-off time	$V_{CC}=30\text{V}$	-	4,5	8	

(\*) Measured under pulse conditions : $t_p < 300\mu\text{s}, \delta < 2\%$ .

## NPN BD683 – BD683A

### MECHANICAL DATA CASE TO-126

	DIMENSIONS	
	min	max
A	7.4	7.8
B	10.5	10.8
C	2.4	2.7
D	0.7	0.9
E	2.25 typ.	
F	0.49	0.75
G	4.4 typ.	
L	15.7 typ.	
M	1.27 typ.	
N	3.75 typ.	
P	3.0	3.2
S	2.54 typ.	

Pin 1 :	Emitter
Pin 2 :	Collector
Pin 3 :	Base

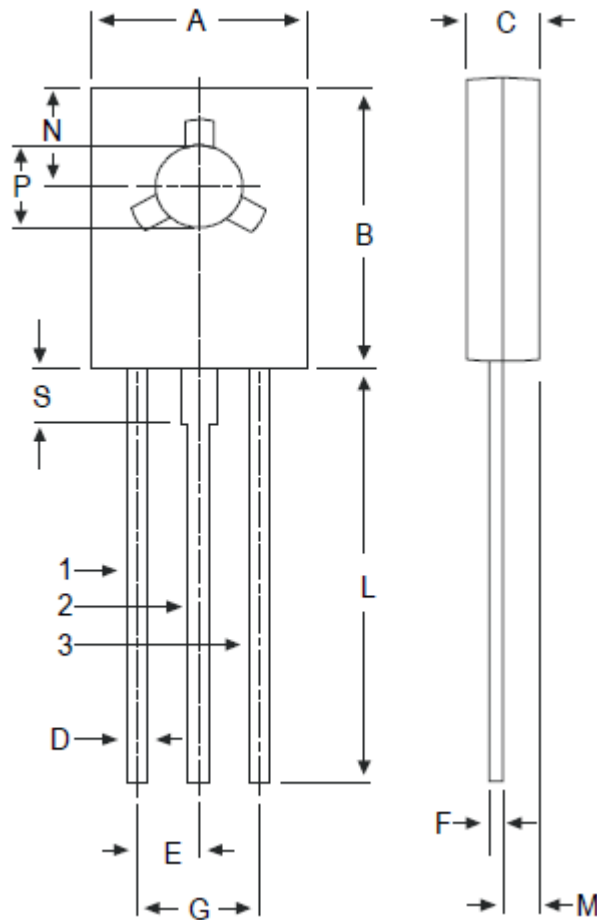

Revised August 2012

Information furnished is believed to be accurate and reliable. However, Comset Semiconductors assumes no responsibility for the consequences of use of such information nor for any infringement of patents or other rights of third parties which may result from its use. Data are subject to change without notice. Comset Semiconductors makes no warranty, representation or guarantee regarding the suitability of its products for any particular purpose, nor does Comset Semiconductors assume any liability arising out of the application or use of any product and specifically disclaims any and all liability, including without limitation consequential or incidental damages. Comset Semiconductors' products are not authorized for use as critical components in life support devices or systems.