

# VFOV200

## OCXO – High Frequency, High Stability

### HCMOS / SINEWAVE

#### Features

- 5MHz to 250MHz Frequency Range
- High Stability ( up to 5ppb over -40~+85°C )
- Sine Wave or HCMOS output

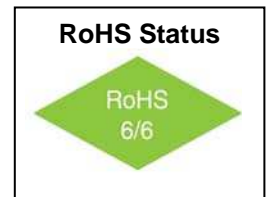

#### Applications

- PLL reference for Telecommunication Systems
- Stratum 3E clock systems
- Base station reference source
- GPS holdover
- Instrumentation / Test and Measurement

#### Electrical Specifications

Parameter	Symbol	Condition	Min	Typ	Max	Unit	Note
Frequency Range	F		5		250	MHz	
Frequency Stability	$\Delta F/F$	Vs. Operating Temp. E: -30°C to +70°C		$\pm 10$		ppb	STD option shown. See "How to Order" Chart below
		Vs. Supply Voltage		$\pm 1$		ppb	Ref. Vcc typ.
		Vs. Aging / Day Vs. Aging / Year		0.5 0.1		ppb ppm	after 30 days 0.2ppb available
Operating Temperature Range	T		-30°		+70°	°C	STD option shown. See "How to Order" Chart below
Allan Variance		1s		10e-12			
SSB Phase Noise		10Hz		-125		dBc/Hz	For 10MHz Oscillator  (For 100MHz see plot next page)
		100Hz		-143			
		1KHz		-150			
		10KHz		-158			
		100KHz		-160			
Retrace		After 30 min.			$\pm 10$	ppb	
G-sensitivity		worst direction			$\pm 1$	ppb/g	
Supply Voltage	Vcc		11.4	12.0	12.6	V	
			4.75	5.0	5.25		
			3.10	3.3	3.50		
Power Consumption	P	steady state, 25°C		1.0	1.2	W	
		steady state, -30°C		2.0	2.2		
		start-up		3.2	3.5		
Warm up time	$\tau$	to 0.1ppm accuracy		2	3	min	

# VFOV200

## OCXO – High Frequency, High Stability

### HCMOS / SINEWAVE



#### Electrical Specifications

Parameter	Symbol	Condition	Min	Typ	Max	Unit	Note
HCMOS / TTL Output Levels		HCMOS/TTL	10KOhm / 15pF				Order Code H
	V <sub>H</sub>	V <sub>cc</sub> = 5 or 12V V <sub>cc</sub> =3.3V	3.9 2.4			V	
	V <sub>L</sub>				0.4	V	
Rise / Fall time		At 100MHz			10	ns	
Duty Cycle			45		55	%	
Sine-Wave Output Levels		V <sub>cc</sub> =5 or 12V	+6	+8	+10	dBm	Order Code S
	R <sub>L</sub>			50		Ω	
Harmonics					-25	dBc	
Sub-Harmonics		Frequency <30Mhz Frequency >30MHz	None		-40	dBc	**Multiplied fundamental
Control Voltage	V <sub>c</sub>	V <sub>cc</sub> = 5 or 12V V <sub>cc</sub> =3.3V	0 0		4.3 2.8	V	
Pull Range		from nominal F	±0.5	±1		ppm	
Deviation slope		Monotonic, Positive		0.4		ppm/ V	
Reference output	V <sub>ref</sub>	V <sub>cc</sub> = 5 or 12V V <sub>cc</sub> =3.3V	4.19 2.73	4.3 2.8	4.41 2.87	V	

\*\* High frequency fundamental (up to 120MHz) available without sub-harmonics. Please refer to VFOV100.

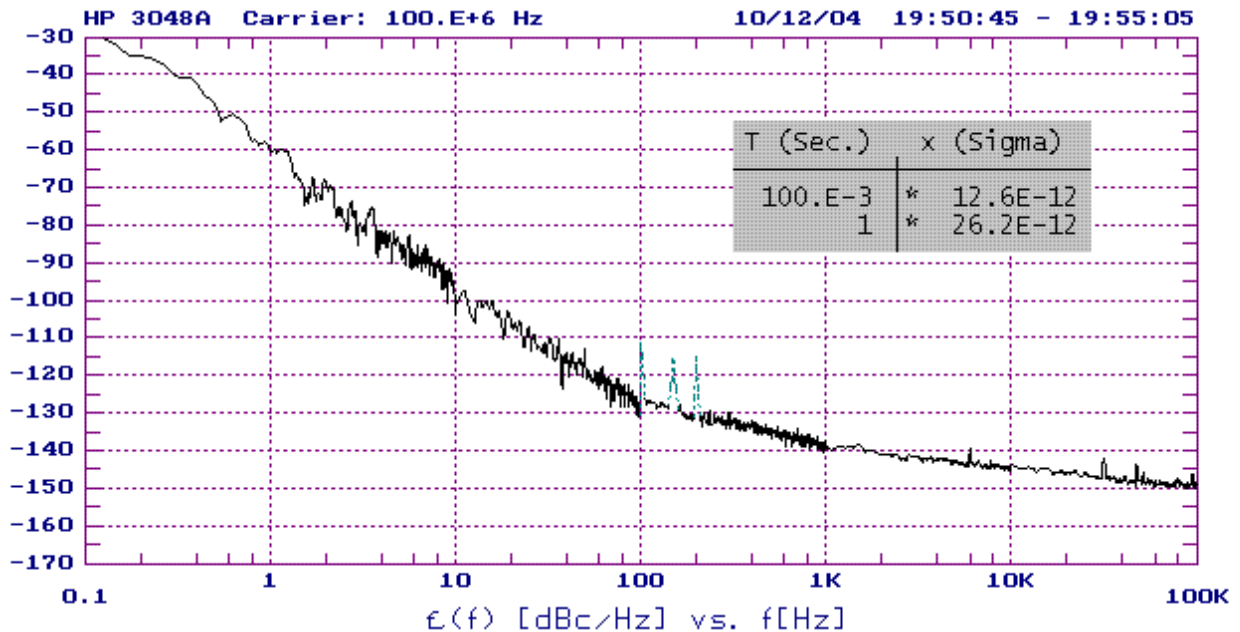

100MHz output with internal multiplied 20MHz fundamental Crystal

# VFOV200

## OCXO – High Frequency, High Stability

### HCMOS / SINEWAVE



#### Absolute Maximum Ratings

Parameter	Symbol	Condition	Min	Typ	Max	Unit	Note
Supply Break Down Voltage	V <sub>cc</sub>		-0.5		V <sub>cc</sub> +20%	V	
Control Voltage	V <sub>c</sub>		-1		9	V	

#### Environmental and Mechanical

Parameter	Specification
Storage Temperature	-60°C to +90°C
Humidity	Hermetically Sealed
Mechanical Shock	Per MIL-STD-202, 30g, half sine, 11ms
Vibration	Per MIL-STD-202, 10g swept Sine to 2000Hz
Soldering Conditions	260°C for 10s

#### How to Order

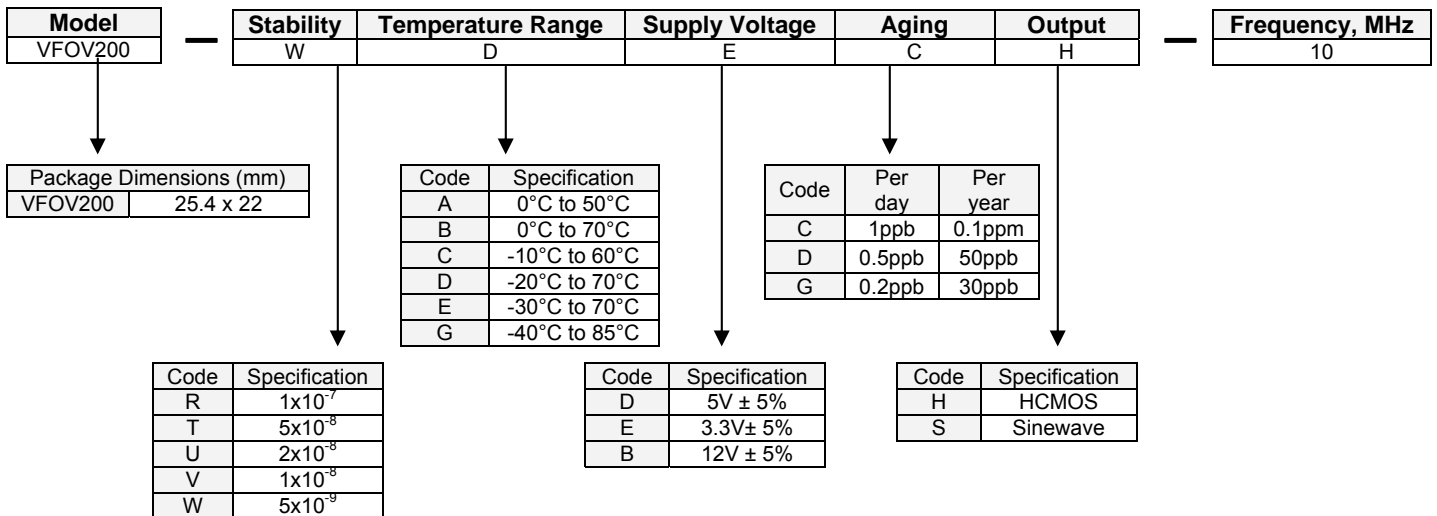

#### Available Frequency Stabilities over Operating Temperature Ranges

Order Code	Temperature Range	Stability				
		1x10 <sup>-7</sup>	5x10 <sup>-8</sup>	2x10 <sup>-8</sup>	1x10 <sup>-8</sup>	5x10 <sup>-9</sup>
A	0°C to 50°C	*	*	*	*	*
B	0°C to 70°C	*	*	*	*	◇
C	-10°C to 60°C	*	*	*	*	*
D	-20°C to 70°C	*	*	*	*	◇
E	-30°C to 70°C	*	*	*	*	◇
G	-40°C to 85°C	*	*	*	*	◇

◇ Only available below 30MHz

# VFOV200

## OCXO – High Frequency, High Stability

### HCMOS / SINEWAVE

#### Package



VFOV200

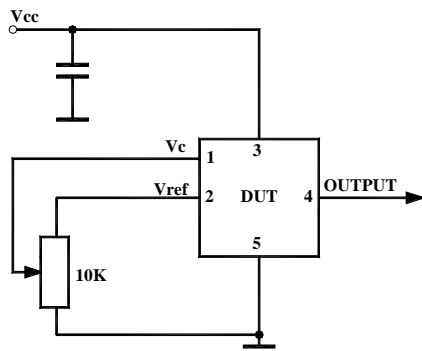
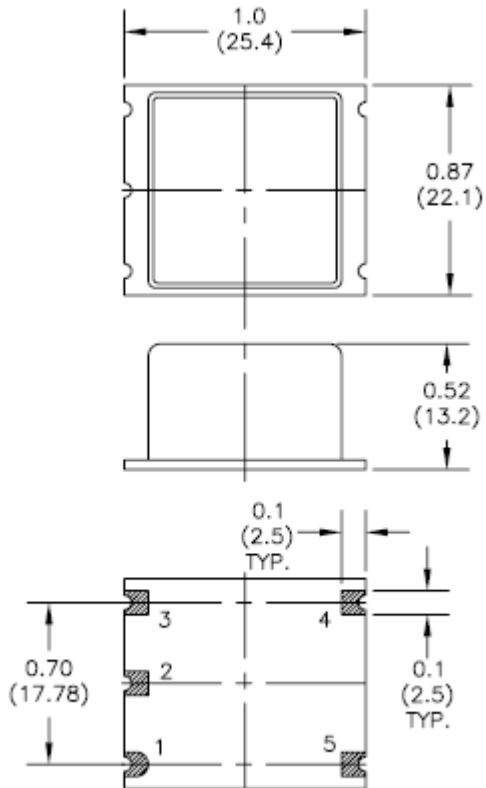

Pin #	Connection
1	Vc
2	Vref
3	Vcc
4	Output
5	GND