

### APPLICATIONS

Frequency Translation and Jitter Attenuation  
 SONET/ SDH  
 10 GbE  
 WiMAX  
 Base Stations/ Picocells  
 DAC clocking

### FEATURES

- High Tuning Gain Transfer, Kv
- Industry Standard 5x7mm SMT Footprint
- +3.3 Vdc Supply Voltage
- -40°C to 85°C Temp. Range
- LVPECL differential outputs
- ± 50ppm Absolute Pull Range (APR)
- Output Enable/Disable Function
- SAW filter design
- Extremely Low Jitter

### DESCRIPTION

Surface mount 5x7mm VCSO operating at 3.3V supply with complementary LVPECL outputs for use in datacom, telecom, and DAC clock applications.

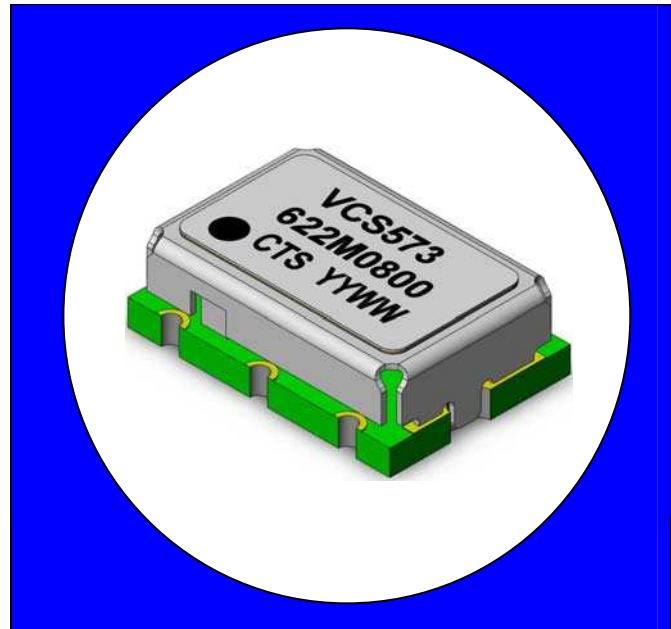

### ELECTRICAL SPECIFICATIONS

Parameter	Conditions & Remarks	Min	Typical	Max	Unit
<b>Operating Conditions</b>					
Nominal Frequency	$f_{NOM}$	600	622.08, 644.5313, 666.514, 669.3266 693.483, 768	1000	MHz
Operating Temperature Range		-40	-	85	°C
Storage Temperature Range		-55	-	125	°C
Supply Voltage	$V_{CC}; \pm 5\%$	3.135	3.300	3.465	Vdc
Supply Current	$I_{CC}; \text{Max. } V_{CC}; T_A = 25^\circ\text{C}$ load = $50\Omega$ to $V_{CC} - 2V$	-	65	75	mA
Load	output to $V_{CC} - 2V$	-	50	-	$\Omega$
<b>Frequency Stability</b>					
Frequency vs. Temperature	ref to $T_A = 25^\circ\text{C}; V_C = \text{constant}$	-	+20 -160	-	ppm
<b>Electronic Frequency Control</b>					
Input Impedance	$Z_i$	50	100	-	k $\Omega$
Control Voltage Range	$V_C$ ; positive monotonic transfer	0.3	-	3.0	Vdc
Gain Transfer	Kv	-	350	-	ppm/V
Absolute Pull Range	APR; all causes (see Note 1)	± 50	-	-	ppm
Modulation Bandwidth	-3dB ref. 100Hz	-	50	-	kHz
Linearity	Deviation from best linear fit	-	±4	±10	%

NOTE 1: Minimum guaranteed frequency shift ( $\Delta f/f_{NOM}$ ) under all conditions (temperature, aging, supply voltage, load) for 15 years at an average effective operating temperature of +55°C

### ELECTRICAL SPECIFICATIONS (Continued)

Parameter	Conditions & Remarks	Min	Typical	Max	Unit	
<b>Output Parameters</b>						
Output Signal		LVPECL				
Amplitude		$V_{OL}$	-	-	$V_{CC}-1.620$	Vdc
		$V_{OH}$	$V_{CC}-1.025$	-	-	
Rise/Fall Times	20% to 80%	-	250	400	ps	
Duty Cycle	@ 50% of output signal	45	50	55	%	
Start up time	to reach 90% of final amplitude	-	-	10	ms	
Phase Noise	Typical for 622.08 MHz	100Hz	-	-85	-	dBc/Hz
		1kHz	-	-110	-	dBc/Hz
		10kHz	-	-140	-	dBc/Hz
		100kHz	-	-143	-	dBc/Hz
		1MHz	-	-143	-	dBc/Hz
Phase Jitter	12kHz to 20MHz (calculated from 622 MHz Phase Noise)	-	0.10	0.25	ps RMS	
	50kHz to 80MHz (calculated from 622 MHz Phase Noise)	-	0.10	0.25	ps RMS	

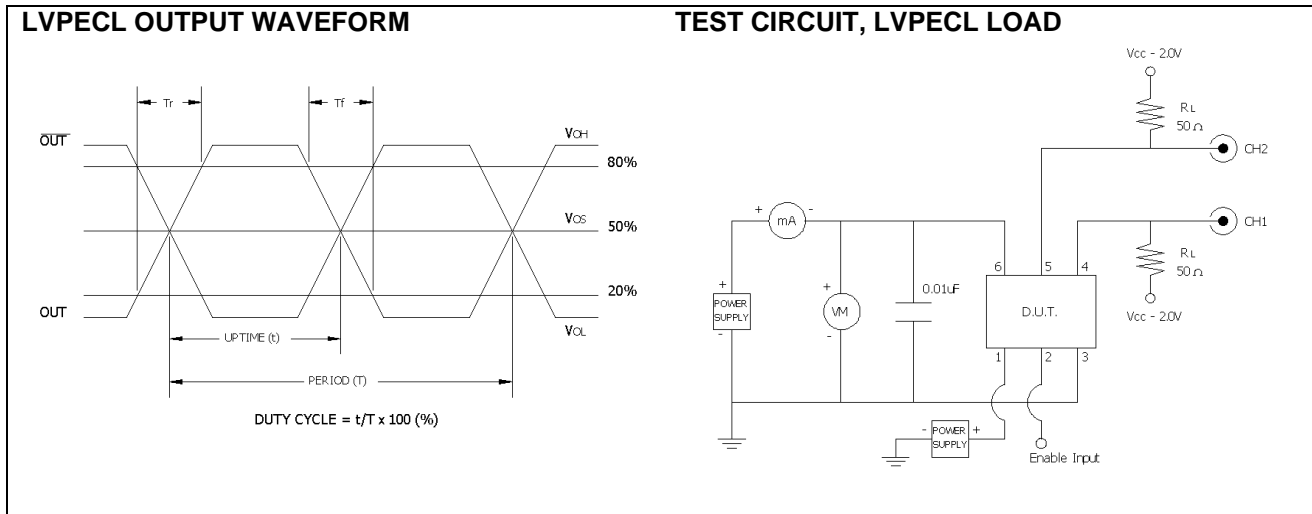

OUTPUT ENABLE/DISABLE LOGIC			
Pad 2		Pad 4	Pad 5
Low "0"	outputs disabled	PECL Low	PECL High
Open	outputs enabled	Output	Comp. Output
High "1"	outputs enabled	Output	Comp. Output

### MECHANICAL SPECIFICATIONS

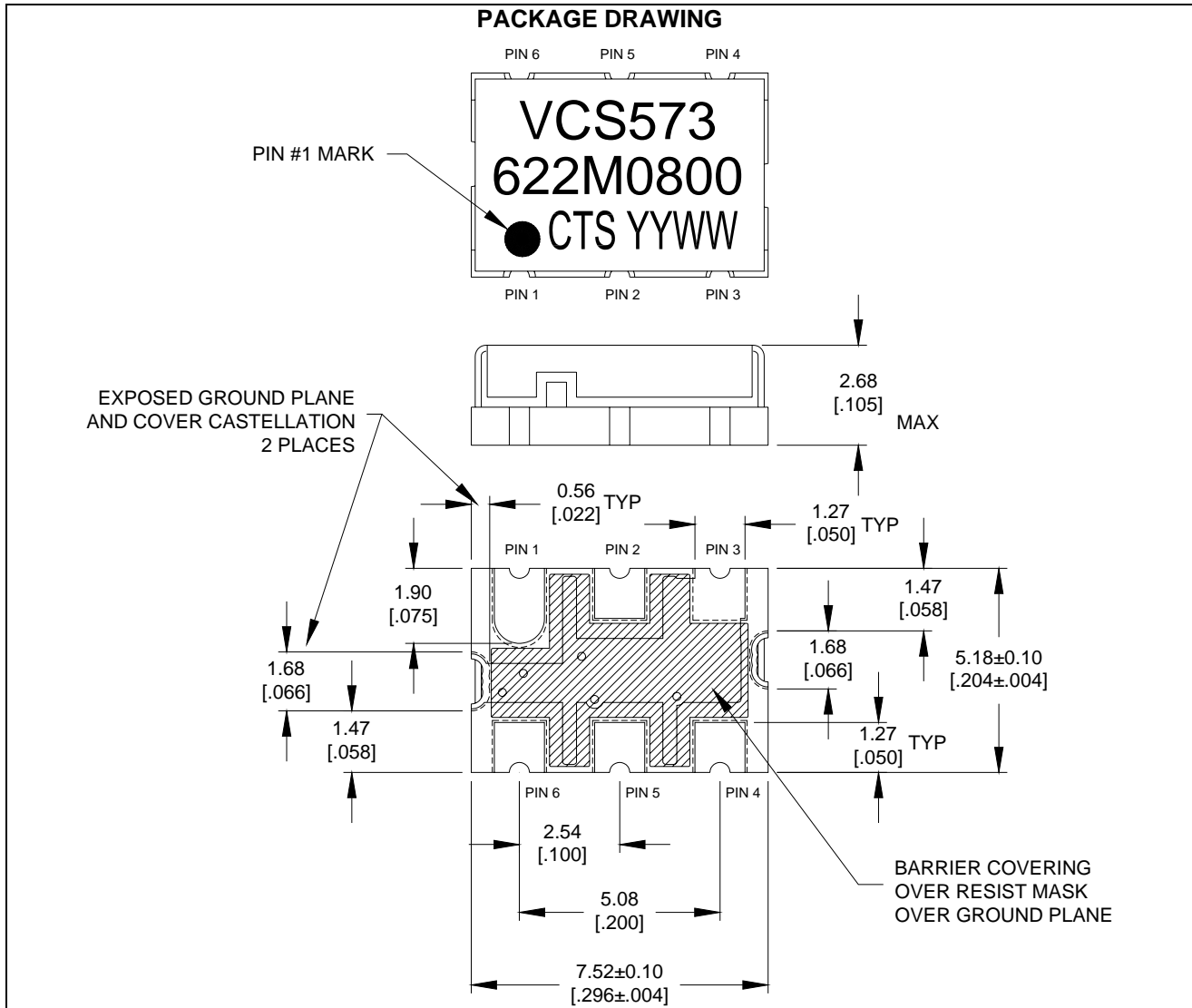

**Lead Termination Finish:** Gold flash, <10 micro inch, over 100 micro inch minimum Ni plated Cu

**Co-Planarity** (from seating plane): 0.1 [0.004] maximum

Dimensions in mm and [inches]

#### PAD FUNCTION

- 1 - Control Voltage -  $V_C$
- 2 - Enable/Disable Control
- 3 - Ground/Case
- 4 - Output
- 5 - Complementary Output
- 6 - Supply Voltage -  $V_{CC}$

### SUGGESTED SOLDER PAD GEOMETRY

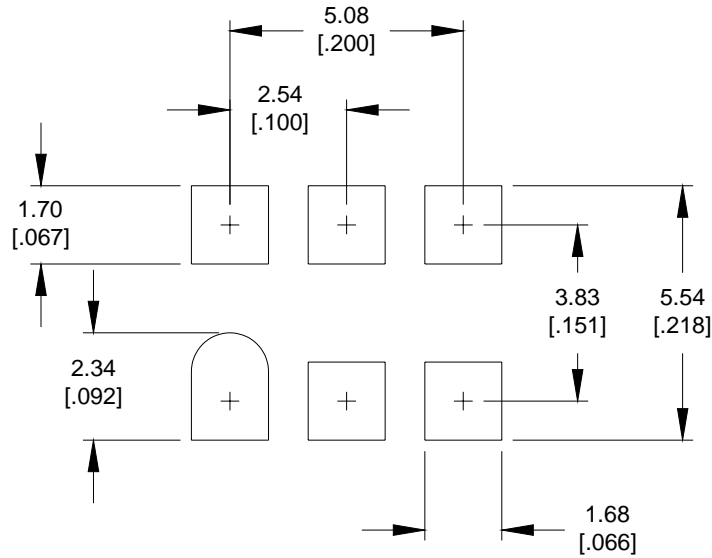

Dimensions are in mm and [inches].

### MAXIMUM SOLDERING PROFILE

Temperature	217°C	260°C (Absolute max temperature)
Time	60-150 sec	10 sec. max
Note: Part is not designed to be reflowed in an inverted position.		

### TAPE AND REEL INFORMATION

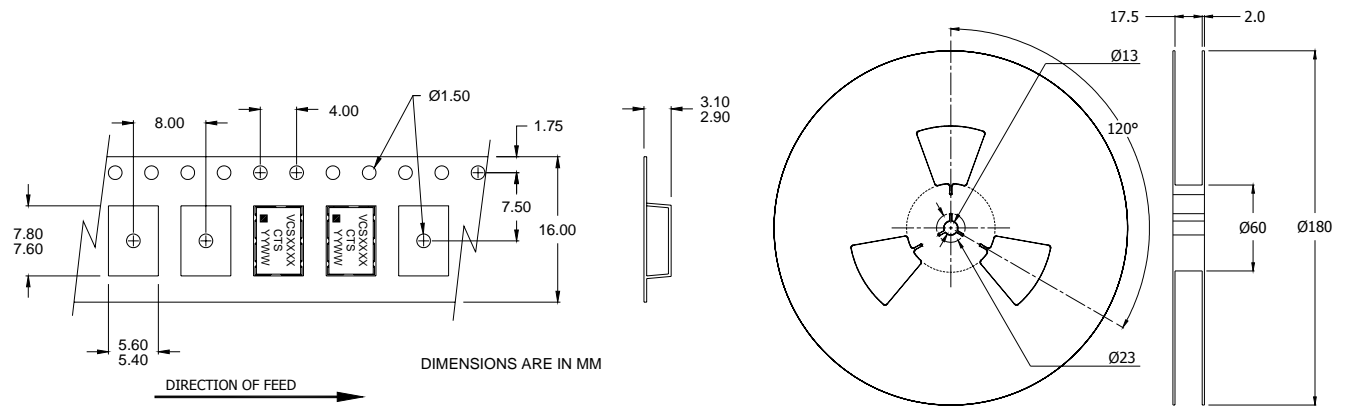

Device quantity is 1000 pieces max. per 180mm reel.

## ENVIRONMENTAL SPECIFICATIONS

This product is capable of operating within the following environmental conditions:

Operating Temperature	-40 to +85 °C
Storage Temperature	-55 to 125°C
Humidity	95% Relative humidity max @ 40°C
Atmospheric Pressure	730 to 780 mm Hg
Moisture Sensitivity	Level 1
RoHS	Fully compliant to RoHS Directive 2002/95/EC

### Model 3571 Part Number Generator:

VCS573 - \_ \_ \_ M \_ \_ \_

Frequency in MHz  
("M" = decimal point)

P/N example: VCS573-622M0800