

VFFT401

Quad Output

Frequency Translator

Features

- 1.5 GHz Output Frequency Range
- 4 Selectable Output Frequencies
- Low Power: <220mW typical
- Low Profile SMD package

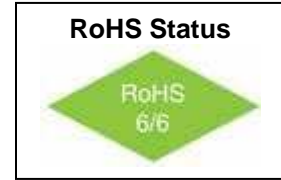
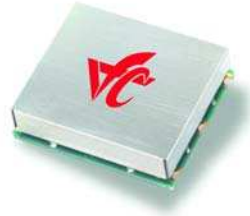

Applications

- Optical Networking, Sonet / SDH / ATM
- 10 Gigabit Ethernet
- Forward Error Correction (FEC)

Description

The VFFT401 is a Frequency Translator which accepts an input frequency from 100 to 800MHz and provides an output frequency from 400 to 1.5GHz. Up to four input and output combinations are possible. Each I/O is preset and determined by the frequency select inputs [S1:S0]. A Lock Detect output signal indicates an “out of lock” condition. The device is implemented with a Phase Locked Loop where all Loop Filter components are integrated into the module. The VFFT401 is offered in a 19.5mm x17mm surface mount package. Consult factory for frequency selections.

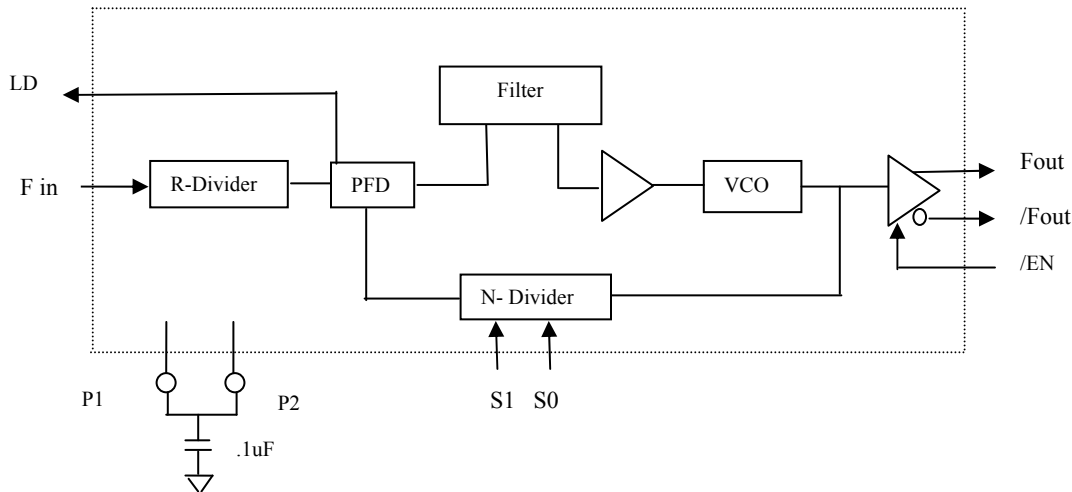

Block Diagram

VFFT401

Quad Output Frequency Translator



Absolute Maximum Ratings

Parameter	Min	Max	Units
Power Supply Voltage	-0.50	+4.0	Volts
Storage Temperature	-45	+90	° C

Operating Specification

Parameter	Specification	Notes
Supply Voltage	3.3 Volts +/- 5%	
Supply Current	80mA (max)	
Output Frequencies (F0) – F0(3)	400 to 1500 MHz	See Table 2
Output Frequency Range	100MHz (max)	F _{OUT} Min to F _{OUT} Max
Output Configuration	Differential LVPECL	Unterminated
Jitter RMS	0.250ps (typ)	50 KHz to 80 MHz
Input frequency Fin(0) – Fin (3)	100 to 800 MHz	See Table 2
Input configuration	Single-ended, AC coupled	
Input Level	150 mVp-p(min) / 900mV (max)	Fin > 200 MHz
Input Level	400 mVp-p (min) / 3.3V (max)	
Modulation Bandwidth	1 K Hz	Consult Factory for options
Start up Time	300 mS (max)	
I/O Select Inputs	S1: S0	LVC MOS See Note 1
Lock Detect Output (LD)	Logic "1" : In lock Logic "0" : Out of lock	LVC MOS
Lock / Capture Range	1% (min)	
Operating Temperature Range	-40 °C to +85 °C	

Example

Table 1

Input Frequency	Output Frequency	I / O Ratio	Select inputs [S1 : S0]
669.32658 MHz	622.080 MHz	85 / 79	0 0
669.32658 MHz	669.32658 MHz	1 / 1	0 1
693.48315 MHz	644.5314 MHz	85 / 79	1 0
704.38 MHz	657.4213 MHz	90 / 84	1 1

Notes

1. The input frequency must be within 500ppm of final value before asserting the "Select Inputs."



VFFT401

Quad Output Frequency Translator



Pin Assignments

Pin #	Symbol	Description	Notes
1	Fin	Input Frequency	
2	Gnd	Ground	
3	S1	I/O Select (msb)	
4	LD	Lock Detect	
5	S0	I/O Select (lsb)	
6	DNC	Do not connect to this pad	
7	DNC	Do not connect to this pad	
8	Vcc	3.3 Volt Power Supply	
9	Gnd	Ground	
10	/OE	Output Disable	
11	/Fout	Complimentary Output	
12	Fout	Output	
13	P1	Connect to P2 externally	Add .1 uF Capacitor
14	P2	Connect to P1 externally	

Mechanical Outline

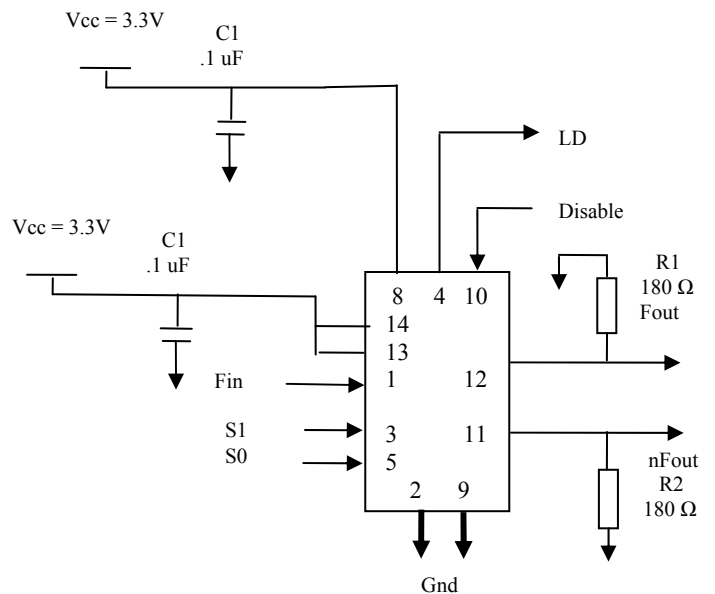
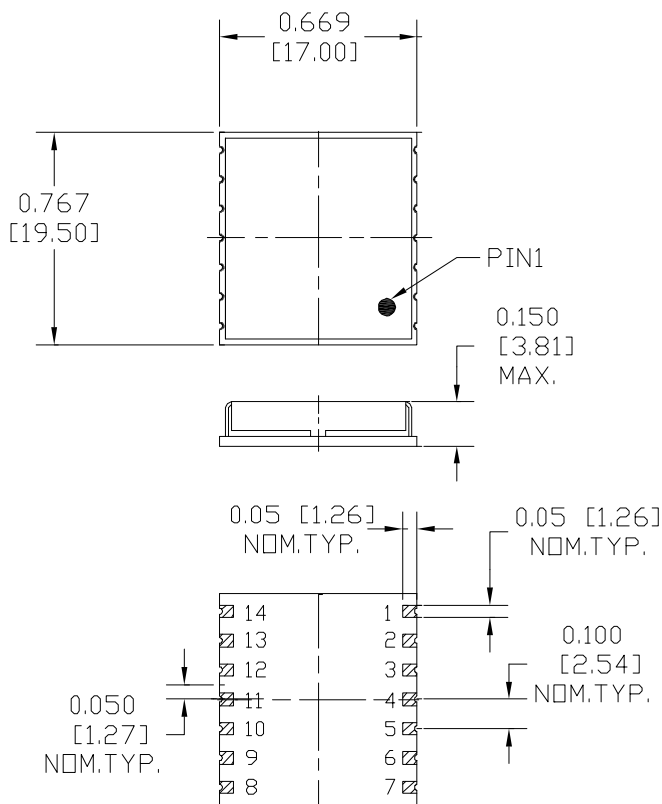

VFFT401

Quad Output Frequency Translator



Ordering Information:

Once Input and Output frequencies have been submitted and approved, the Factory will assign a part number.

VFFT401 -

Sample Frequencies **Table 2**

P/N suffix	S1:S0	Input Frequency (MHz)	Output Frequency (MHz)		P/N suffix	S1:S0	Input Frequency (MHz)	Output Frequency (MHz)
-001	00	622.080	669.32658		-002	00	669.32658	622.080
	01	669.32658	669.32658			01	669.32658	669.32658
	10	644.5314	693.48315			10	693.48315	644.5314
	11	657.4213	704.38			11	704.38	657.4213
-003	00	155.5200	669.32658		-004	00	167.331645	622.080
	01	167.33164	669.32658			01	167.331645	669.32658
	10	161.13285	693.48315			10	173.370787	644.5314
	11	164.355325	704.38			11	176.09500	657.4213