

# VFFT400

## Quad Output

## Frequency Translator



### Features

- 400 MHz Output Frequency Range
- 4 Selectable Output Frequencies
- Low Power: <220mW typical
- Low Profile SMD package

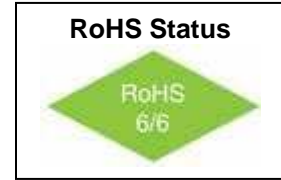
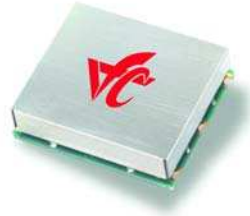

### Applications

- Optical Networking, Sonet / SDH / ATM
- 10 Gigabit Ethernet
- Forward Error Correction (FEC)

### Description

The VFFT400 is a Frequency Translator which accepts an input frequency from 8KHz to 200MHz and provides an output frequency from 50MHz to 400MHz. Up to four Input and Output combinations are possible. Each I/O is preset and determined by the frequency select inputs [S1:S0]. A Lock Detect output signal indicates an “out of lock” condition. The device is implemented with a Phase Locked Loop where all Loop Filter components are integrated into the module. The VFFT400 is offered in a 19.5mm x17mm surface mount package. Consult factory for frequency selections.

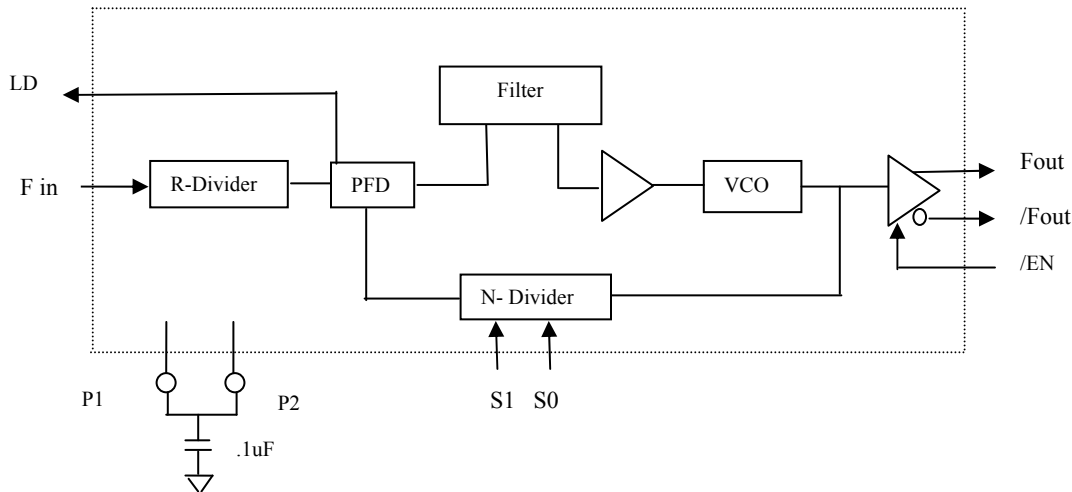

**Block Diagram**

# VFFT400

## Quad Output Frequency Translator



### Absolute Maximum Ratings

Parameter	Min	Max	Units
Power Supply Voltage	-.50	+4.0	Volts
Storage Temperature	-45	+90	° C

### Operating Specification

Parameter	Specification	Notes
Supply Voltage	3.3 Volts +/- 5%	
Supply Current	80mA (max)	
Output Frequencies (F0) – F0(3)	50 to 400 MHz	
Output Frequency Range	35 MHz (max)	F <sub>OUT</sub> min to F <sub>OUT</sub> max
Output Configuration	Differential LVPECL	Unterminated
Jitter (RMS)	0.450ps	50 KHz to 80 MHz
Input frequency Fin( 0) – Fin (3)	8 KHz to 200 MHz	
Input configuration	Single-ended, AC coupled	
Input Level	150 mVp-p(min) / 900mV (max)	Fin > 200 MHz
Input Level	400 mVp-p (min) / 3.3V (max)	
Modulation Bandwidth	1 K Hz	Consult Factory for options
Start up Time	300 ms (max)	
I/O Select Inputs	S1: S0	LVC MOS See Note 1
Lock Detect Output (LD)	Logic "1" : In lock Logic "0" : Out of lock	LVC MOS
Lock / Capture Range	1% ( min)	
Operating Temperature Range	-40 °C to +85 °C	

#### Notes

1. The input frequency must be within 500ppm of final value before asserting the "Select Inputs."

### Example

Table 1

Suffix	Input Frequency	Output Frequency	Select inputs [S1 : S0]
-001	156.25 MHz	155.52 MHz	0 0
	155.52 MHz	156.25 MHz	0 1
	156.25 MHz	161.1328 MHz	1 0
	161.1328 MHz	156.25 MHz	1 1

### Ordering Information:

Once Input and Output frequencies have been submitted and approved, the Factory will assign a part number.

VFFT400 - suffix



# VFFT400

## Quad Output Frequency Translator



### Pin Assignments

Pin #	Symbol	Description	Notes
1	Fin	Input Frequency	
2	Gnd	Ground	
3	S1	I/O Select (msb)	
4	LD	Lock Detect	
5	S0	I/O Select (lsb)	
6	DNC	Do not connect to this pad	
7	DNC	Do not connect to this pad	
8	Vcc	3.3 Volt Power Supply	
9	Gnd	Ground	
10	/OE	Output Disable	
11	/Fout	Complimentary Output	
12	Fout	Output	
13	P1	Connect to P2 externally	Add .1 uF Capacitor
14	P2	Connect to P1 externally	

### Mechanical Outline

