

VFJA910

25MHz Jitter Attenuator

Dual LVCMOS Output



Features

- 2 LVCMOS outputs
- Ultra Low Jitter 0.25ps RMS
- Phase Noise: -140 dBc/Hz @ 1KHz
- Low Power: < 120mW typical
- Free-run mode
- No external components required

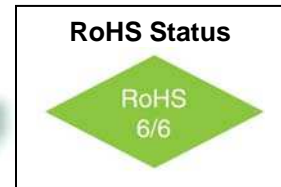
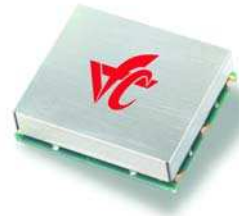

Applications

- Synchronous Ethernet

Description

The VFJA910 is a Jitter Attenuator that provides two LVCMOS outputs with a frequency of 25MHz. With less than 0.4 dBc of jitter peaking the device allows for cascading multiple stages within the network. A select input [Sel] allows the user to switch from the external input reference to a free-run mode. In free-run mode the device outputs a 25MHz clock that is not locked to the input reference frequency. Operating with a +3.3 volt power supply the device typically consumes 120mW. The VFJA910 is available in a 15.0mm x 13.0mm surface mount package.

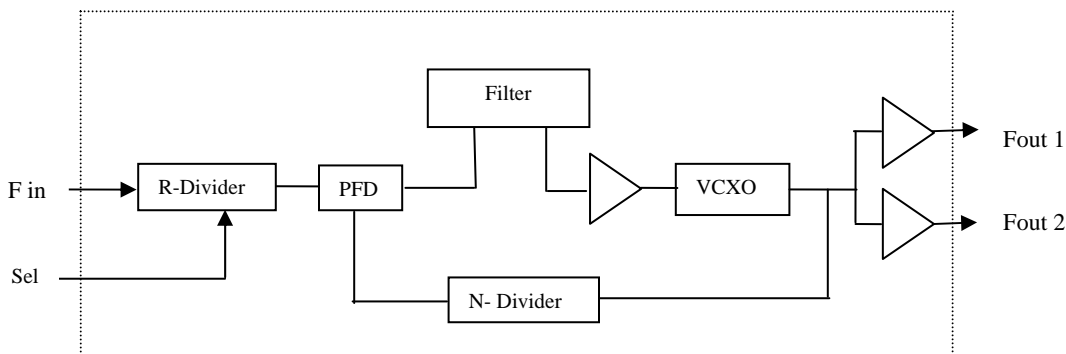

Block Diagram



VFJA910

25MHz Jitter Attenuator

Dual LVCMOS Output



Absolute Maximum Ratings

Parameter	Symbol	Condition	Min	Typ	Max	Unit	Note
Supply Break Down Voltage	V _{cc}		-0.5		5.5	V	
Storage Temperature	T _s		-55		+105°	°C	

Electrical Specifications

Parameter	Symbol	Condition	Min	Typ	Max	Unit	Note	
Output Frequency Range	F _{out}			25.0		MHz		
Input Frequency Range	F _{in}	Slew Rate 2.5V / ns (min)		25.0		MHz		
Input Level	V _{in}	AC coupled internally	0.4		3.3	V p-p		
Output Level Logic "1"	V _{oh}	I _{OH} = 8 mA	V _{cc} -1		V _{cc}	V		
Output Level Logic "0"	V _{ol}	I _{OL} = 8 mA	0.0		0.3	V		
Jitter RMS		12KHz to 20MHz		0.25	0.36	ps		
SSB Phase Noise	φ _n	100Hz 1KHz 10KHz 100KHz		-120 -140 -150 -160		dBc/Hz	@ 25 MHz	
APR			± 100			ppm		
Free-run Accuracy		-40°C to +85°C		60		ppm		
Modulation BW			30			Hz	Note 1	
Duty Cycle		@ 50%	45	50	55	%		
Rise / Fall Time	T _r /T _f	20% to 80%			0.6	ns		
Start up time				2	10	ms		
Select Input	Sel		Logic "1" = Free Run Mode Logic "0" = External Input Reference					LVCMOS
Supply Voltage	V _{cc}		3.15	3.30	3.45	V		
Input Current	I _{cc}			30	40	mA		
Operating Temperature Range	T _a		-40°		+85°	°C		



VFJA910

25MHz Jitter Attenuator

Dual LVCMOS Output



Environmental and Mechanical

Parameter	Specification
Mechanical Shock	Per MIL-STD-202, Method 213, Condition E
Thermal Shock	Per MIL-STD-883, Method 1011, Condition A
Vibration	Per MIL-STD-883, Method 2007, Condition A
Soldering Conditions	260°C for 10s max
Hermetic Seal	Leak rate less than 5×10^{-8} atm.cc/s of helium (crystal only)

Connection Diagram

Vcc = +3.3V

0.1 uF

0.1 uF

Fin

Sel

9 4

1 7

3 6

5 10

Gnd

Fout 1

Fout 2

Mechanical Outline

0.517 [13.13] MAX

0.596 [15.14] MAX

PIN 1

0.150 [3.80] MAX

0.050 [1.27] NOM.TYP

0.100 [2.54] NOM.TYP

Pin #	Description
1	Fin
2	N/C
3	Sel
4	Vcc
5	Gnd
6	Fout 2
7	Fout 1
8	N/C
9	Vcc
10	Gnd

Table 1

Sel	Input Frequency (MHz)	Output Frequency (MHz)
0	25.00 MHz	25.00
1	Free-run Mode	25.00

