

VFJA905

Jitter Attenuator with 3 Input Selections plus Free-run Mode

Features

- 10 MHz to 200MHz Output Frequency Range
- 8 KHz to 200 MHz Input Frequency Range
- Ultra Low Jitter and Phase Noise: -143 dBc/Hz @ 1KHz
- Low Power: < 150mW typical

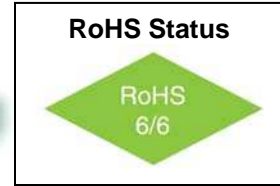
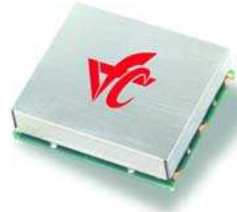

Applications

- Sonet / SDH / ATM
- 10 Gigabit Ethernet
- Wireless Infrastructure

Description

The VFJA905 is a Jitter Attenuator that provides two LVCMOS outputs with a frequency of 25 MHz. Two select inputs [S1,S0] allow the user to select 1 of 3 preset input frequencies or Free-run Mode. In Free-run mode the device outputs a 25 MHz clock that is not locked to the input reference frequency. Operating with a +3.3 volt power supply the device typically consumes 150 mW. The VFJA905 is available in a 19.5 mm x 15.5 mm surface mount package.

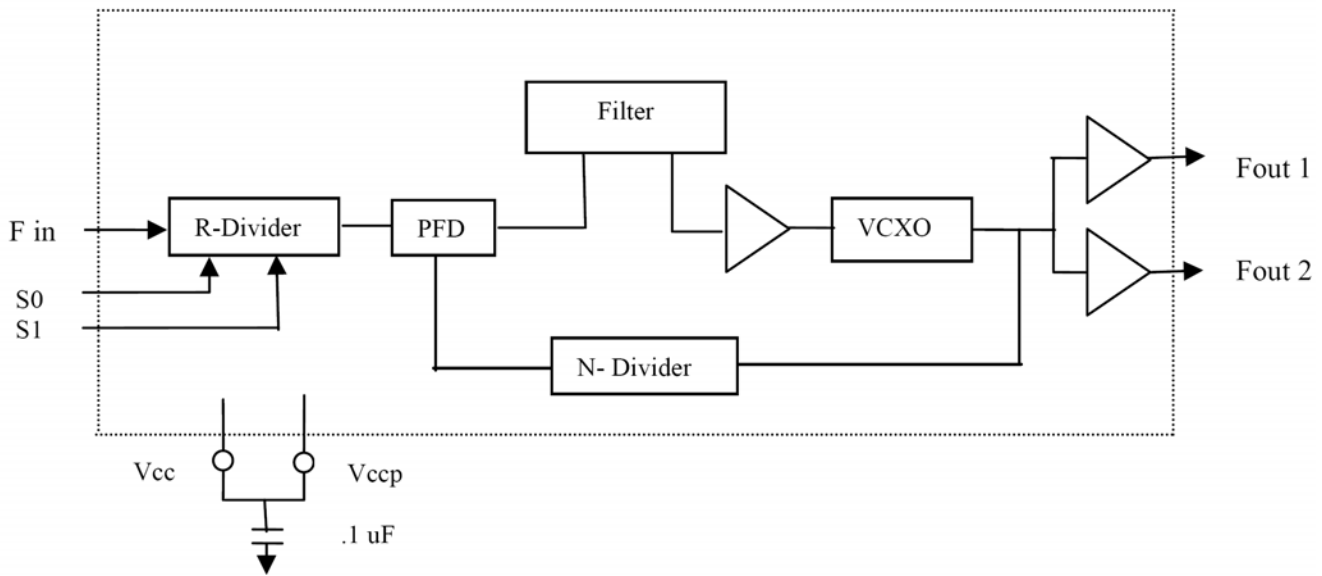

Block Diagram

VFJA905

Jitter Attenuator with 3 Input Selections plus Free-run Mode



Absolute Maximum Ratings

Parameter	Symbol	Condition	Min	Typ	Max	Unit	Note
Supply Break Down Voltage	Vcc		-0.5		5.5	V	
Storage Temperature	Ts		-55		+105°	°C	

Electrical Specifications

Parameter	Symbol	Condition	Min	Typ	Max	Unit	Note
Output Frequency Range	Fout			25		MHz	
Input Frequency Range	Fin	Slew Rate 2.5V / ns (min)		2.5 25 125		MHz	See Table 1
Input Level	Vin	AC coupled internally	0.4		3.3	V p-p	
Output Level Logic "1"	Voh	I _{OH} = 8 mA	Vcc-0.6		Vcc	V	
Output Level Logic "0"	Vol	I _{OL} = 8 mA	0.0		0.3	V	
Phase Jitter		12KHz to 20MHz		0.20	0.24	ps(rms)	
SSB Phase Noise	Φ _n	100Hz 1KHz 10KHz 100KHz		-120 -143 -153 -163		dBc/Hz	@ 25 MHz
APR			± 32			ppm	
Free-run Accuracy		-40°C to +85°C			±35	ppm	
Modulation BW			10			Hz	Note 1
Duty Cycle		@ 50%	45	50	55	%	
Rise / Fall Time	Tr/Tf	20% to 80%			0.6	ns	
Start up time				3		sec	
Supply Voltage	Vcc		3.15	3.30	3.45	V	
Input Current	Icc			45	55	mA	
Operating Temperature Range	Ta		-40°		+85°	°C	

Note : 1. Consult Factory for optional bandwidths.

VFJA905

Jitter Attenuator with 3 Input Selections plus Free-run Mode



Environmental and Mechanical

Parameter	Specification
Mechanical Shock	Per MIL-STD-202, Method 213, Condition E
Thermal Shock	Per MIL-STD-883, Method 1011, Condition A
Vibration	Per MIL-STD-883, Method 2007, Condition A
Soldering Conditions	260°C for 10s max
Hermetic Seal	Leak rate less than 5×10^{-8} atm.cc/s of helium (crystal only)

Connection Diagram

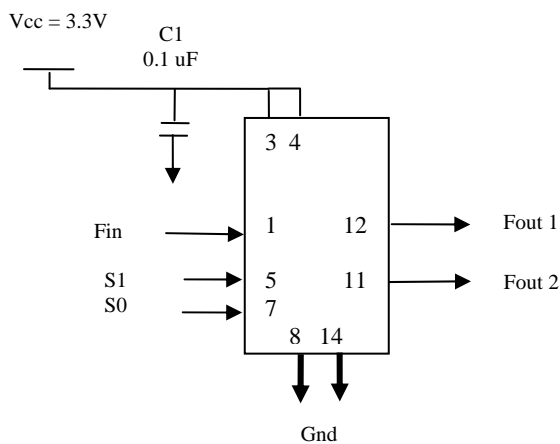

Pin #	Description
1	Fin
2	DNC
3	Vccp*
4	Vcc
5	S1
6	DNC
7	S0
8	Gnd
9	N/C
10	N/C
11	Fout 2
12	Fout 1
13	N/C
14	Gnd

* Connect pin #3 to pin #4 and add 0.1 uF

Mechanical Outline

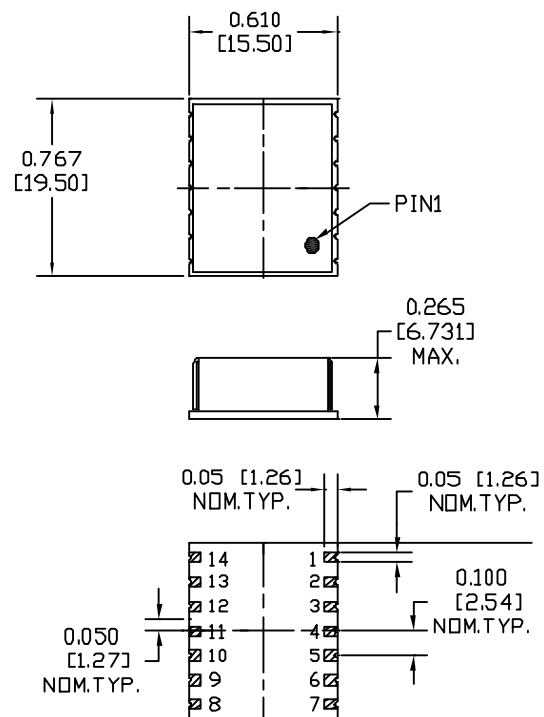

Table 1

S1:S0	Input Frequency (MHz)	Output Frequency (MHz)
00	Free-run Mode	25.00
01	2.5	25.00
10	25	25.00
11	125	25.00