

VFJA432

Quad Input to 200MHz

Jitter Attenuator w/ F_{OUT} to 200MHz



Features

- 10MHz to 200MHz Output Frequency Range
- 8KHz to 200MHz Input Frequency Range
- Ultra Low Jitter and Phase Noise: -143 dBc/Hz @ 1KHz
- Low Power: < 150mW typical
- Compliant with Telcordia GR-253-CORE, GR-1244-CORE, ITU-T G.813, and ITU-T G.8261

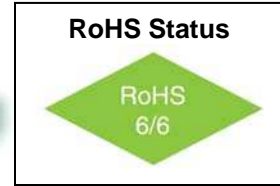
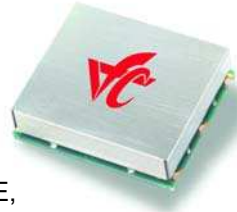

Applications

- SONET / SDH / ATM
- Carrier Ethernet Synchronizers
- Wireless Infrastructure

Description

The VFJA432 is a Jitter Attenuator capable of providing an output frequency up to 200MHz. Two select inputs [S1,S0] allow the user to select 1 of 4 preset input frequencies. A Lock Detect signal indicates when the output signal is frequency locked to the input. Operating with a +3.3 volt power supply the device typically consumes less than 150mW. The VFJA432 is configured with two LVCMOS output ports. The device is available in a 19.5mm x 15.5mm surface mount package.

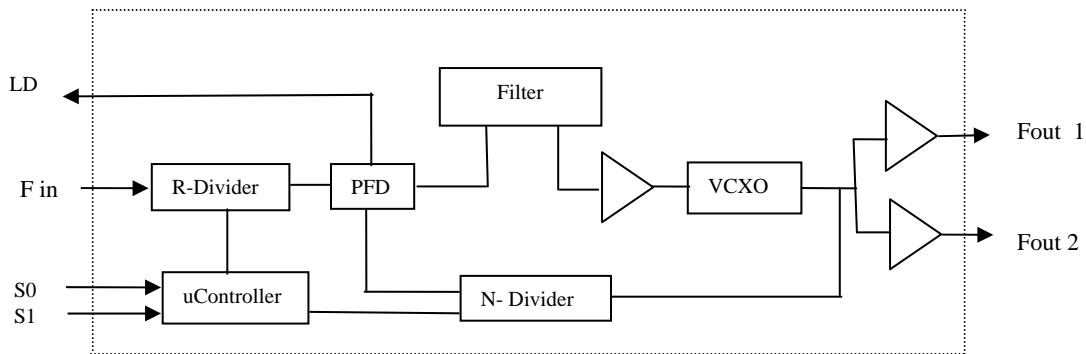

Block Diagram

VFJA432

Quad Input to 200MHz

Jitter Attenuator w/ F_{OUT} to 200MHz



Absolute Maximum Ratings

Parameter	Symbol	Condition	Min	Typ	Max	Unit	Note
Supply Break Down Voltage	V _{cc}		-0.5		5.5	V	
Storage Temperature	T _s		-55		+105°	°C	

Electrical Specifications

Parameter	Symbol	Condition	Min	Typ	Max	Unit	Note	
Output Frequency Range	F _{out}		10		200	MHz		
Input Frequency Range	F _{in}		0.008		200	MHz		
Input Level	V _{in}	AC coupled internally	0.4		3.3	V p-p		
Output Level Logic "1"	V _{oh}	10K Ω // 10 pF	V _{cc} -0.1		V _{cc}	V		
Output Level Logic "0"	V _{ol}		0.0		.1	V		
Phase Jitter		12KHz to 20MHz		0.18	0.35	ps(rms)		
SSB Phase Noise	Φ _n	100Hz 1KHz 10KHz 100KHz		-120 -143 -153 -163		dBc/Hz	@ 25 MHz	
APR			± 32			ppm		
Modulation BW			10			Hz	Note 1	
Duty Cycle		@ 50%	45	50	55	%		
Rise / Fall Time	T _r /T _f	20% to 80%	.8		4.0	ns		
Start up time				2	10	ms		
Supply Voltage	V _{cc}		3.15	3.30	3.45	V		
Input Current	I _{cc}			45	55	mA		
Operating Temperature Range	T _a		-40°		+85°	°C		
Lock Detect	LD	Output HIGH (> 2.5 V) : In Lock; Output LOW (< .5V): Out of Lock						LVC MOS

Notes:

1. Consult factory for Bandwidth options

VFJA432

Quad Input to 200MHz

Jitter Attenuator w/ F_{OUT} to 200MHz



Environmental and Mechanical

Parameter	Specification
Mechanical Shock	Per MIL-STD-202, Method 213, Condition E
Thermal Shock	Per MIL-STD-883, Method 1011, Condition A
Vibration	Per MIL-STD-883, Method 2007, Condition A
Soldering Conditions	260°C for 10s max
Hermetic Seal	Leak rate less than 5x10 ⁻⁸ atm.cc/s of helium (crystal only)

Pin Assignments

Pin #	Symbol	Description	Notes
1	Fin	Input Frequency	
2	LD	Lock Detect	
3	Vccp	Connect to Vcc pin #4	Add .1 uF Capacitor
4	Vcc	3.3 Volt Power Supply	
5	S1	Input Select (msb)	
6	DNC	Do not connect	
7	S0	Input Select (lsb)	
8	Gnd	Ground	
9	n/c	No connection	
10	n/c	No connection	
11	Fout 1	Output Frequency	
12	Fout 2	Output Frequency	
13	n/c	No connection	
14	Gnd	Ground	

How to Order

VFJA432 — Suffix

Once Input and Output frequencies have been submitted and approved, the Factory will assign a part number.

Table 2

P/N suffix	S1:S0	Input Frequency (MHz)	Output Frequency (MHz)	P/N suffix	S1:S0	Input Frequency (MHz)	Output Frequency (MHz)
-001	00	.008	25.00	-002	00	.008	125.00
	01	19.44	25.00		01	19.44	125.00
	10	25	25.00		10	25	125.00
	11	125	25.00		11	125	125.00
-003	00	10	16	-004	00	1	10.00
	01	10	16		01	2	10.00
	10	10	16		10	5	10.00
	11	10	16		11	10	10.00

VFJA432

Quad Input to 200MHz

Jitter Attenuator w/ F_{OUT} to 200MHz



Connection Diagram

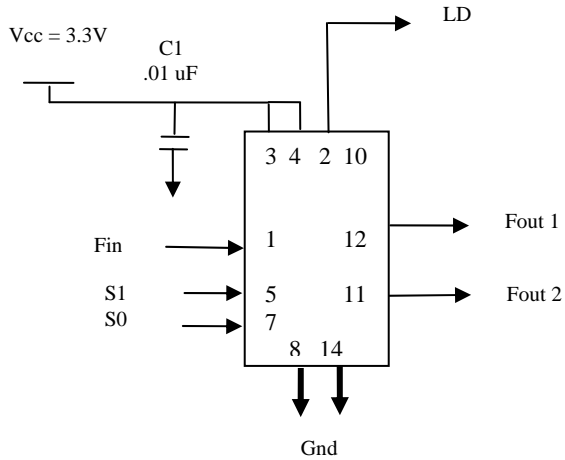

Mechanical Outline

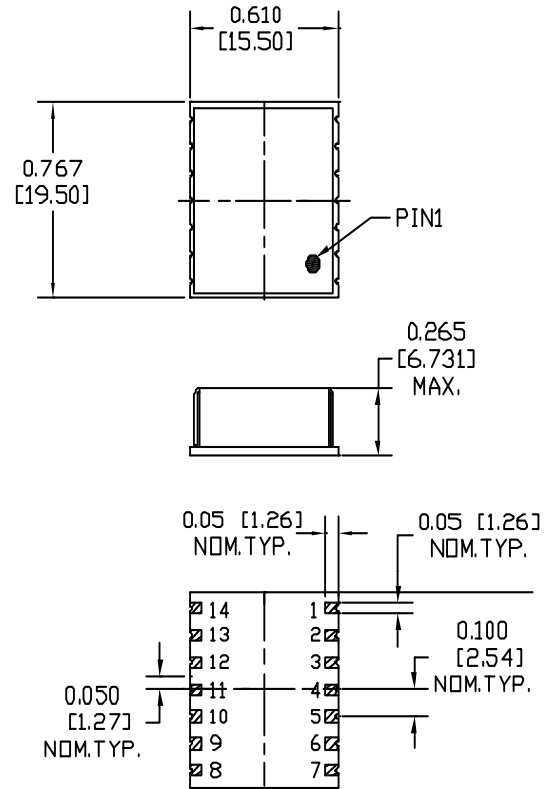

Recommended Pad Layout

