

# MR27V6454G

4M-Word × 16-Bit Page Mode **P2ROM**

## FEATURES

- 4,194,304-word × 16-bit configuration
- Page size of 8-word x 16-Bit
- 3.0 V to 3.6 V power supply
- Random Access time..... 100 ns MAX
- Page Access time ..... 30 ns MAX
- Operating current ..... 50 mA MAX (5MHz)
- Standby current ..... 10 µA MAX
- Input/Output TTL compatible
- Three-state output

## PACKAGES

- MR27V6454G-xxxTN  
48-pin plastic TSOP (TSOP I 48-P-1220-0.50-1K)

## P2ROM ADVANCED TECHNOLOGY

P2ROM stands for Production Programmed ROM. This exclusive LAPIS Semiconductor technology utilizes factory test equipment for programming the customers code into the P2ROM prior to final production testing.

Advancements in this technology allows production costs to be equivalent to MASKROM and has many advantages and added benefits over the other non-volatile technologies, which include the following;

- **Short lead time**, since the P2ROM is programmed at the final stage of the production process, a large P2ROM inventory "bank system" of un-programmed packaged products are maintained to provide an aggressive lead-time and minimize liability as a custom product.
- **No mask charge**, since P2ROMs do not utilize a custom mask for storing customer code, no mask charges apply.
- **No additional programming charge**, unlike Flash and OTP that require additional programming and handling costs, the P2ROM already has the code loaded at the factory with minimal effect on the production throughput. The cost is included in the unit price.
- **Custom Marking is** available at no additional charge.
- **Pin Compatible with Mask ROM** and some FLASH products.

## PIN CONFIGURATION (TOP VIEW)

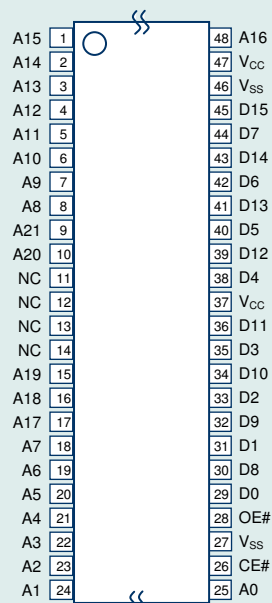

48TSOP(Type-I)

## BLOCK DIAGRAM

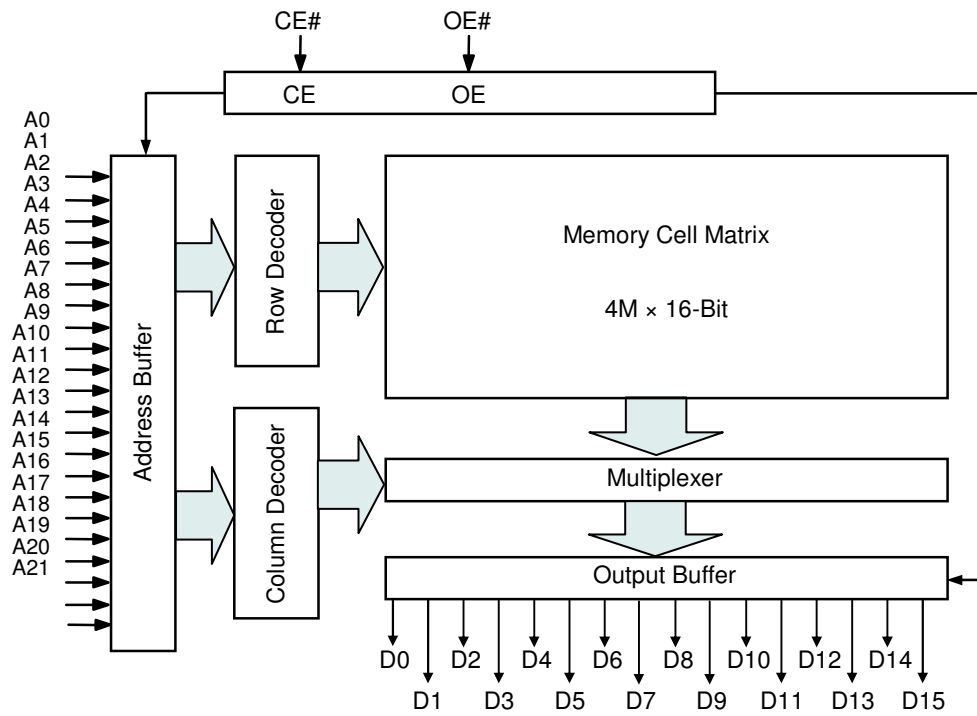

## PIN DESCRIPTIONS

Pin name	Functions
A0 to A21	Address inputs
D0 to D15	Data outputs
CE#	Chip enable input
OE#	Output enable input
V <sub>CC</sub>	Power supply voltage
V <sub>SS</sub>	Ground
NC	No connect

**FUNCTION TABLE**

Mode	CE#	OE#	V <sub>CC</sub>	D0 to D15
Read	L	L	3.3 V	Dout
Output disable	L	H		Hi-Z
Standby	H	*		Hi-Z

\*: Don't Care (H or L)

**ABSOLUTE MAXIMUM RATINGS**

Parameter	Symbol	Condition	Value	Unit
Operating temperature under bias	T <sub>a</sub>	—	0 to 70	°C
Storage temperature	T <sub>stg</sub>		-55 to 125	°C
Input voltage	V <sub>I</sub>	relative to V <sub>SS</sub>	-0.5 to V <sub>CC</sub> +0.5	V
Output voltage	V <sub>O</sub>		-0.5 to V <sub>CC</sub> +0.5	V
Power supply voltage	V <sub>CC</sub>		-0.5 to 5	V
Power dissipation per package	P <sub>D</sub>	T <sub>a</sub> = 25°C	1.0	W
Output short circuit current	I <sub>OS</sub>	—	10	mA

**RECOMMENDED OPERATING CONDITIONS**(T<sub>a</sub> = 0 to 70°C)

Parameter	Symbol	Condition	Min.	Typ.	Max.	Unit
V <sub>CC</sub> power supply voltage	V <sub>CC</sub>	V <sub>CC</sub> = 3.0 to 3.6 V	3.0	—	3.6	V
Input "H" level	V <sub>IH</sub>		2.2	—	V <sub>CC</sub> +0.5*	V
Input "L" level	V <sub>IL</sub>		-0.5**	—	0.6	V

Voltage is relative to V<sub>SS</sub>.\* : V<sub>CC</sub>+1.5V (Max.) when pulse width of overshoot is less than 10ns.

\*\* : -1.5V (Min.) when pulse width of undershoot is less than 10ns.

**PIN CAPACITANCE**(V<sub>CC</sub> = 3.3 V, T<sub>a</sub> = 25°C, f = 1 MHz)

Parameter	Symbol	Condition	Min.	Typ.	Max.	Unit
Input	C <sub>IN1</sub>	V <sub>I</sub> = 0 V	—	—	8	pF
Output	C <sub>OUT</sub>	V <sub>O</sub> = 0 V	—	—	10	



**TIMING CHART (READ CYCLE)**

**RANDOM ACCESS MODE READ CYCLE**

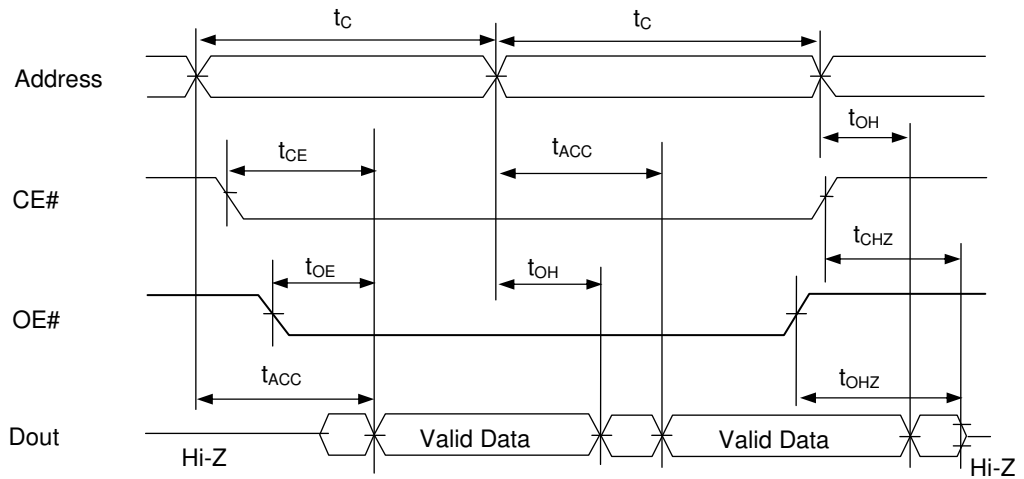

**PAGE ACCESS MODE READ CYCLE**

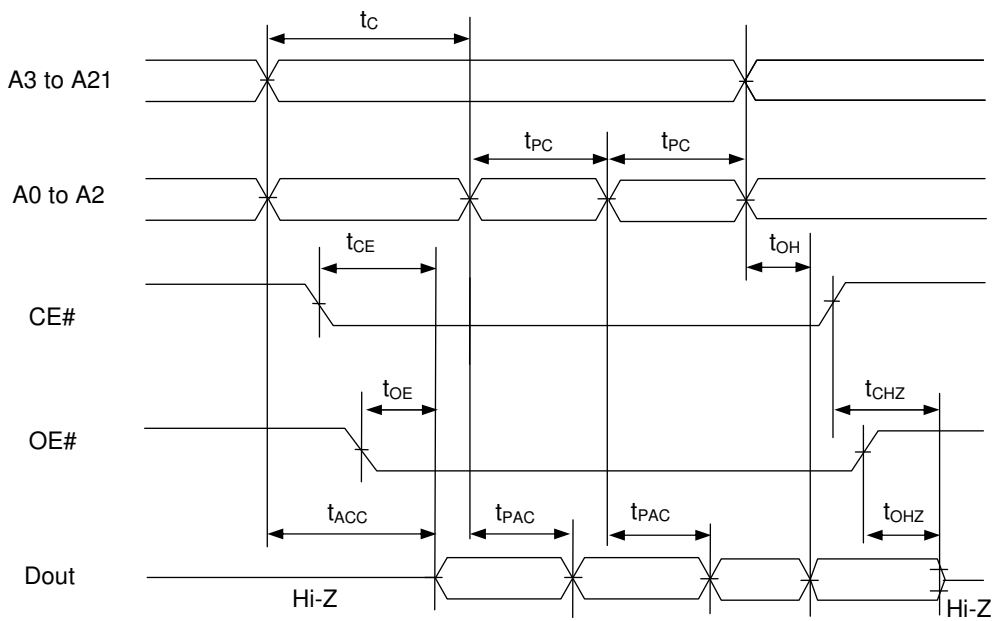

**PACKAGE DIMENSIONS**

(Unit: mm)

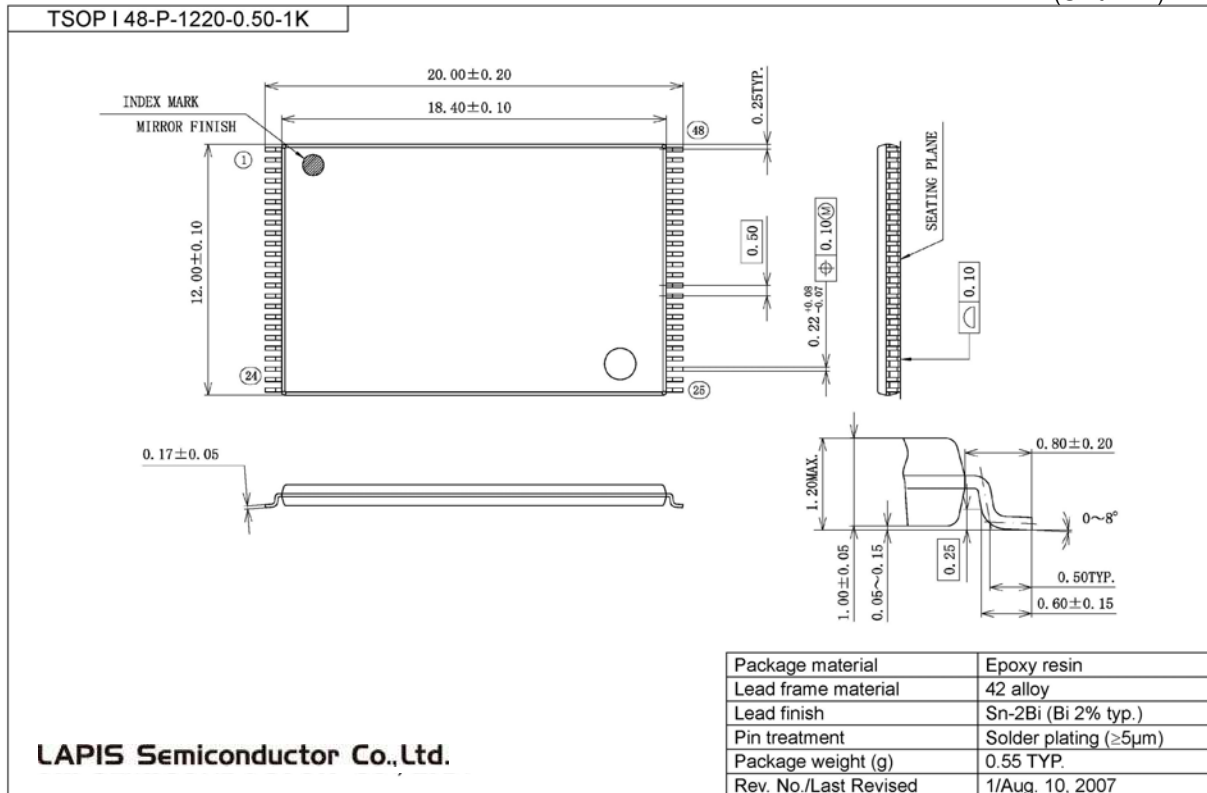

**Notes for Mounting the Surface Mount Type Package**

The surface mount type packages are very susceptible to heat in reflow mounting and humidity absorbed in storage.

Therefore, before you perform reflow mounting, contact LAPIS Semiconductor's responsible sales person for the product name, package name, pin number, package code and desired mounting conditions (reflow method, temperature and times).

**REVISION HISTORY**

Document No.	Date	Page		Description
		Previous Edition	Current Edition	
FEDR27V6454G-02-01	Apr., 2003	–	–	Final edition 1
FEDR27V6454G-02-02	May., 2003	1	1	Change 48TSOP(1) package code to –1K
FEDR27V6454G-02-03	Jun. 4, 2003	1,4	1,4	Change $t_{ACC}$ , $t_{PAC}$ to 100ns,30ns
FEDR27V6454G-02-04	Jul. 16, 2003	4	4	Change $t_{CHZ}$ to 20ns
FEDR27V6454G-02-05	Jul. 9, 2004	3	3	Add $P_D$ condition and $I_{OS} = 10mA$
FEDR27V6454G-002-05	Oct.1, 2008	–	–	Changed company logo and name to OKI SEMICONDUCTOR

**NOTICE**

No copying or reproduction of this document, in part or in whole, is permitted without the consent of LAPIS Semiconductor Co., Ltd.

The content specified herein is subject to change for improvement without notice.

The content specified herein is for the purpose of introducing LAPIS Semiconductor's products (hereinafter "Products"). If you wish to use any such Product, please be sure to refer to the specifications, which can be obtained from LAPIS Semiconductor upon request.

Examples of application circuits, circuit constants and any other information contained herein illustrate the standard usage and operations of the Products. The peripheral conditions must be taken into account when designing circuits for mass production.

Great care was taken in ensuring the accuracy of the information specified in this document. However, should you incur any damage arising from any inaccuracy or misprint of such information, LAPIS Semiconductor shall bear no responsibility for such damage.

The technical information specified herein is intended only to show the typical functions of and examples of application circuits for the Products. LAPIS Semiconductor does not grant you, explicitly or implicitly, any license to use or exercise intellectual property or other rights held by LAPIS Semiconductor and other parties. LAPIS Semiconductor shall bear no responsibility whatsoever for any dispute arising from the use of such technical information.

The Products specified in this document are intended to be used with general-use electronic equipment or devices (such as audio visual equipment, office-automation equipment, communication devices, electronic appliances and amusement devices).

The Products specified in this document are not designed to be radiation tolerant.

While LAPIS Semiconductor always makes efforts to enhance the quality and reliability of its Products, a Product may fail or malfunction for a variety of reasons.

Please be sure to implement in your equipment using the Products safety measures to guard against the possibility of physical injury, fire or any other damage caused in the event of the failure of any Product, such as derating, redundancy, fire control and fail-safe designs. LAPIS Semiconductor shall bear no responsibility whatsoever for your use of any Product outside of the prescribed scope or not in accordance with the instruction manual.

The Products are not designed or manufactured to be used with any equipment, device or system which requires an extremely high level of reliability the failure or malfunction of which may result in a direct threat to human life or create a risk of human injury (such as a medical instrument, transportation equipment, aerospace machinery, nuclear-reactor controller, fuel-controller or other safety device). LAPIS Semiconductor shall bear no responsibility in any way for use of any of the Products for the above special purposes. If a Product is intended to be used for any such special purpose, please contact a ROHM sales representative before purchasing.

If you intend to export or ship overseas any Product or technology specified herein that may be controlled under the Foreign Exchange and the Foreign Trade Law, you will be required to obtain a license or permit under the Law.

Copyright 2008 - 2011 LAPIS Semiconductor Co., Ltd.