

Product Specification

8.5 Gb/s Short-Wavelength SFP+ Transceiver

FTLF8528P3BxV

PRODUCT FEATURES

- Up to 8.5 Gb/s bi-directional data links
- Hot-pluggable SFP+ footprint
- Built-in digital diagnostic functions
- 850nm Oxide VCSEL laser transmitter
- Duplex LC connector
- RoHS compliant and Lead Free
- 50m on 50/125µm MMF
- 150m on high-bandwidth 50/125um (OM3) MMF
- Metal enclosure, for lower EMI
- Single 3.3V power supply
- < 0.5W power dissipation
- Extended operating temperature range: -5°C to 85°C



APPLICATIONS

- Tri-Rate 2.125/4.25/8.5 Gb/s Fibre Channel
- Wireless – CPRI
- Wireless - OBSAI

Finisar's FTLF8528P3BxV SFP+ transceivers are designed for use in Fibre Channel links up to 8.5 Gb/s data rate over multimode fiber. They are compliant with FC-PI-4 Rev. 8.00^a and SFF-8472 Rev 11.0^c, and compatible with SFF-8432^b and applicable portions of SFF-8431 Rev. 4.1^d. The product is RoHS compliant and lead-free per Directive 2002/95/EC^e and Finisar Application Note AN-2038.

PRODUCT SELECTION

FTLF8528P3BxV

x	N	Extended Temperature, -5C to 85°C
	C	Commercial Temperature, -5 to 70°C

4. Pin Descriptions

Pin	Symbol	Name/Description	Ref.
1	V _{EET}	Transmitter Ground (Common with Receiver Ground)	1
2	T _{FAULT}	Transmitter Fault.	2
3	T _{DIS}	Transmitter Disable. Laser output disabled on high or open.	3
4	SDA	2-wire Serial Interface Data Line (MOD-DEF2)	4
5	SCA	2-wire Serial Interface Clock (MOD-DEF1)	4
6	MOD_ABS	Module Absent, connected to V _{EET} or V _{EER}	4
7	RS0	Rx Rate Select: Open or Low = 2.125 or 4.25 Gb/s Fibre Channel (Low Bandwidth) High = 8.5 Gb/s Fibre Channel (High Bandwidth)	5
8	LOS	Loss of Signal indication. Logic 0 indicates normal operation.	6
9	RS1	Tx Rate Select: Open or Low = 2.125 or 4.25 Gb/s Fibre Channel (Low Bandwidth) High = 8.5 Gb/s Fibre Channel (High Bandwidth)	5
10	V _{EER}	Receiver Ground (Common with Transmitter Ground)	1
11	V _{EER}	Receiver Ground (Common with Transmitter Ground)	1
12	RD-	Receiver Inverted DATA out. AC Coupled	
13	RD+	Receiver Non-inverted DATA out. AC Coupled	
14	V _{EER}	Receiver Ground (Common with Transmitter Ground)	1
15	V _{CCR}	Receiver Power Supply	
16	V _{CCT}	Transmitter Power Supply	
17	V _{EET}	Transmitter Ground (Common with Receiver Ground)	1
18	TD+	Transmitter Non-Inverted DATA in. AC Coupled.	
19	TD-	Transmitter Inverted DATA in. AC Coupled.	
20	V _{EET}	Transmitter Ground (Common with Receiver Ground)	1

Notes:

- Circuit ground is internally isolated from chassis ground.
- T_{FAULT} is an open collector/drain output, which should be pulled up with a 4.7k – 10k Ohms resistor on the host board if intended for use. Pull up voltage should be between 2.0V to V_{CC} + 0.3V. A high output indicates a transmitter fault caused by either the TX bias current or the TX output power exceeding the preset alarm thresholds. A low output indicates normal operation. In the low state, the output is pulled to <0.8V.
- Laser output disabled on T_{DIS} >2.0V or open, enabled on T_{DIS} <0.8V.
- Should be pulled up with 4.7k – 10kohms on host board to a voltage between 2.0V and 3.6V. MOD_ABS pulls line low to indicate module is plugged in.
- Rate select can also be set through the 2-wire bus in accordance with SFF-8472 v. 11.0°. Rx Rate Select is set at Bit 3, Byte 110, Address A2h. Tx Rate Select is set at Bit 3, Byte 118, Address A2h. Note: writing a “1” selects maximum bandwidth operation. Rate select is the logic OR of the input state of Rate Select Pin and 2-wire bus.
- LOS is open collector output. Should be pulled up with 4.7k – 10kohms on host board to a voltage between 2.0V and 3.6V. Logic 0 indicates normal operation; logic 1 indicates loss of signal.

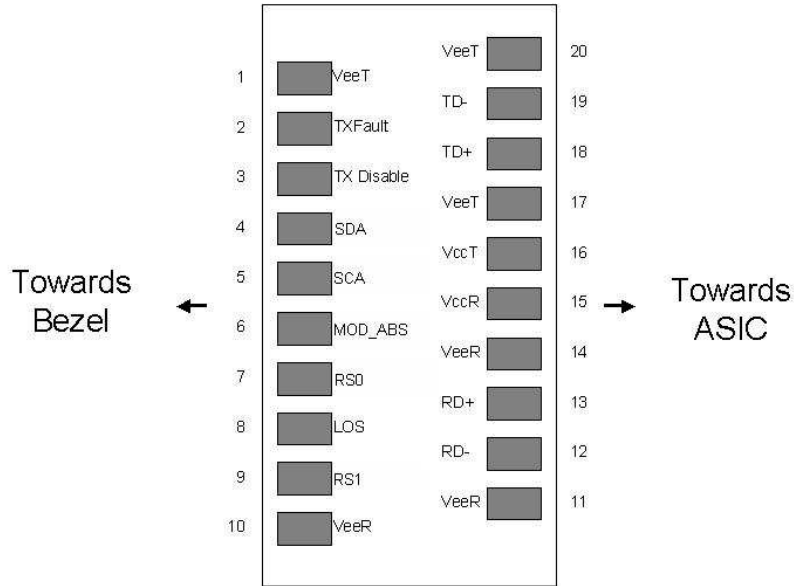

Diagram of Host Board Connector Block Pin Numbers and Names

4. Absolute Maximum Ratings

Parameter	Symbol	Min	Typ	Max	Unit	Ref.
Maximum Supply Voltage	Vcc	-0.5		4.0	V	
Storage Temperature	T _S	-40		85	°C	
Case Operating Temperature	T _A				°C	
Commercial Temperature		-5		70		
Extended Temperature		-5		85		
Relative Humidity (Non-condensing)	RH	0		85	%	

III. Electrical Characteristics (T_A, V_{CC} = 3.15 to 3.46 Volts)

Parameter	Symbol	Min	Typ	Max	Unit	Ref.
Supply Voltage	V _{CC}	3.15		3.45	V	
Supply Current	I _{CC}			180	mA	
Transmitter						
Input differential impedance	R _{in}		100		Ω	1
Single ended data input swing	V _{in,pp}	90		800	mV	
Transmit Disable Voltage	V _D	2		V _{CC}	V	2
Transmit Enable Voltage	V _{EN}	V _{EE}		V _{EE} +0.8	V	
Receiver						
Single ended data output swing RS='1'	V _{out,pp}	185		425	mV	3
Single ended data output swing RS='0'	V _{out,pp}	185		800	mV	3
Data Output Rise/Fall Time @ 2.125, 4.25 Gb/s	t _r / t _f			120	ps	4
Data Output Rise/Fall Time @ 8.5 Gb/s	t _r / t _f			60	ps	4
LOS Fault	V _{LOS fault}	2		V _{CCHOST}	V	5
LOS Normal	V _{LOS norm}	V _{EE}		V _{EE} +0.8	V	5
Power Supply Rejection	PSR	100			mVpp	6
Deterministic Jitter Contribution @ 2.125 Gb/s	RX Δ DJ			47.1	ps	
Total Jitter Contribution @ 2.125 Gb/s	RX Δ TJ			123.5	ps	7
Deterministic Jitter Contribution @ 4.25 Gb/s	RX Δ DJ			23.5	ps	
Total Jitter Contribution @ 4.25 Gb/s	RX Δ TJ			61.8	ps	8
Deterministic Jitter @ 8.5 Gb/s	RX DJ			49.4	ps	8
Pulse Width Shrinkage @ 8.5 Gb/s	RX DDPWS			42.4	ps	8
Total Jitter @ 8.5 Gb/s	RX TJ			83.5	ps	8

Notes:

1. Connected directly to TX data input pins. AC coupling from pins into laser driver IC.
2. Or open circuit.
3. Into 100 ohms differential termination.
4. Unfiltered, 20 – 80 %
5. LOS is an open collector output. Should be pulled up with 4.7k – 10kohms on the host board. Normal operation is logic 0; loss of signal is logic 1. Maximum pull-up voltage is 5.5V.
6. Receiver sensitivity is compliant with power supply sinusoidal modulation of 20 Hz to 1.5 MHz up to specified value applied through the recommended power supply filtering network.
7. If measured with TJ-free data input signal. In actual application, output TJ will be given by:

$$TJ_{OUT} = DJ_{IN} + \Delta DJ + \sqrt{(TJ_{IN} - DJ_{IN})^2 + (\Delta TJ - \Delta DJ)^2}$$

8. As defined in FC-PI-4¹, Rev 8.0, Table 12, 800-Mx-SN-y.

VI. Optical Characteristics (T_A, V_{CC} = 3.15 to 3.46 Volts)

Parameter	Symbol	Min	Typ	Max	Unit	Ref.
Transmitter						
Output Opt. Pwr: 50 or 62.5 MMF	P _{OUT}	-8.2		-2	dBm	1
Optical Wavelength	λ	840		860	nm	
Spectral Width	σ			0.65	nm	
Optical Modulation Amplitude @ 2.125 Gb/s	OMA	196			μW	
Optical Modulation Amplitude @ 4.25 Gb/s	OMA	247			μW	
Optical Modulation Amplitude @ 8.5 Gb/s	OMA	302			μW	
Optical Rise/Fall Time @ 2.125, 4.25 Gb/s	t _r / t _f			90	ps	2
Transmitter Waveform and Dispersion Penalty @ 8.5 Gb/s	TWDP			4.2	dB	3
Relative Intensity Noise	RIN			-128	dB/Hz	
Deterministic Jitter Contribution @ 2.125 Gb/s	TX Δ DJ			56.5	ps	
Total Jitter Contribution @ 2.125 Gb/s	TX Δ TJ			119.6	ps	4
Deterministic Jitter Contribution @ 4.25 Gb/s	TX Δ DJ			28.2	ps	
Total Jitter Contribution @ 4.25 Gb/s	TX Δ TJ			59.8	ps	4
Receiver						
Receiver OMA Sensitivity = 2.125 Gb/s	R _x SENS			49	μW	
Receiver OMA Sensitivity = 4.25 Gb/s	R _x SENS			61	μW	
Receiver OMA Sensitivity = 8.5 Gb/s	R _x SENS			76	μW	
Average Receiver Power	R _x MAX	0			dBm	
Optical Center Wavelength	λ _C	770		860	nm	
Optical Return Loss		12			dB	
LOS De-Assert	LOS _D			-18	dBm	
LOS Assert	LOS _A	-30			dBm	
LOS Hysteresis		0.5			dB	

Notes:

- Class 1 Laser Safety per FDA/CDRH, and EN (IEC) 60825 laser safety standards.
- Unfiltered, 20-80%. Complies with FC 1x and 2x eye mask when filtered.
- TWDP is calculated with a 1,0 equalizer and a 6,860 MHz Gaussian filter for the fiber simulation. Jitter values at γ_T and γ_R are controlled by TWDP and stress receiver sensitivity.
- If measured with TJ-free data input signal. In actual application, output TJ will be given by:

$$TJ_{OUT} = DJ_{IN} + \Delta DJ + \sqrt{(TJ_{IN} - DJ_{IN})^2 + (\Delta TJ - \Delta DJ)^2}$$

VI. General Specifications

Parameter	Symbol	Min	Typ	Max	Units	Ref.
Data Rate	BR		2.125 4.25 8.5		Gb/sec	1
Bit Error Rate	BER			10 ⁻¹²		2
Fiber Length on 50/125µm MMF	L			300 150 50	m	3 4 5
Fiber Length on 50/125µm high-bandwidth (OM3) MMF	L			500 380 150	m	3 4 5

Notes:

1. 2x and 4x Fibre Channel compatible, per FC-PI-4¹.
2. PRBS 2⁷-1.
3. At 2.125 Gb/s Fibre Channel data rate.
4. At 4.25 Gb/s Fibre Channel data rate.
5. At 8.5 Gb/s Fibre Channel data rate.

VI. Environmental Specifications

Parameter	Symbol	Min	Typ	Max	Units	Ref.
Case Operating Temperature	T _{op}				°C	
Commercial Temperature		-5		70		
Extended Temperature		-5		85		
Storage Temperature	T _{sto}	-40		85	°C	

VII. Regulatory Compliance

Finisar transceivers are Class 1 Laser Products and comply with US FDA regulations. These products are certified by TÜV and CSA to meet the Class 1 eye safety requirements of EN (IEC) 60825. Copy of certificate is available at Finisar Corporation upon request.

VIII. Digital Diagnostic Functions

Finisar FTLF8528P3BxV SFP+ transceivers support the 2-wire serial communication protocol as defined in the SFP MSA^f. It is very closely related to the E²PROM defined in the GBIC standard, with the same electrical specifications.

The standard SFP serial ID provides access to identification information that describes the transceiver's capabilities, standard interfaces, manufacturer, and other information.

Additionally, Finisar SFP transceivers provide an enhanced digital diagnostic monitoring interface, which allows real-time access to device operating parameters such as transceiver temperature, laser bias current, transmitted optical power, received optical power and transceiver supply voltage. It also defines a sophisticated system of alarm and warning flags, which alerts end-users when particular operating parameters are outside of a factory set normal range.

The SFP MSA defines a 256-byte memory map in E²PROM that is accessible over a 2-wire serial interface at the 8 bit address 1010000X (A0h). The digital diagnostic monitoring interface makes use of the 8 bit address 1010001X (A2h), so the originally defined serial ID memory map remains unchanged. The interface is identical to, and is thus fully backward compatible with both the GBIC Specification and the SFP Multi Source Agreement. The complete interface is described in Finisar Application Note AN-2030: "Digital Diagnostics Monitoring Interface for SFP Optical Transceivers".

The operating and diagnostics information is monitored and reported by a Digital Diagnostics Transceiver Controller (DDTC) inside the transceiver, which is accessed through a 2-wire serial interface. When the serial protocol is activated, the serial clock signal (SCL, Mod Def 1) is generated by the host. The positive edge clocks data into the SFP transceiver into those segments of the E²PROM that are not write-protected. The negative edge clocks data from the SFP transceiver. The serial data signal (SDA, Mod Def 2) is bi-directional for serial data transfer. The host uses SDA in conjunction with SCL to mark the start and end of serial protocol activation. The memories are organized as a series of 8-bit data words that can be addressed individually or sequentially.

For more information, please see the SFP MSA documentation^{cf} and Finisar Application Note AN-2030.

Please note that evaluation board FDB-1027 is available with Finisar ModDEMO software that allows simple to use communication over the 2-wire serial interface.

IX. Digital Diagnostic Specifications

FTLF8528P3BxV transceivers can be used in host systems that require either internally or externally calibrated digital diagnostics.

Parameter	Symbol	Min	Typ	Max	Units	Ref.
Accuracy						
Internally measured transceiver temperature	DD _{Temperature}			3	°C	
Internally measured transceiver supply voltage	DD _{Voltage}			100	mV	
Measured TX bias current	DD _{Bias}			10	%	1
Measured TX output power	DD _{Tx-Power}			2	dB	
Measured RX received average optical power	DD _{Rx-Power}			2	dB	
Dynamic Range for Rated Accuracy						
Internally measured transceiver temperature	DD _{Temperature}	-5		85	°C	
Internally measured transceiver supply voltage	DD _{Voltage}	3.0		3.6	V	
Measured TX bias current	DD _{Bias}	0		20	mA	
Measured TX output power	DD _{Tx-Power}	-9		-2	dBm	
Measured RX received average optical power	DD _{Rx-Power}	-18		0	dBm	
Max Reporting Range						
Internally measured transceiver temperature	DD _{Temperature}	-40		125	°C	
Internally measured transceiver supply voltage	DD _{Voltage}	2.8		4.0	V	
Measured TX bias current	DD _{Bias}	0		20	mA	
Measured TX output power	DD _{Tx-Power}	-10		-2	dBm	
Measured RX received average optical power	DD _{Rx-Power}	-20		0	dBm	

Notes:

1. Accuracy of Measured Tx Bias Current is 10% of the actual Bias Current from the laser driver to the laser.

X. Mechanical Specifications

Finisar’s FTLF8528P3BxV SFP+ transceivers are compatible with the SFF-8432² specification for improved pluggable form factor.

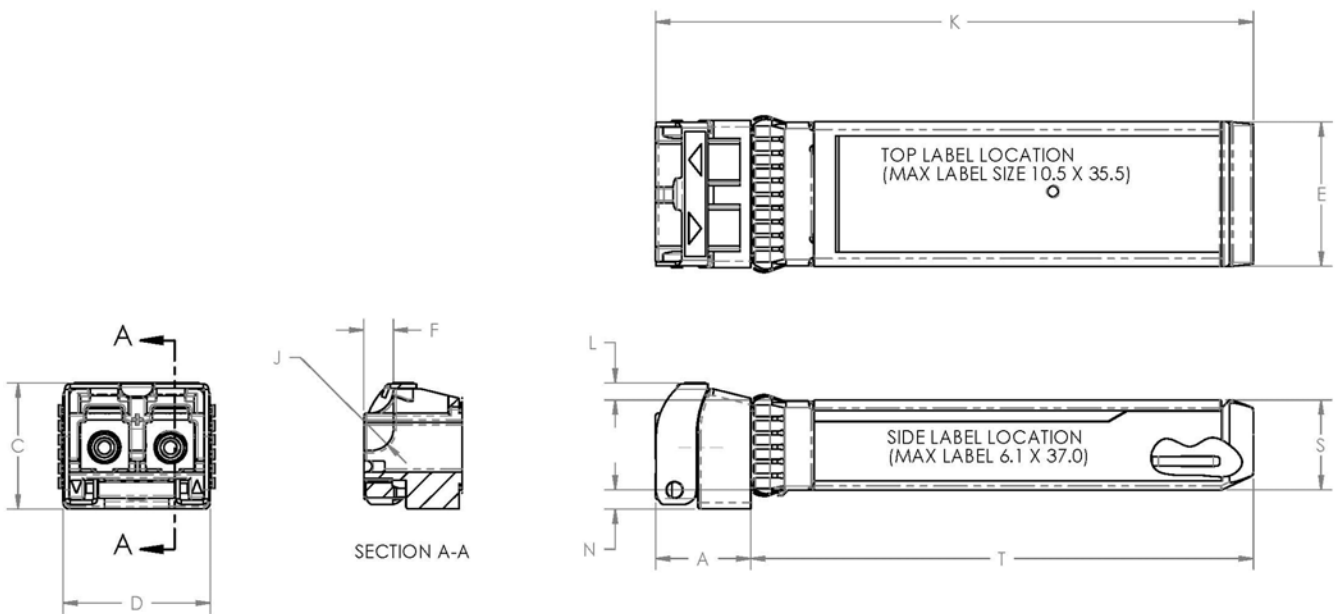

ITEM	DIM (mm)	TOL (mm)
A	9.00	± 0.3
C	11.90	± 0.5
D	13.85	± 0.15
E	13.65	± 0.15
F	2.80	± 0.2
J	2.00	± 0.2
K	56.50	REF
L	1.60	± 0.5
N	1.80	± 0.1
S	8.55	± 0.15
T	47.50	± 0.2

FTLF8528P3BxV

XI. PCB Layout and Bezel Recommendations

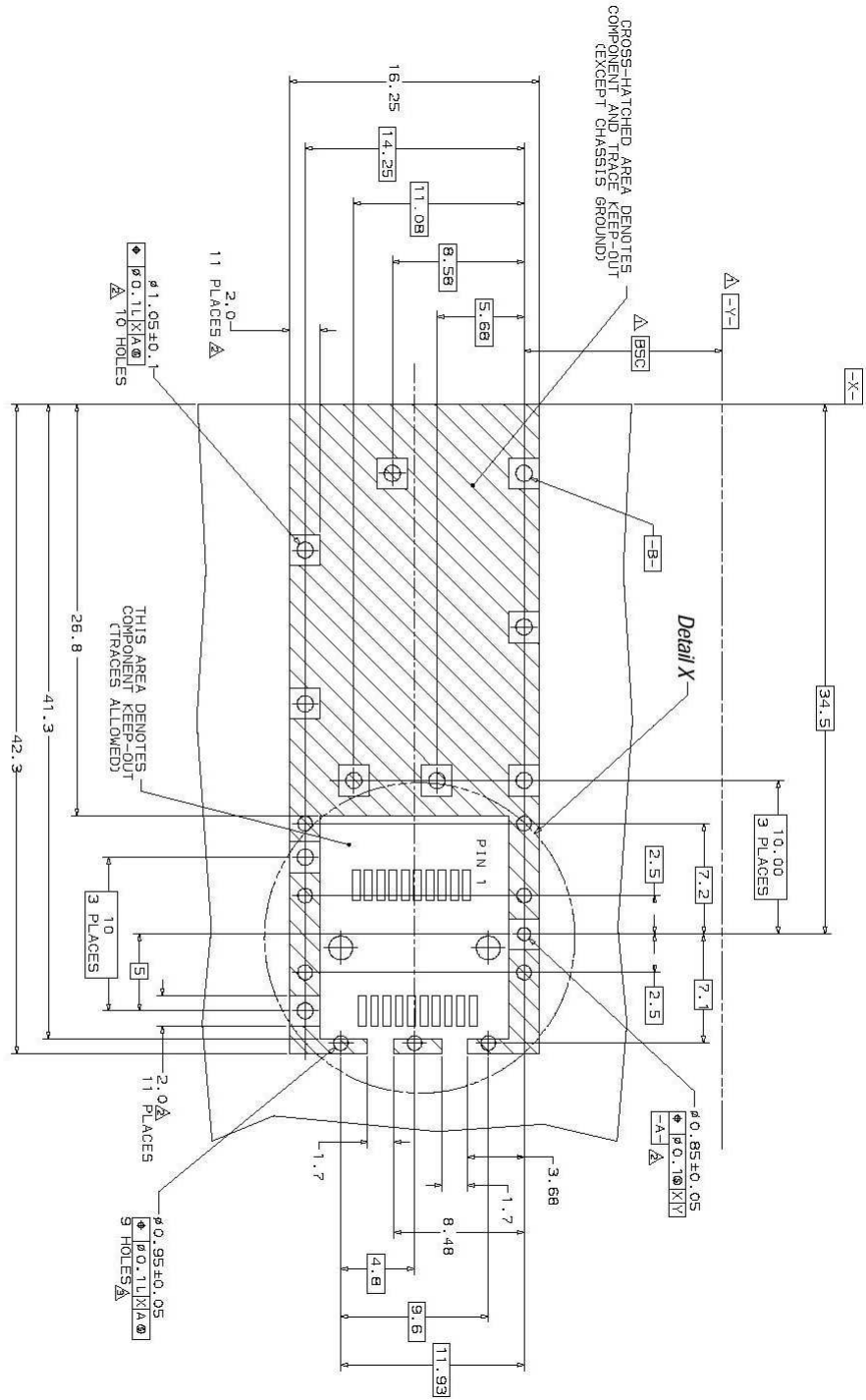

- Δ Datum and Basic Dimension Established by Customer
- ∇ Rads and Vias are Chassis Ground, 11 Places
- ∇ Through Holes are Unplated

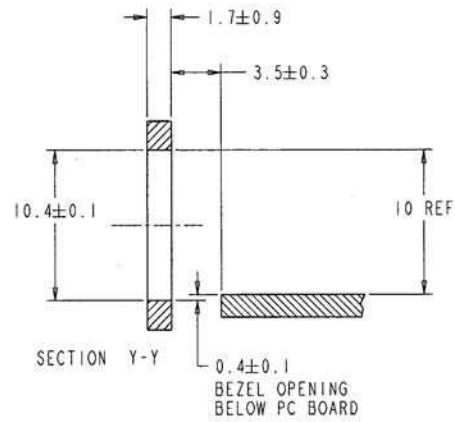
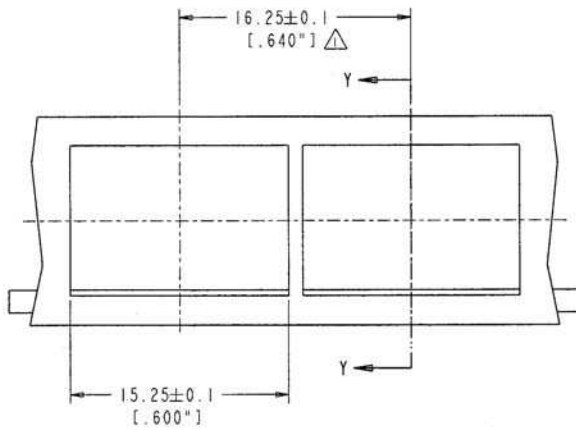
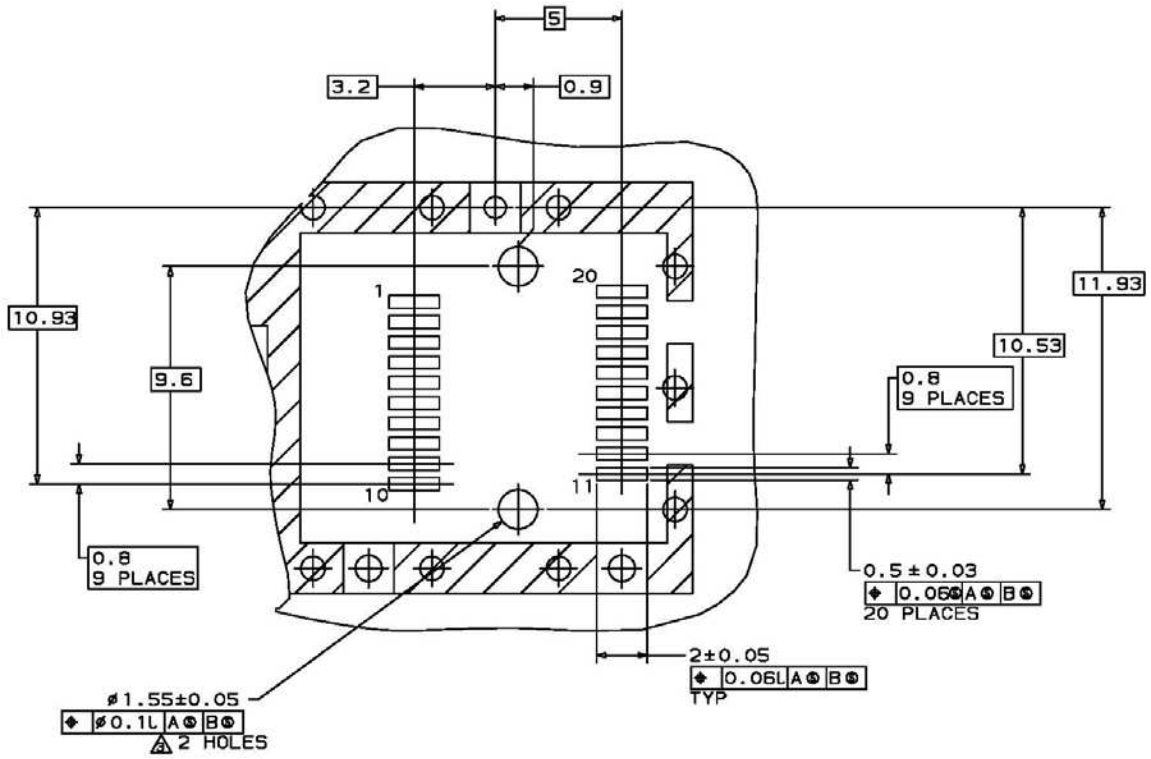

- NOTES:
- △ MINIMUM PITCH ILLUSTRATED, ENGLISH DIMENSIONS ARE FOR REFERENCE ONLY
 - 2. NOT RECOMMENDED FOR PCI EXPANSION CARD APPLICATIONS

XII. References

- a. “Fibre Channel Physical Interface-4 Specification (FC-PI-4 Rev. 8.00)”. American National Standard for Information Systems, May 21, 2008.
- b. “Improved Pluggable Form Factor”, SFF Document Number SFF-8432, Revision 5.0, July 16, 2007.
- c. “Digital Monitoring Interface for Optical Transceivers”, SFF Document Number SFF-8472, Revision 11.0.
- d. “SFF-8431 Specifications for Enhanced Small Form Factor Pluggable Modules, SFP+”, SFF Document Number SFF-8431, Revision 4.1, July 6, 2009.
- e. Directive 2002/95/EC of the European Council Parliament and of the Council, “on the restriction of the use of certain hazardous substances in electrical and electronic equipment.” January 27, 2003.
- f. Small Form Factor Pluggable (SFP) Transceiver Multi-source Agreement (MSA), September 14, 2000.

XIII. For More Information

Finisar Corporation
1389 Moffett Park Drive
Sunnyvale, CA 94089-1133
Tel. 1-408-548-1000
Fax 1-408-541-6138
sales@finisar.com
www.finisar.com