

---

# ML9460

---

## Common Driver for Dot Matrix STN Liquid Crystal Display

---

### 1. Product Overview

#### 1.1 General Description

The ML9460 is a 240-output common driver for driving a dot matrix LCD panel. It enables switching between 240 outputs and 200 outputs and 160 outputs and 120 outputs. The ML9460 is used in combination with the segment driver ML9461B.

#### 1.2 Features

- 240-channel common driver
- Display duty: Up to 1/240
- LCD drive voltage: 43 V max.
- Operating voltage: 2.5 to 5.5 V
- Intermediate voltage Interface
- Built-in alternating signal generation circuit; pin programmable
- Built-in display OFF control circuit
- Can switch output modes: 240-output mode/200-output mode/160-output mode/120-output mode
- Clock cycle time: 245 ns min. @ 4.5 V 330 ns @ 2.5 V
- Package
  - Au Bump Chip      Product name: ML9460CVWA
  - TCP                    Product name: ML9460ADVVA

## 2. Pin Description

### 2.1 Pin Description

| Pin name                                  | I/O | Polarity | Description  | Initial value    | Handling when not used | Attribute | Remarks  |
|---|-----|----------|--|------------------|------------------------|-----------|--|
| VDD                                       | —   | —        | Logic power supply pin   | —                | —                      | Power     |  |
| VSS                                       | —   | —        | Logic power supply pin   | —                | —                      | VSS       |  |
| V2L<br>V2R                                | —   | —        | Power supply pins for liquid crystal drive level output. Selective level.  | —                | —                      | Power     | V2L and V2R are connected internally with each other.  |
| MV2L<br>MV2R                              | —   | —        | Power supply pins for liquid crystal drive level output. Selective level.  | —                | —                      | Power     | MV2L and MV2R are connected internally with each other.  |
| VCL<br>VCR                                | —   | —        | Power supply pins for liquid crystal drive level output. Nonselective level.   | —                | —                      | Power     | VCL and VCR are connected internally with each other.  |
| YSCL                                      | I   | ↓        | Shift clock input pin. Data is shifted in on the falling edge of the shift clock YSCL of the shift register.   | Low              | —                      | CLK       |  |
| FR  | I/O | —        | Input-output pin for alternating signal for liquid crystal drive output  | Low              | —                      | Digital   | See Sections 4.1.1, "Liquid Crystal Drive Circuit," and 4.2.1, "Timing of Connection with the Segment Driver." |
| FRWS0<br>FRWS1<br>FRWS2<br>FRWS3<br>FRWS4 | I   | —        | Alternating signal (FR signal) period setting pins. Specify the number of lines with an integer from 2 to 31. For operation using an external alternating signal, set the number of lines to 0.  | Tied High or Low | —                      | Digital   | See Sections 4.1.4, "Alternating Signal Generation Circuit."   |
| SEL1<br>SEL2                              | I   | —        | Liquid crystal drive output pin switching pins   | Tied High or Low | —                      | Digital   | See Sections 4.1.1, "Liquid Crystal Drive Circuit," and 4.1.3, "Bidirectional Shift Register."                 |
| DIO1<br>DIO2                              | I/O | —        | Serial I/O (shift register data input-output) pins   | Tied High or Low | —                      | Digital   | See Section 4.1.3, "Bidirectional Shift Register."   |
| $\overline{\text{FRRES}}$                 | I   | Negative | Pin for initializing the counter for the alternating signal generation circuit.<br><b>Setting this pin to "L" level sets initializes the alternating signal(FR signal) circuit. A "H" level <math>\overline{\text{FRRES}}</math> is normally used.</b> | Low              | —                      | Digital   |  |
| $\overline{\text{DSPOF}}$                 | I   | Negative | A "L" level on this pin sets each of the liquid crystal drive outputs O1–O240 to the VC level. No internal register will be cleared.   | Low              | —                      | Digital   |  |
| DSPMS                                     | I   | —        | Pin for selecting the method of processing the $\overline{\text{DSPOF}}$ signal internally   | Tied High or Low | —                      | Digital   | See Section 4.1.5, "Control Circuit."  |

| Pin name                | I/O | Polarity | Descripton   | Initial value    | Handling when not used  | Attribute | Remarks  |
|-------------------------|-----|----------|--|------------------|---|-----------|--|
| $\overline{\text{DOC}}$ | O   | Negative | DISPOFF signal output pin  | Low              | —   | Digital   | See Sections 4.1.5, "Control Circuit," and 4.2.3, " $\overline{\text{DOC}}$ Signal Waveforms." |
| SHL                     | I   | —        | Shift direction switching pin. Switches the shift direction of the shift register.   | Tied High or Low | —   | Digital   | See Section 4.1.3, "Bidirectional Shift Register."   |
| O1 to O240              | O   | —        | Liquid crystal drive output pins. When the VDD voltage is input to the $\overline{\text{DSPOF}}$ pin, one of the three levels (V2, MV2, VC) is selected and output according to the combination of the FR signal and display data. | —                | Pins that are made disabled by the SEL1 and SEL2 pins will output the nonselective level signal (VC). | Analog    | See Section 4.1.1, "Liquid Crystal Drive Circuit."   |

Note:

In the initial value column,

- A dash "—" for an input pin indicates that the initial value is Don't Care.
- A dash "—" for an output pin indicates that the initial value is undefined.

## 2.2 Input and Output Configuration

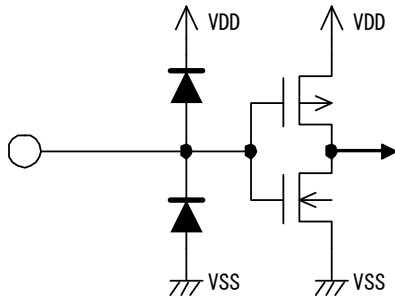

Applicable to pins YSCL, FRWS0~4, SEL1, SEL2, FRRES, DSPOF, DSPMS, and SHL.

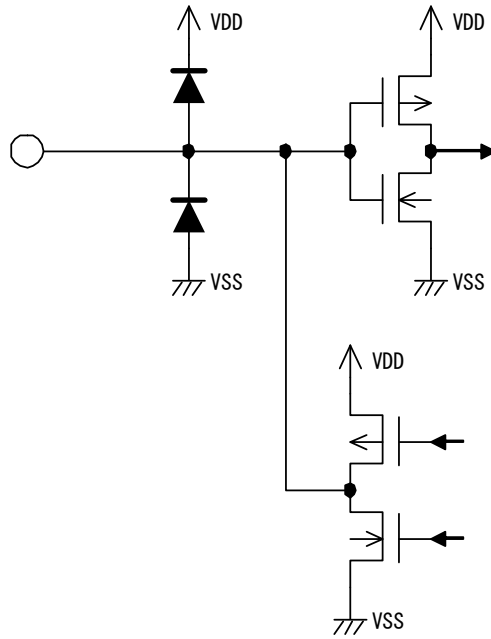

Applicable to pins FR, DIO1, and DIO2.

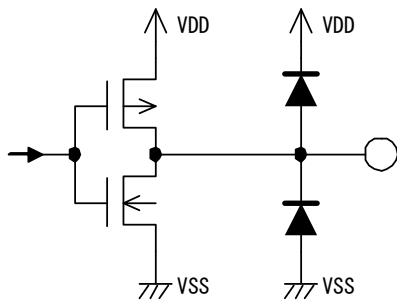

Applicable to pins  $\overline{\text{DOC}}$ .

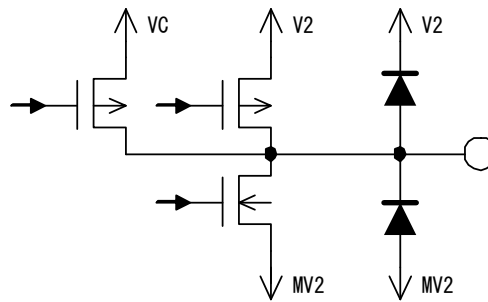

Applicable to pins O1~240.

### 3. Block Diagram

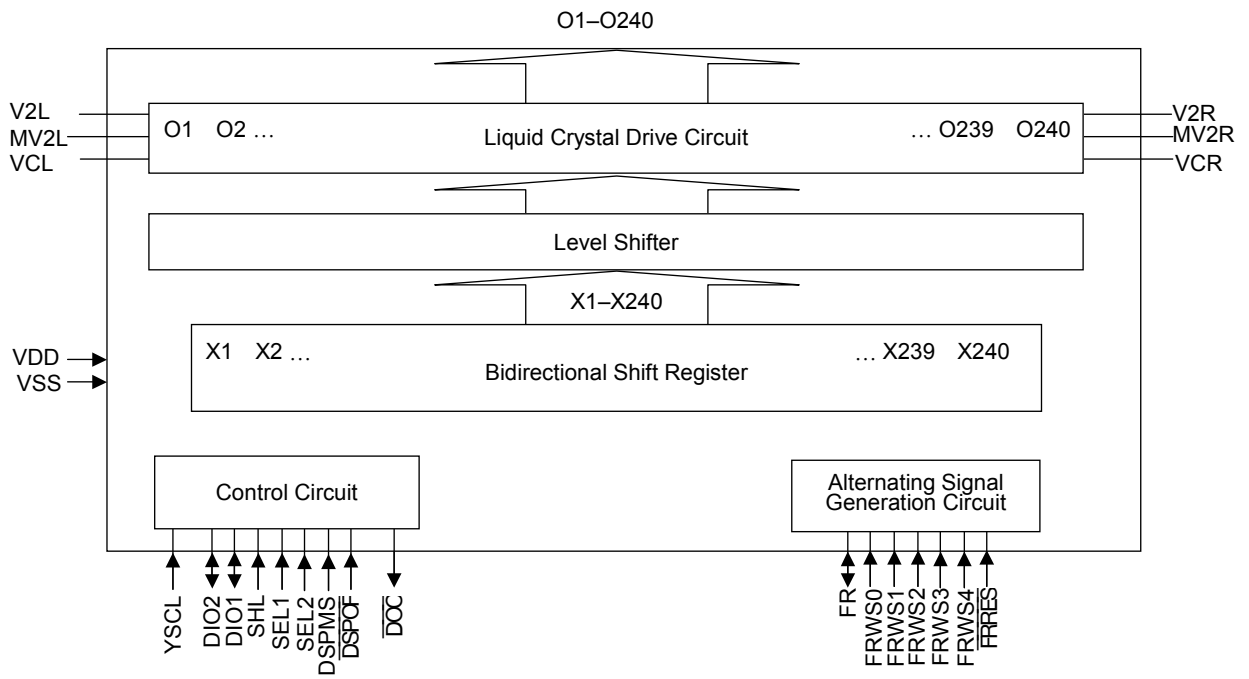

## 4. Functional Description

### 4.1 Internal Blocks

#### 4.1.1 Liquid Crystal Drive Circuit

The liquid crystal drive circuit outputs three levels for liquid crystal drive. One of the three liquid crystal drive levels (V2, MV2, VC) is selected and output according to the combination of data stored in the shift register circuit and FR, as shown below.

| FR  | Display data | $\overline{DSPOF}$ | Output level |
|-----|--------------|--------------------|--------------|
| *   | *            | "L"                | VC           |
| "L" | "L"          | "H"                | VC           |
| "L" | "H"          | "H"                | V2           |
| "H" | "L"          | "H"                | VC           |
| "H" | "H"          | "H"                | MV2          |

\*: Don't care

The number of output pins is set by the SEL1 and SEL2 settings, as shown below.

| SEL1 | SEL2 | Number of output pins                        |
|------|------|--|
| "H"  | "H"  | 240 outputs (O1, O2, O3, ..., O239, O240)    |
| "H"  | "L"  | 200 outputs (O21, O22, O23, ..., O219, O220) |
| "L"  | "H"  | 160 outputs (O41, O42, O43, ..., O199, O200) |
| "L"  | "L"  | 120 outputs (O61, O62, O63, ..., O179, O180) |

Pins that are made disabled by the SEL1 and SEL2 pins will output the nonselective level signal (VC) synchronized with the FR signal.

#### 4.1.2 Level Shifter

The level shifter converts 5 V signals to high-voltage signals used for liquid crystal drive by multiplying the voltage.

#### 4.1.3 Bidirectional Shift Register

The device is equipped with a 240-bit bidirectional shift register, where the first line signals that are input from the DIO1 and DIO2 pins are shifted sequentially. The shift direction is determined by the SHL pin setting.

**Relationship between SHL, DIO1, and DIO2**

| SHL | DIO1          | DIO2          |
|-----|---------------|---------------|
| "H" | Serial output | Serial input  |
| "L" | Serial input  | Serial output |

Relationship between SEL1/SEL2 and Shift Direction

| SHL | SEL1 | SEL2 | Shift direction        |
|-----|------|------|------------------------|
| "H" | "H"  | "H"  | DIO2→X1→...→X240→DIO1  |
|     | "H"  | "L"  | DIO2→X21→...→X220→DIO1 |
|     | "L"  | "H"  | DIO2→X41→...→X200→DIO1 |
|     | "L"  | "L"  | DIO2→X61→...→X180→DIO1 |
| "L" | "H"  | "H"  | DIO1→X240→...→X1→DIO2  |
|     | "H"  | "L"  | DIO1→X220→...→X21→DIO2 |
|     | "L"  | "H"  | DIO1→X200→...→X41→DIO2 |
|     | "L"  | "L"  | DIO1→X180→...→X61→DIO2 |

#### 4.1.4 Alternating Signal Generation Circuit

The alternating signal generation circuit generates the alternation signal for liquid crystal display (FR signal). Alternating is enabled by setting each pin from FRWS0 to FRWS4 to VDD or VSS. When inputting alternating signals externally, alternating is enabled by setting all the pins from FRWS0 to FRWS4 to VSS.

| Number of lines | FRWS4 | FRWS3 | FRWS2 | FRWS1 | FRWS0 | Line alternating waveform | FR pin status | Remarks |
|-----------------|-------|-------|-------|-------|-------|---------------------------|---------------|---------|
| 0               | 0     | 0     | 0     | 0     | 0     | —                         | Input         |         |
| 1               | 0     | 0     | 0     | 0     | 1     | 1 line alternated         | Output        | (*1)    |
| 2               | 0     | 0     | 0     | 1     | 0     | 2 lines alternated        |               |         |
| 3               | 0     | 0     | 0     | 1     | 1     | 3 lines alternated        |               |         |
| λ               | λ     | λ     | λ     | λ     | λ     | λ                         |               |         |
| 31              | 1     | 1     | 1     | 1     | 1     | 31 lines alternated       |               |         |

\*1: This setting is prohibited.

#### 4.1.5 Control Circuit

Based on the DSPMS pin status, the control circuit processes the  $\overline{\text{DSPOF}}$  signal internally and outputs the generated signal to the  $\overline{\text{DOC}}$  signal.

| DSPMS | $\overline{\text{DSPOF}}$ signal and internal processing  |
|-------|---|
| "H"   | The liquid crystal output is set to the VC level during the "L" period of the $\overline{\text{DSPOF}}$ signal.   |
| "L"   | Holds the liquid crystal output at the VC level until 16 frames of data are input to DIO1 and DIO2 after a level change from "L" → "H" on the $\overline{\text{DSPOF}}$ signal. |
| DSPMS | $\overline{\text{DOC}}$   |
| "H"   | Outputs "L" while the $\overline{\text{DSPOF}}$ signal is at "L".   |
|       | Outputs "H" while the $\overline{\text{DSPOF}}$ signal is at "H".   |
| "L"   | Even if the $\overline{\text{DSPOF}}$ signal level changes from "L" → "H", a "L" level is output until 16 frames of data are input to DIO1 and DIO2.                            |

## 4.2 Timing Diagram

### 4.2.1 Timing of Connection with the Segment Driver

Input signal FR is latched at the rise of input signal YSCL and is propagated to the liquid crystal drive circuit at the next fall of YSCL. The DATA signal that is input from the DIO1 and DIO2 pins is latched at the fall of the YSCL signal and propagated to the liquid crystal drive circuit. The liquid crystal drive signal level (V2, MC, MV2) is determined by the operation between the FR signal propagated to the liquid crystal drive circuit and the DATA signal.

When using output of the FR signal through the FR signal generation circuit, connect the FR signal to the FR pin of the ML9461B directly. The FR signal inside of the LSI is processed by delaying it by two YSCL signals for the FR signal output from the common driver.

Timing Diagram when the FR pin is configured as input

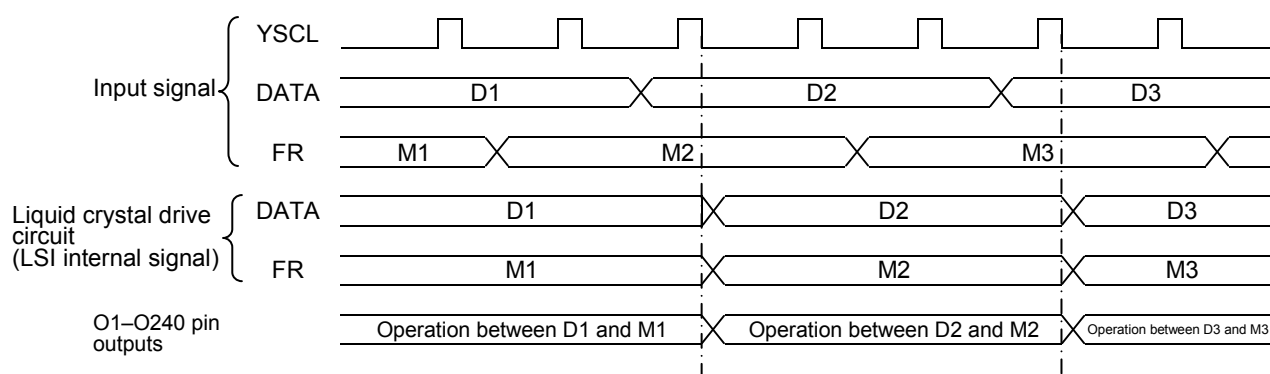

Timing Diagram when the FR pin is configured as output

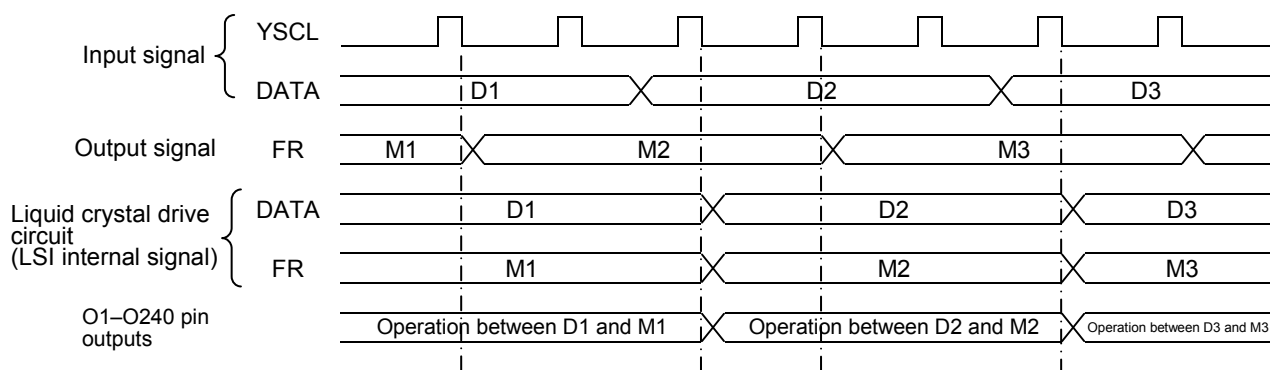

4.2.2 Driver Output Waveform

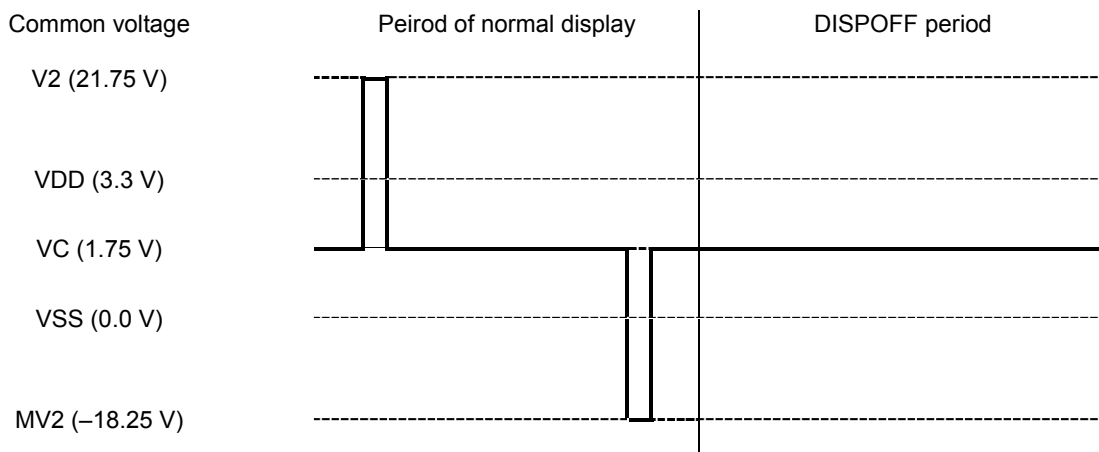

4.2.3  $\overline{\text{DOC}}$  Signal Waveforms

When DSPMS = "H"

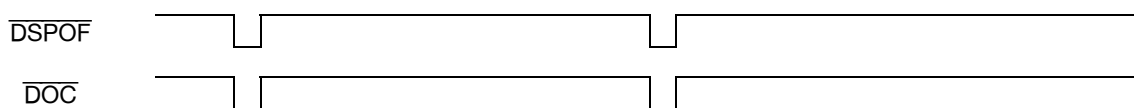

When DSPMS = "L"

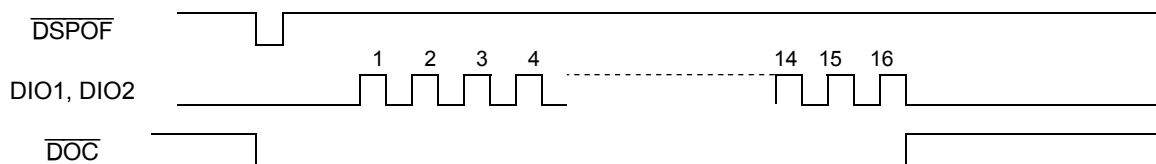

4.2.4 Timing Waveforms of AC Characteristics

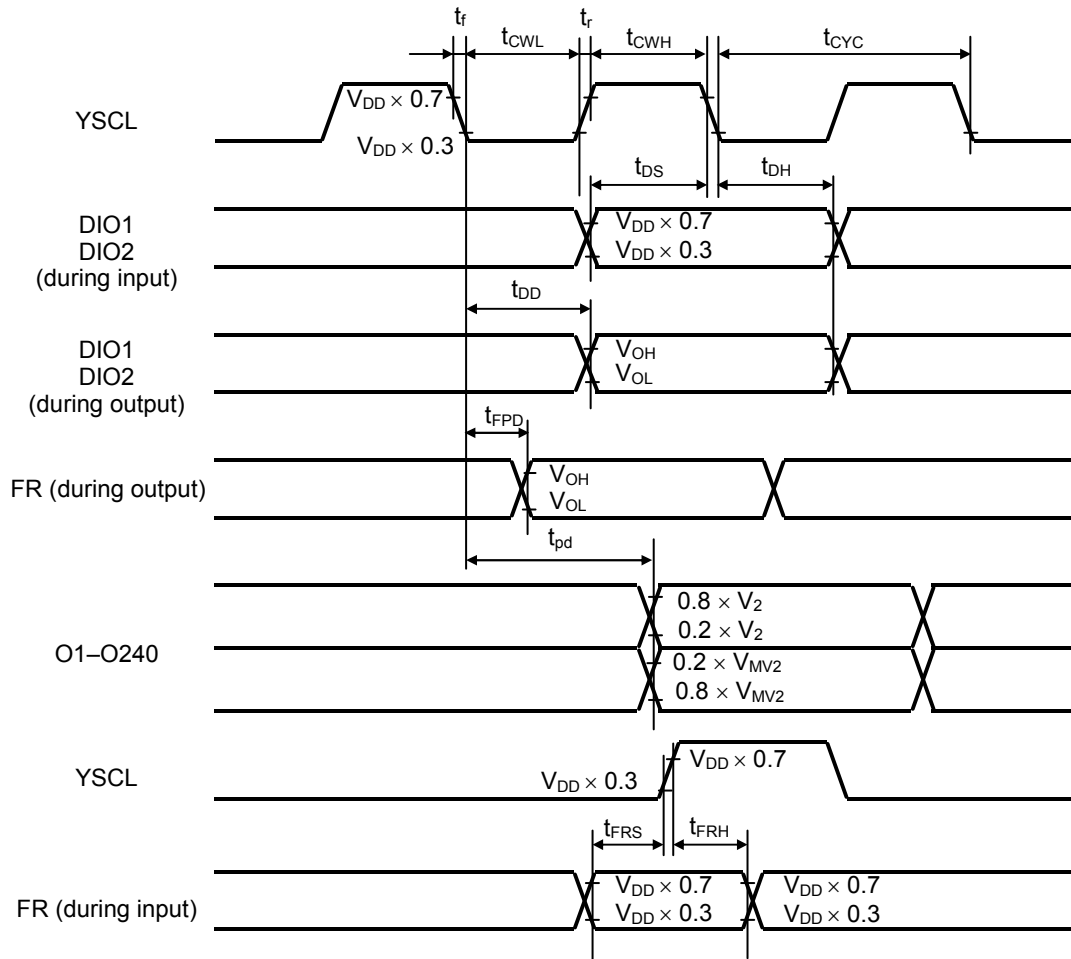

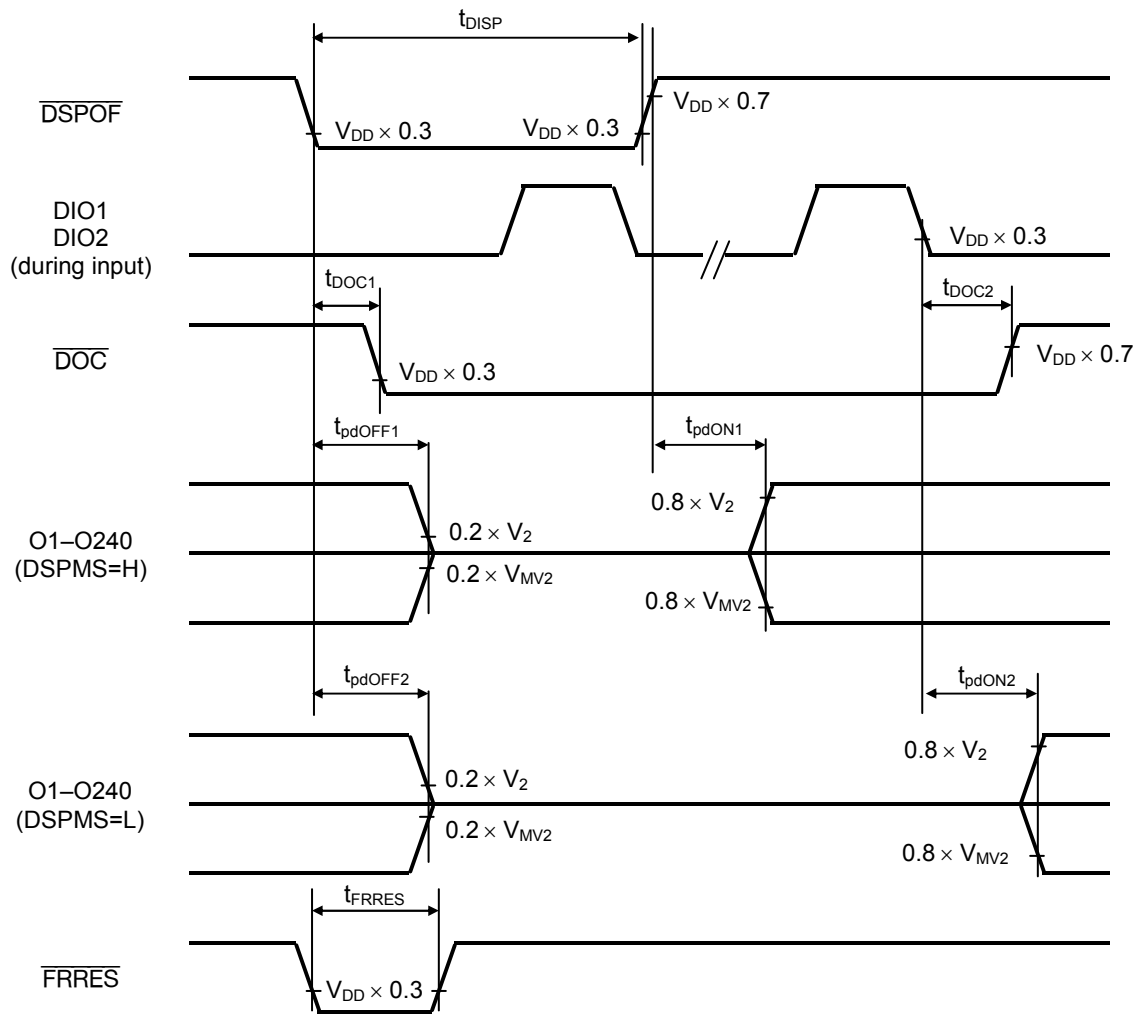

4.2.5 Alternating Waveforms

SEL1="H", SEL2="H"(240Output), SHL="H", FR Signal Internal generation, 3 lines inverted

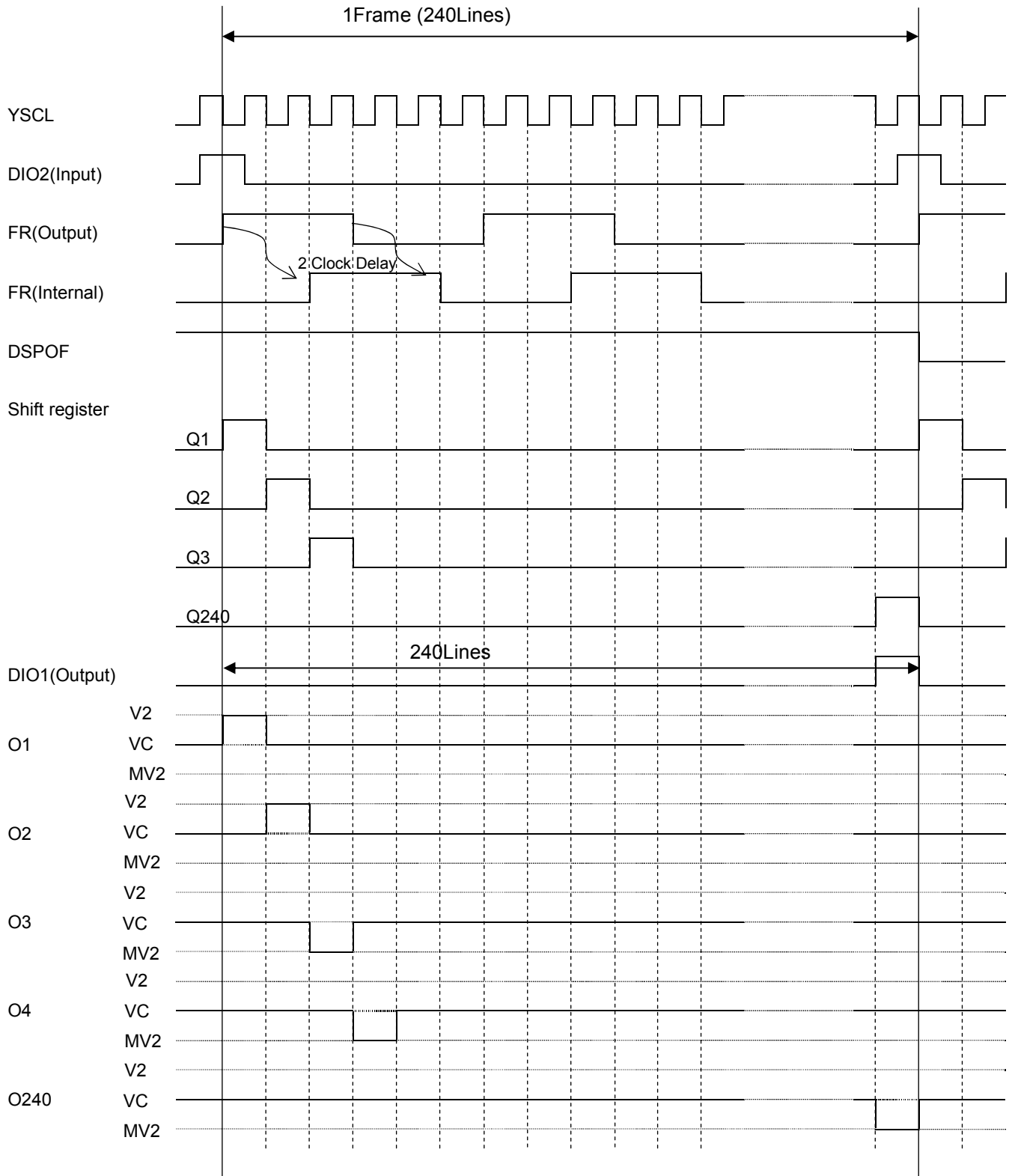

SEL1="H", SEL2="H"(240Output), SHL="H", FR Signal Internal generation, 3 lines inverted

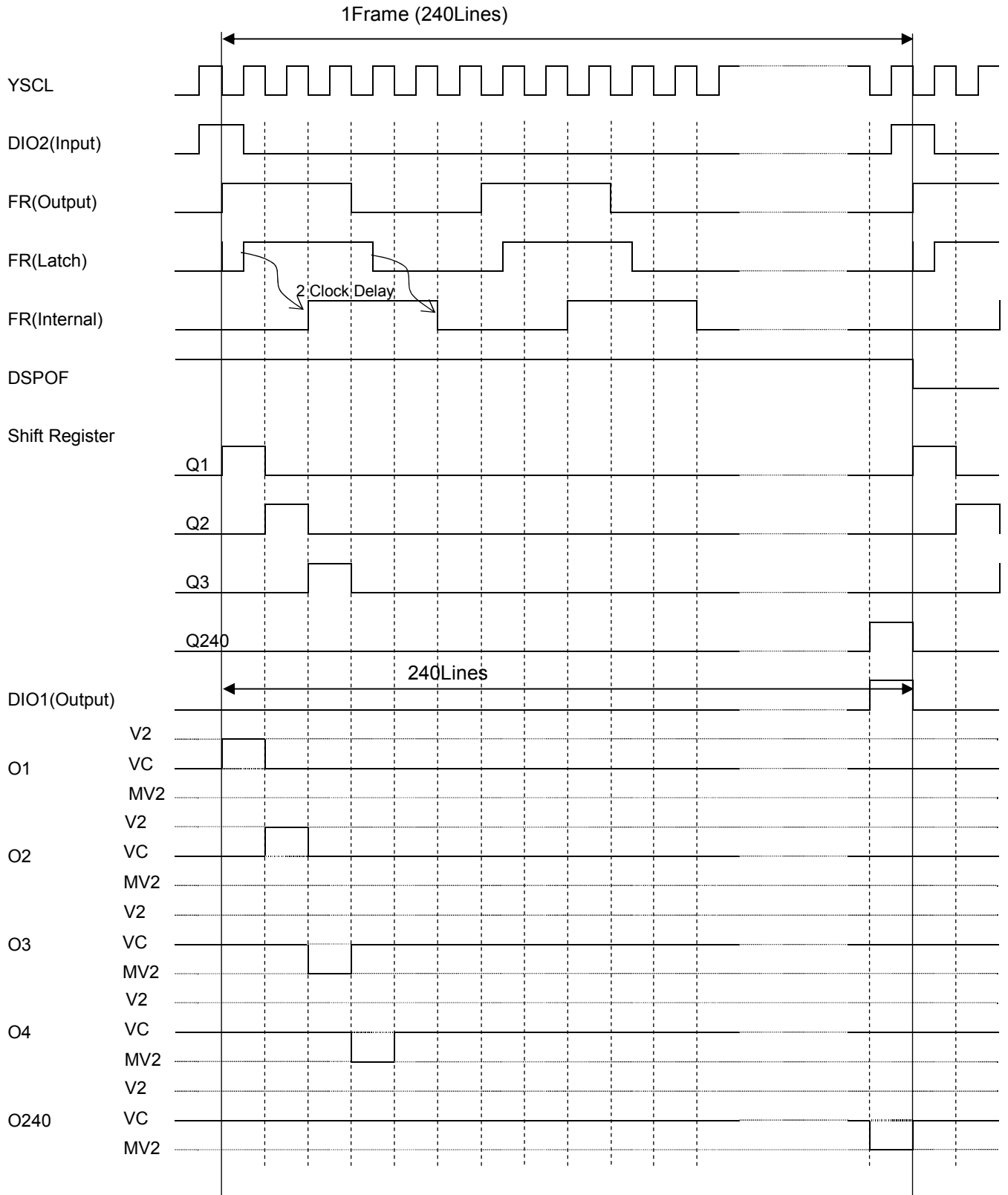

## 5. Power Supply System

### 5.1 Power Supply Group

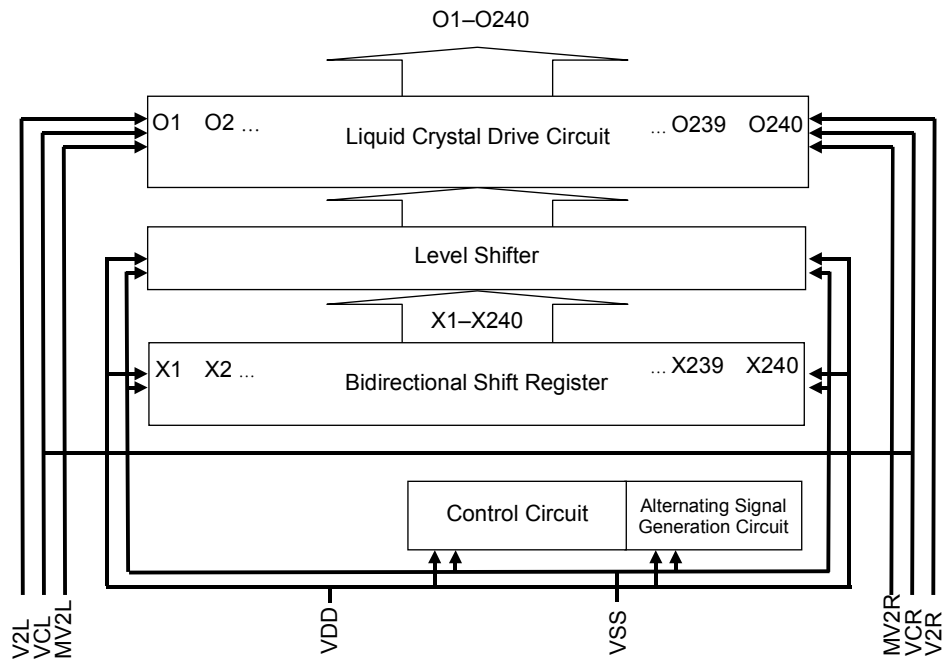

This LSI does completely separate Liquid crystal drive voltage and Operating voltage on its circuit architecture. Please do an anti-noise measure on a panel so that noise Liquid crystal drive voltage does not round it in Operating voltage.

## 5.2 Power-On/Shutdown Sequence

### 5.2.1 Power-On Sequence

1. Apply power to (1)VSS–VDD, (2)VSS–V2, (3)VC, and (4)MV2 in this order. Then, input the VSS potential to the  $\overline{\text{DSPOF}}$  pin.
2. The O1–O240 pins forcibly outputs the VC level by the DISPOFF function.
3. Even if an input signal is disturbed immediately after VDD is applied, priority is given to the DISPOFF function.
4. Input the predetermined signal(s) to initialize the registers in the driver. In this case, take at least one frame for the initialization period.
5. Input the VDD voltage to the  $\overline{\text{DSPOF}}$  pin to release the DISPOFF function. At this point, the levels of the MV2, V2, and VC pin must have reached their respective predetermined potentials.

### 5.2.2 Shutdown Sequence

1. The  $\overline{\text{DSPOF}}$  pin must remain set to the VSS potential.
2. Shut down the power supplies for liquid crystal in the order of (1)VSS–V2, (2)VC, and (3)MV2.
3. Reduce the voltage of VDD and the levels of the input signals to the VSS potential. At this point, the V2 and VC pin must completely drop to 3 V or lower.

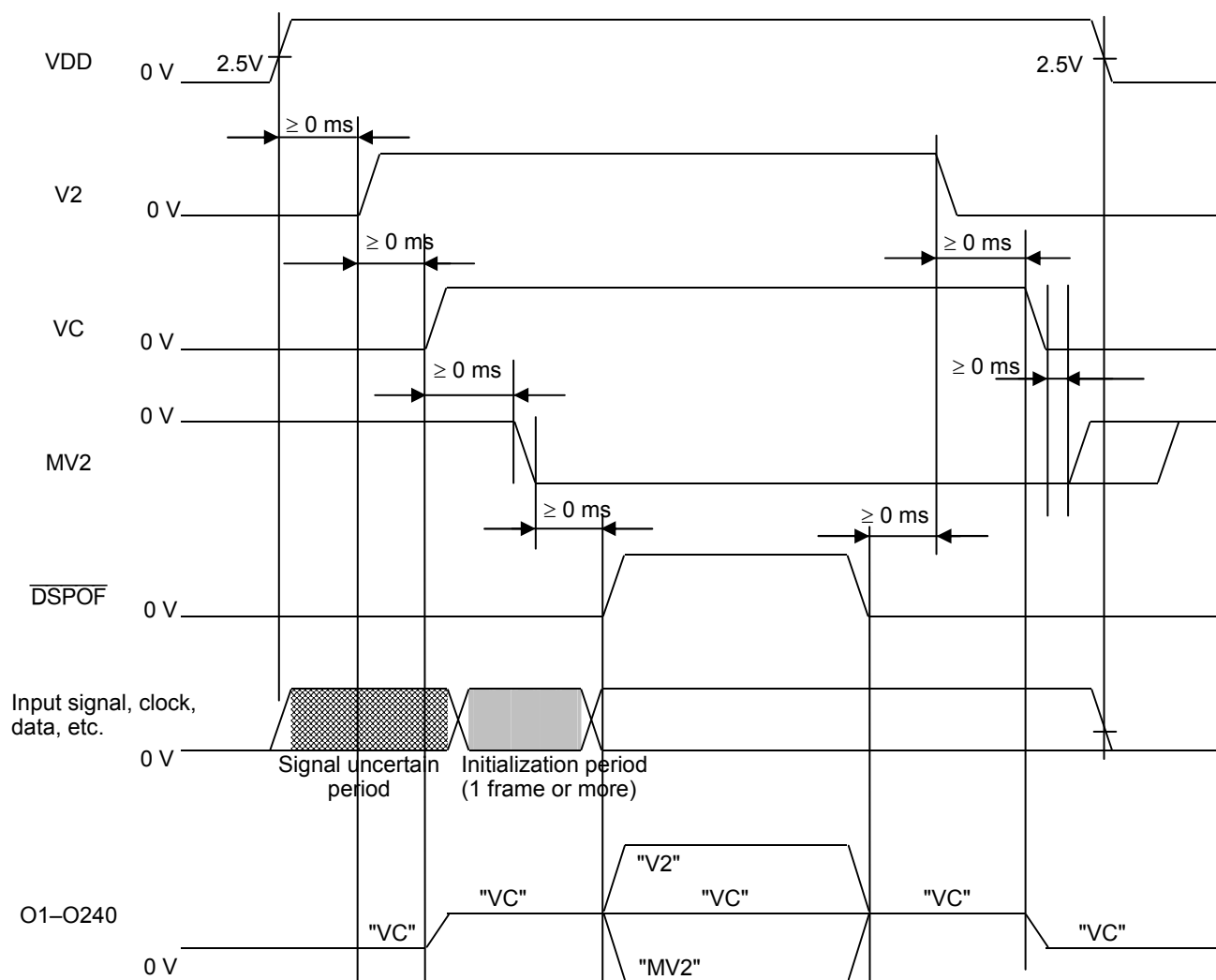

## 6. Electrical Specifications

### 6.1 Absolute Maximum Ratings

 $V_{SS} = 0V$ 

| Parameter                                   | Symbol                       | Condition                              | Rating                                 | Unit          | Applicable pins   |                      |
|---|------------------------------|--|--|---------------|---|----------------------|
| Power supply voltage                        | Logic circuit                | $V_{DD}$                               | $T_j = -30^{\circ}C$ to $+75^{\circ}C$ | -0.3 to +7.0  | V   | VDD                  |
|   | liquid crystal drive circuit | $V_2$                                  | $T_j = -30^{\circ}C$ to $+75^{\circ}C$ | -0.3 to +25.0 | V   | V2L, V2R             |
|   |                              | $V_{MV2}$                              | $T_j = -30^{\circ}C$ to $+75^{\circ}C$ | -22.5 to +0.3 | V   | MV2L, MV2R           |
|   |                              | $V_M - V_{MV2}$                        | $T_j = -30^{\circ}C$ to $+75^{\circ}C$ | -0.3 to +45.0 | V   | V2L, V2R, MV2L, MV2R |
| Input voltage (1)                           | $V_{t1}$                     | $T_j = -30^{\circ}C$ to $+75^{\circ}C$ | -0.3 to $V_{DD} + 0.3$                 | V             | DIO1, $\overline{DSPOF}$ , SHL, FR, FRWS0, FRWS1, FRWS2, FRWS3, FRWS4, FRRES, SEL1, SEL2, YSCL, DSPMS, DIO2 |                      |
| Input voltage (2)                           | $V_2$                        | $T_j = -30^{\circ}C$ to $+75^{\circ}C$ | -0.3 to +25.0                          | V             | V2L, V2R  |                      |
| Input voltage (3)                           | $V_{MV2}$                    | $T_j = -30^{\circ}C$ to $+75^{\circ}C$ | -22.5 to +0.3                          | V             | MV2L, MV2R  |                      |
| Input voltage (4)                           | $V_C$                        | $T_j = -30^{\circ}C$ to $+75^{\circ}C$ | -0.3 to +5.0                           | V             | VCL, VCR  |                      |
| Output current/output short-circuit current | $I_O$                        | $T_j = -30^{\circ}C$ to $+75^{\circ}C$ | 10                                     | mA            | FR, DIO1, DIO2, $\overline{DOC}$ , O1–O240  |                      |
| Junction temperature                        | $T_j$                        | —                                      | -55 to +110                            | $^{\circ}C$   | —   |                      |
| Storage temperature range                   | $T_{stg}$                    | —                                      | -55 to +110                            | $^{\circ}C$   | —   |                      |

## 6.2 Recommended Operating Conditions (Guaranteed Operating Range)

$$V_{SS} = 0V, V_2 - V_{MV2} = 15 \text{ to } 43V, T_j = -30 \text{ to } +75^\circ\text{C}$$

| Parameter                              | Symbol                       | Condition   | Range               |      |                     | Unit | Applicable pins  |          |
|--|------------------------------|-------------|---------------------|------|---------------------|------|--|----------|
|  |                              |             | Min.                | Typ. | Max.                |      |  |          |
| Power supply voltage                   | Logic circuit                | $V_{DD}$    | —                   | 2.5  | —                   | 5.5  | V  | VDD      |
|  | liquid crystal drive circuit | $V_2$       | —                   | 8.8  | —                   | 24   | V  | V2L, V2R |
| $V_{MV2}$                              |                              | —           | -21.5               | —    | -4                  | V    | MV2L, MV2R   |          |
| “H” Input voltage                      | $V_{IH}$                     | —           | $0.7 \times V_{DD}$ | —    | $V_{DD}$            | V    | DIO1, $\overline{DSPOF}$ , SHL, FR, DSPMS, FRWS0, FRWS1, FRWS2, FRWS3, FRWS4, $\overline{FRRES}$ , YSCL, SEL1, SEL2, $\overline{DOC}$ , DIO2 |          |
| “L” Input voltage                      | $V_{IL}$                     | —           | 0                   | —    | $0.3 \times V_{DD}$ | V    |  |          |
| liquid crystal drive Input voltage (1) | $V_2$                        | —           | 8.8                 | —    | 24                  | V    | V2L, V2R   |          |
| liquid crystal drive Input voltage (2) | $V_{MV2}$                    | —           | -21.5               | —    | -4                  | V    | MV2L, MV2R   |          |
| liquid crystal drive Input voltage (3) | $V_C$                        | —           | 0                   | —    | 3.5                 | V    | VCL, VCR   |          |
| Operating frequency                    | $f_{CK}$                     | $V_{DD}=5V$ | (*1)                | —    | 4                   | MHz  | YSCL   |          |
|  |                              | $V_{DD}=3V$ | (*1)                | —    | 3                   | MHz  | YSCL   |          |
| Operating temperature (Tj)             | $T_{opr}$                    | —           | -30                 | —    | 75                  | °C   | —  |          |
| Load condition 1                       | $C_{L1}$                     | —           | —                   | —    | 30                  | pF   | DIO1, DIO2   |          |
| Load condition 2                       | $C_{L2}$                     | —           | —                   | —    | 100                 | pF   | $\overline{DOC}$ , O1-O240   |          |
| Input rise waveform                    | $t_r$                        | —           | —                   | —    | 30                  | ns   | YSCL   |          |
| Input fall waveform                    | $t_f$                        | —           | —                   | —    | 30                  | ns   | YSCL   |          |
| Clock “High” period                    | $t_{CWH}$                    | —           | 20                  | —    | —                   | ns   | YSCL   |          |
| Clock “Low” period                     | $t_{CWL}$                    | —           | 250                 | —    | —                   | ns   | YSCL   |          |
| Data setup time                        | $t_{DS}$                     | —           | 70                  | —    | —                   | ns   | DIO1, DIO2, YSCL   |          |
| Data hold time                         | $t_{DH}$                     | —           | 10                  | —    | —                   | ns   | DIO1, DIO2, YSCL   |          |
| FR setup time                          | $t_{FRS}$                    | —           | 20                  | —    | —                   | ns   | FR, YSCL   |          |
| FR hold time                           | $t_{FRH}$                    | —           | 20                  | —    | —                   | ns   | FR, YSCL   |          |

“—” indicates that no particular value is specified.

\*1: 5kHz is specified for the test condition.

### Note:

Insert bypass capacitors by referring to the Application Circuit described later so that power supplies will be stabilized. It is recommended that 0.1  $\mu\text{F}$  CA capacitors (JIS (Japanese Industrial Standards) FJ(F) equivalent) be used.

## 6.3 DC Characteristics

$$V_{DD} = 2.5 \text{ to } 5.5\text{V}, V_{SS} = 0\text{V}, V_2 - V_{MV2} = 15 \text{ to } 43\text{V}, T_j = -30 \text{ to } +75^\circ\text{C}$$

| No. | Parameter                             | Symbol    | Condition   | Min.                | Typ. | Max.                | Unit             | Applicable pins   |
|-----|---------------------------------------|-----------|---|---------------------|------|---------------------|------------------|---|
| 1   | "H" level input voltage               | $V_{IH}$  | —   | $V_{DD} \times 0.7$ | —    | $V_{DD}$            | V                | DIO1, $\overline{\text{DSPOF}}$ ,<br>SHL, FR, DSPMS,<br>FRWS0, FRWS1,<br>FRWS2, FRWS3,<br>FRWS4, $\overline{\text{FRRES}}$ ,<br>YSCL, SEL1,<br>SEL2, DIO2 |
| 2   | "L" level input voltage               | $V_{IL}$  | —   | 0                   | —    | $V_{DD} \times 0.3$ | V                |   |
| 3   | "H" level output voltage              | $V_{OH}$  | $I_{OH} = -0.4\text{mA}$  | $V_{DD} - 0.4$      | —    | —                   | V                | FR, DIO1, DIO2,<br>DOC  |
| 4   | "L" level output voltage              | $V_{OL}$  | $I_{OL} = 0.4\text{mA}$   | —                   | —    | 0.4                 | V                |   |
| 5   | Supply current (1)                    | $I_{CC1}$ | $V_{DD} = 3.3\text{V}$<br>$V_2 - V_{MV2} = 40\text{V}$<br>$f_{YSCL} = 19.2\text{kHz}$<br>$f_{FR} = 1.5\text{kHz}$<br>240-output mode<br>$T_a = 25^\circ\text{C}$<br>No load | —                   | 10   | 40                  | $\mu\text{A}$    | VDD   |
| 6   | Supply current (2)                    | $I_{CC2}$ | $V_{DD} = 5.0\text{V}$<br>$V_2 - V_{MV2} = 40\text{V}$<br>$f_{YSCL} = 19.2\text{kHz}$<br>$f_{FR} = 1.5\text{kHz}$<br>240-output mode<br>$T_a = 25^\circ\text{C}$<br>No load | —                   | 20   | 50                  | $\mu\text{A}$    | VDD   |
| 7   | Supply current (3)                    | $I_{CC3}$ | $V_{DD} = 3.3\text{V}$<br>$V_2 - V_{MV2} = 40\text{V}$<br>$f_{YSCL} = 19.2\text{kHz}$<br>$f_{FR} = 1.5\text{kHz}$<br>240-output mode<br>$T_a = 25^\circ\text{C}$<br>No load | —                   | 25   | 50                  | $\mu\text{A}$    | V2  |
| 8   | Static supply current                 | $I_{DDS}$ | $T_a = 25^\circ\text{C}$  | —                   | —    | 10                  | $\mu\text{A}$    | VDD   |
| 9   | Input leakage current 1               | $I_{IL1}$ | $V_{IN} = V_{DD} \text{ to } V_{SS}$  | -5                  | —    | 5                   | $\mu\text{A}$    | DIO1, $\overline{\text{DSPOF}}$ ,<br>SHL, FR, DSPMS,<br>FRWS0, FRWS1,<br>FRWS2, FRWS3,<br>FRWS4, $\overline{\text{FRRES}}$ ,<br>YSCL, SEL1,<br>SEL2, DIO2 |
| 10  | Input leakage current 2               | $I_{IL2}$ | —   | -25                 | —    | 25                  | $\mu\text{A}$    | VCL, VCR  |
| 11  | ON resistance between $V_i$ and $O_j$ | $R_{ON}$  | $\Delta V_{ON} = 0.5\text{V}$<br>$V_2 = 21.75\text{V}$<br>$V_{MV2} = -18.25\text{V}$<br>$V_C = 1.75\text{V}$  | —                   | 0.7  | 2.0                 | $\text{k}\Omega$ | O1–O240   |
|     |                                       |           | $\Delta V_{ON} = 0.5\text{V}$<br>$V_2 = 11.75\text{V}$<br>$V_{MV2} = -8.25\text{V}$<br>$V_C = 1.75\text{V}$   | —                   | 1.2  | 3.3                 | $\text{k}\Omega$ | O1–O240   |

Values in the Typ. column are for reference only.

“—” indicates that no particular value is specified.

## 6.4 AC Characteristics

### 6.4.1 AC Characteristics 1

$V_{DD} = 2.5$  to  $4.5V$ ,  $V_{SS} = 0V$ ,  $V_2 = 21.5V$ ,  $V_C = 0V$ ,  $V_{MV2} = -21.5V$ ,  $T_j = -30$  to  $+75^\circ C$

| No. | Parameter   | Symbol      | Condition      | Min. | Typ. | Max. | Unit | Applicable pins                       |
|-----|---|-------------|----------------|------|------|------|------|---------------------------------------|
| 1   | Clock cycle time                                      | $t_{CYC}$   | —              | 330  | —    | —    | ns   | YSCL                                  |
| 2   | YSCL “H” level width                                  | $t_{CWH}$   | —              | 20   | —    | —    | ns   | YSCL                                  |
| 3   | YSCL “L” level width                                  | $t_{CWL}$   | —              | 250  | —    | —    | ns   | YSCL                                  |
| 4   | YSCL rise time  | $t_r$       | —              | —    | —    | 30   | ns   | YSCL                                  |
| 5   | YSCL fall time  | $t_f$       | —              | —    | —    | 30   | ns   | YSCL                                  |
| 6   | Data setup time                                       | $t_{DS}$    | —              | 70   | —    | —    | ns   | DIO1, DIO2, YSCL                      |
| 7   | Data hold time  | $t_{DH}$    | —              | 10   | —    | —    | ns   | DIO1, DIO2, YSCL                      |
| 8   | Data output delay time                                | $t_{DD}$    | (*1)           | —    | —    | 200  | ns   | DIO1, DIO2, YSCL                      |
| 9   | FR output delay time                                  | $t_{FRD}$   | (*1)           | —    | —    | 140  | ns   | FR, YSCL                              |
| 10  | FR setup time   | $t_{FRS}$   | —              | 20   | —    | —    | ns   | FR, YSCL                              |
| 11  | FR hold time  | $t_{FRH}$   | —              | 20   | —    | —    | ns   | FR, YSCL                              |
| 12  | $\overline{DOC}$ output delay time 1                  | $t_{DOC1}$  | DSPMS = H (*2) | —    | —    | 200  | ns   | $\overline{DSPOF}$ , $\overline{DOC}$ |
|     |   |             | DSPMS = L (*2) | —    | —    | 1500 | ns   | $\overline{DSPOF}$ , $\overline{DOC}$ |
| 13  | $\overline{DOC}$ output delay time 2                  | $t_{DOC2}$  | (*2)           | —    | —    | 300  | ns   | DIO1, DIO2, $\overline{DOC}$          |
| 14  | Common output delay time from $\overline{DSPOF}$ fall | $t_{pdFF1}$ | DSPMS = H (*2) | —    | —    | 1200 | ns   | $\overline{DSPOF}$ , O1 to O240       |
|     |   |             | DSPMS = L (*2) | —    | —    | 2500 | ns   | $\overline{DSPOF}$ , O1 to O240       |
| 15  | Common output delay time from $\overline{DSPOF}$ rise | $t_{pdON1}$ | DSPMS = H (*2) | —    | —    | 1200 | ns   | $\overline{DSPOF}$ , O1 to O240       |
| 16  | Common output delay time from DIO fall                | $t_{pdON2}$ | DSPMS = L (*2) | —    | —    | 1200 | ns   | DIO1, DIO2, O1 to O240                |
| 17  | $\overline{DSPOF}$ “L” level width (*3)               | $t_{DISP}$  | DSPMS = L      | 100  | —    | —    | ns   | $\overline{DSPOF}$                    |
| 18  | $\overline{FRRES}$ “L” level width (*3)               | $t_{FRRES}$ | —              | 100  | —    | —    | ns   | $\overline{FRRES}$                    |

Values in the Typ. column are for reference only.

“—” indicates that no particular value is specified.

$$V_{DD} = 4.5 \text{ to } 5.5\text{V}, V_{SS} = 0\text{V}, V_2 = 21.5\text{V}, V_C = 0\text{V}, V_{MV2} = -21.5\text{V}, T_j = -30 \text{ to } +75^\circ\text{C}$$

| No. | Parameter  | Symbol       | Condition      | Min. | Typ. | Max. | Unit | Applicable pins                                     |
|-----|--|--------------|----------------|------|------|------|------|---|
| 1   | Clock cycle time   | $t_{CYC}$    | —              | 245  | —    | —    | ns   | YSCL  |
| 2   | YSCL "H" level width   | $t_{CWH}$    | —              | 15   | —    | —    | ns   | YSCL  |
| 3   | YSCL "L" level width   | $t_{CWL}$    | —              | 170  | —    | —    | ns   | YSCL  |
| 4   | YSCL rise time   | $t_r$        | —              | —    | —    | 30   | ns   | YSCL  |
| 5   | YSCL fall time   | $t_f$        | —              | —    | —    | 30   | ns   | YSCL  |
| 6   | Data setup time  | $t_{DS}$     | —              | 50   | —    | —    | ns   | DIO1, DIO2, YSCL                                    |
| 7   | Data hold time   | $t_{DH}$     | —              | 10   | —    | —    | ns   | DIO1, DIO2, YSCL                                    |
| 8   | Data output delay time                                       | $t_{DD}$     | (*1)           | —    | —    | 150  | ns   | DIO1, DIO2, YSCL                                    |
| 9   | FR output delay time   | $t_{FRD}$    | (*1)           | —    | —    | 100  | ns   | FR, YSCL  |
| 10  | FR setup time  | $t_{FRS}$    | —              | 15   | —    | —    | ns   | FR, YSCL  |
| 11  | FR hold time   | $t_{FRH}$    | —              | 15   | —    | —    | ns   | FR, YSCL  |
| 12  | $\overline{\text{DOC}}$ output delay time 1                  | $t_{DOC1}$   | DSPMS = H (*2) | —    | —    | 140  | ns   | $\overline{\text{DSPOF}}$ , $\overline{\text{DOC}}$ |
|     |  |              | DSPMS = L (*2) | —    | —    | 1000 | ns   | $\overline{\text{DSPOF}}$ , $\overline{\text{DOC}}$ |
| 13  | $\overline{\text{DOC}}$ output delay time 2                  | $t_{DOC2}$   | (*2)           | —    | —    | 200  | ns   | DIO1, DIO2, $\overline{\text{DOC}}$                 |
| 14  | Common output delay time from $\overline{\text{DSPOF}}$ fall | $t_{pdOFF1}$ | DSPMS = H (*2) | —    | —    | 700  | ns   | $\overline{\text{DSPOF}}$ , O1 to O240              |
|     |  |              | DSPMS = L (*2) | —    | —    | 2000 | ns   | $\overline{\text{DSPOF}}$ , O1 to O240              |
| 15  | Common output delay time from $\overline{\text{DSPOF}}$ rise | $t_{pdON1}$  | DSPMS = H (*2) | —    | —    | 700  | ns   | $\overline{\text{DSPOF}}$ , O1 to O240              |
| 16  | Common output delay time from DIO fall                       | $t_{pdON2}$  | DSPMS = L (*2) | —    | —    | 700  | ns   | DIO1, DIO2, O1 to O240                              |
| 17  | $\overline{\text{DSPOF}}$ "L" level width(*3)                | $t_{DISP}$   | DSPMS = L      | 100  | —    | —    | ns   | $\overline{\text{DSPOF}}$                           |
| 18  | $\overline{\text{FRRES}}$ "L" level width(*3)                | $t_{FRRES}$  | —              | 100  | —    | —    | ns   | $\overline{\text{FRRES}}$                           |

Values in the Typ. column are for reference only.

“—” indicates that no particular value is specified.

## 6.4.2 AC Characteristics 2

 $V_{DD} = 2.5 \text{ to } 4.5\text{V}, V_{SS} = 0\text{V}, V_2 = 21.5\text{V}, V_C = 0\text{V}, V_{MV2} = -21.5\text{V}, T_j = -30 \text{ to } +75^\circ\text{C}$ 

| No. | Parameter         | Symbol   | Condition | Min. | Typ. | Max. | Unit          | Applicable pins |
|-----|-------------------|----------|-----------|------|------|------|---------------|-----------------|
| 1   | Output delay time | $t_{pd}$ | (*2)      | —    | —    | 1.2  | $\mu\text{s}$ | O1–O240, FR     |

“—” indicates that no particular value is specified.

## 6.4.3 AC Characteristics 3

 $V_{DD} = 4.5 \text{ to } 5.5\text{V}, V_{SS} = 0\text{V}, V_2 = 21.5\text{V}, V_C = 0\text{V}, V_{MV2} = -21.5\text{V}, T_j = -30 \text{ to } +75^\circ\text{C}$ 

| No. | Parameter         | Symbol   | Condition | Min. | Typ. | Max. | Unit          | Applicable pins |
|-----|-------------------|----------|-----------|------|------|------|---------------|-----------------|
| 1   | Output delay time | $t_{pd}$ | (*2)      | —    | —    | 0.7  | $\mu\text{s}$ | O1–O240, FR     |

“—” indicates that no particular value is specified.

\*1: Load condition

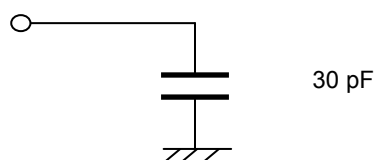

\*2: Load condition

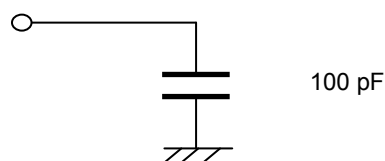

\*3: If any signal whose pulse width is shorter than this value, the device may not operate normally.

## 7. PAD CONFIGURATION

### 7.1 Pad Coordinates (Au Bump Chip: ML9460CVWA)

| No. | Pad name | x-coordinate<br>[μm] | y-coordinate<br>[μm] | No. | Pad name | x-coordinate<br>[μm] | y-coordinate<br>[μm] | No. | Pad name | x-coordinate<br>[μm] | y-coordinate<br>[μm] | No. | Pad name | x-coordinate<br>[μm] | y-coordinate<br>[μm] |
|-----|----------|----------------------|----------------------|-----|----------|----------------------|----------------------|-----|----------|----------------------|----------------------|-----|----------|----------------------|----------------------|
| 1   | DUMMY    | -5936                | -604.2               | 81  | DUMMY    | 3406.8               | -604.2               | 161 | O186     | 3275                 | 606.3                | 241 | O106     | -725                 | 606.3                |
| 2   | DUMMY    | -5870                | -604.2               | 82  | DUMMY    | 3472.8               | -604.2               | 162 | O185     | 3225                 | 606.3                | 242 | O105     | -775                 | 606.3                |
| 3   | V2L      | -5804                | -604.2               | 83  | DUMMY    | 3538.8               | -604.2               | 163 | O184     | 3175                 | 606.3                | 243 | O104     | -825                 | 606.3                |
| 4   | V2L      | -5738                | -604.2               | 84  | YSCL     | 3779                 | -604.2               | 164 | O183     | 3125                 | 606.3                | 244 | O103     | -875                 | 606.3                |
| 5   | V2L      | -5672                | -604.2               | 85  | YSCL     | 3845                 | -604.2               | 165 | O182     | 3075                 | 606.3                | 245 | O102     | -925                 | 606.3                |
| 6   | VCL      | -5539.4              | -604.2               | 86  | DSPMS    | 4141.6               | -604.2               | 166 | O181     | 3025                 | 606.3                | 246 | O101     | -975                 | 606.3                |
| 7   | VCL      | -5473.4              | -604.2               | 87  | DSPMS    | 4207.6               | -604.2               | 167 | O180     | 2975                 | 606.3                | 247 | O100     | -1025                | 606.3                |
| 8   | VCL      | -5407.4              | -604.2               | 88  | DUMMY    | 4447.8               | -604.2               | 168 | O179     | 2925                 | 606.3                | 248 | O99      | -1075                | 606.3                |
| 9   | MV2L     | -5320.1              | -604.2               | 89  | DUMMY    | 4513.8               | -604.2               | 169 | O178     | 2875                 | 606.3                | 249 | O98      | -1125                | 606.3                |
| 10  | MV2L     | -5254.1              | -604.2               | 90  | DIO1     | 4871                 | -604.2               | 170 | O177     | 2825                 | 606.3                | 250 | O97      | -1175                | 606.3                |
| 11  | MV2L     | -5188.1              | -604.2               | 91  | DIO1     | 4937                 | -604.2               | 171 | O176     | 2775                 | 606.3                | 251 | O96      | -1225                | 606.3                |
| 12  | DIO2     | -5017.1              | -604.2               | 92  | DUMMY    | 5108                 | -604.2               | 172 | O175     | 2725                 | 606.3                | 252 | O95      | -1275                | 606.3                |
| 13  | DIO2     | -4951.1              | -604.2               | 93  | DUMMY    | 5174                 | -604.2               | 173 | O174     | 2675                 | 606.3                | 253 | O94      | -1325                | 606.3                |
| 14  | FR       | -4543.2              | -604.2               | 94  | MV2R     | 5240                 | -604.2               | 174 | O173     | 2625                 | 606.3                | 254 | O93      | -1375                | 606.3                |
| 15  | FR       | -4477.2              | -604.2               | 95  | MV2R     | 5306                 | -604.2               | 175 | O172     | 2575                 | 606.3                | 255 | O92      | -1425                | 606.3                |
| 16  | DUMMY    | -4306.2              | -604.2               | 96  | MV2R     | 5372                 | -604.2               | 176 | O171     | 2525                 | 606.3                | 256 | O91      | -1475                | 606.3                |
| 17  | DUMMY    | -4240.2              | -604.2               | 97  | VCR      | 5459.3               | -604.2               | 177 | O170     | 2475                 | 606.3                | 257 | O90      | -1525                | 606.3                |
| 18  | DUMMY    | -4174.2              | -604.2               | 98  | VCR      | 5525.3               | -604.2               | 178 | O169     | 2425                 | 606.3                | 258 | O89      | -1575                | 606.3                |
| 19  | DUMMY    | -4108.2              | -604.2               | 99  | VCR      | 5591.3               | -604.2               | 179 | O168     | 2375                 | 606.3                | 259 | O88      | -1625                | 606.3                |
| 20  | DUMMY    | -4042.2              | -604.2               | 100 | V2R      | 5723.9               | -604.2               | 180 | O167     | 2325                 | 606.3                | 260 | O87      | -1675                | 606.3                |
| 21  | DUMMY    | -3976.2              | -604.2               | 101 | V2R      | 5789.9               | -604.2               | 181 | O166     | 2275                 | 606.3                | 261 | O86      | -1725                | 606.3                |
| 22  | FRRES    | -3784.4              | -604.2               | 102 | V2R      | 5855.9               | -604.2               | 182 | O165     | 2225                 | 606.3                | 262 | O85      | -1775                | 606.3                |
| 23  | FRRES    | -3718.4              | -604.2               | 103 | DUMMY    | 5921.9               | -604.2               | 183 | O164     | 2175                 | 606.3                | 263 | O84      | -1825                | 606.3                |
| 24  | FRWS4    | -3310.5              | -604.2               | 104 | DUMMY    | 5987.9               | -604.2               | 184 | O163     | 2125                 | 606.3                | 264 | O83      | -1875                | 606.3                |
| 25  | FRWS4    | -3244.5              | -604.2               | 105 | DUMMY    | 6075.1               | 606.3                | 185 | O162     | 2075                 | 606.3                | 265 | O82      | -1925                | 606.3                |
| 26  | DUMMY    | -3052.7              | -604.2               | 106 | DUMMY    | 6025.1               | 606.3                | 186 | O161     | 2025                 | 606.3                | 266 | O81      | -1975                | 606.3                |
| 27  | DUMMY    | -2986.7              | -604.2               | 107 | O240     | 5975                 | 606.3                | 187 | O160     | 1975                 | 606.3                | 267 | O80      | -2025                | 606.3                |
| 28  | DUMMY    | -2920.7              | -604.2               | 108 | O239     | 5925                 | 606.3                | 188 | O159     | 1925                 | 606.3                | 268 | O79      | -2075                | 606.3                |
| 29  | DUMMY    | -2854.7              | -604.2               | 109 | O238     | 5875                 | 606.3                | 189 | O158     | 1875                 | 606.3                | 269 | O78      | -2125                | 606.3                |
| 30  | FRWS3    | -2663                | -604.2               | 110 | O237     | 5825                 | 606.3                | 190 | O157     | 1825                 | 606.3                | 270 | O77      | -2175                | 606.3                |
| 31  | FRWS3    | -2597                | -604.2               | 111 | O236     | 5775                 | 606.3                | 191 | O156     | 1775                 | 606.3                | 271 | O76      | -2225                | 606.3                |
| 32  | FRWS2    | -2189.1              | -604.2               | 112 | O235     | 5725                 | 606.3                | 192 | O155     | 1725                 | 606.3                | 272 | O75      | -2275                | 606.3                |
| 33  | FRWS2    | -2123.1              | -604.2               | 113 | O234     | 5675                 | 606.3                | 193 | O154     | 1675                 | 606.3                | 273 | O74      | -2325                | 606.3                |
| 34  | DUMMY    | -1931.3              | -604.2               | 114 | O233     | 5625                 | 606.3                | 194 | O153     | 1625                 | 606.3                | 274 | O73      | -2375                | 606.3                |
| 35  | DUMMY    | -1865.3              | -604.2               | 115 | O232     | 5575                 | 606.3                | 195 | O152     | 1575                 | 606.3                | 275 | O72      | -2425                | 606.3                |
| 36  | DUMMY    | -1799.3              | -604.2               | 116 | O231     | 5525                 | 606.3                | 196 | O151     | 1525                 | 606.3                | 276 | O71      | -2475                | 606.3                |
| 37  | DUMMY    | -1733.3              | -604.2               | 117 | O230     | 5475                 | 606.3                | 197 | O150     | 1475                 | 606.3                | 277 | O70      | -2525                | 606.3                |
| 38  | DUMMY    | -1667.3              | -604.2               | 118 | O229     | 5425                 | 606.3                | 198 | O149     | 1425                 | 606.3                | 278 | O69      | -2575                | 606.3                |
| 39  | DUMMY    | -1601.3              | -604.2               | 119 | O228     | 5375                 | 606.3                | 199 | O148     | 1375                 | 606.3                | 279 | O68      | -2625                | 606.3                |
| 40  | FRWS1    | -1409.4              | -604.2               | 120 | O227     | 5325                 | 606.3                | 200 | O147     | 1325                 | 606.3                | 280 | O67      | -2675                | 606.3                |
| 41  | FRWS1    | -1343.4              | -604.2               | 121 | O226     | 5275                 | 606.3                | 201 | O146     | 1275                 | 606.3                | 281 | O66      | -2725                | 606.3                |
| 42  | FRWS0    | -935.6               | -604.2               | 122 | O225     | 5225                 | 606.3                | 202 | O145     | 1225                 | 606.3                | 282 | O65      | -2775                | 606.3                |
| 43  | FRWS0    | -869.6               | -604.2               | 123 | O224     | 5175                 | 606.3                | 203 | O144     | 1175                 | 606.3                | 283 | O64      | -2825                | 606.3                |
| 44  | DUMMY    | -877.7               | -604.2               | 124 | O223     | 5125                 | 606.3                | 204 | O143     | 1125                 | 606.3                | 284 | O63      | -2875                | 606.3                |
| 45  | DUMMY    | -811.7               | -604.2               | 125 | O222     | 5075                 | 606.3                | 205 | O142     | 1075                 | 606.3                | 285 | O62      | -2925                | 606.3                |
| 46  | DUMMY    | -545.7               | -604.2               | 126 | O221     | 5025                 | 606.3                | 206 | O141     | 1025                 | 606.3                | 286 | O61      | -2975                | 606.3                |
| 47  | DUMMY    | -479.7               | -604.2               | 127 | O220     | 4975                 | 606.3                | 207 | O140     | 975                  | 606.3                | 287 | O60      | -3025                | 606.3                |
| 48  | DUMMY    | -413.7               | -604.2               | 128 | O219     | 4925                 | 606.3                | 208 | O139     | 925                  | 606.3                | 288 | O59      | -3075                | 606.3                |
| 49  | DUMMY    | -347.7               | -604.2               | 129 | O218     | 4875                 | 606.3                | 209 | O138     | 875                  | 606.3                | 289 | O58      | -3125                | 606.3                |
| 50  | VDD      | -281.7               | -604.2               | 130 | O217     | 4825                 | 606.3                | 210 | O137     | 825                  | 606.3                | 290 | O57      | -3175                | 606.3                |
| 51  | VDD      | -215.7               | -604.2               | 131 | O216     | 4775                 | 606.3                | 211 | O136     | 775                  | 606.3                | 291 | O56      | -3225                | 606.3                |
| 52  | VDD      | -149.7               | -604.2               | 132 | O215     | 4725                 | 606.3                | 212 | O135     | 725                  | 606.3                | 292 | O55      | -3275                | 606.3                |
| 53  | SEL2     | 352.6                | -604.2               | 133 | O214     | 4675                 | 606.3                | 213 | O134     | 675                  | 606.3                | 293 | O54      | -3325                | 606.3                |
| 54  | SEL2     | 418.6                | -604.2               | 134 | O213     | 4625                 | 606.3                | 214 | O133     | 625                  | 606.3                | 294 | O53      | -3375                | 606.3                |
| 55  | SEL1     | 715.1                | -604.2               | 135 | O212     | 4575                 | 606.3                | 215 | O132     | 575                  | 606.3                | 295 | O52      | -3425                | 606.3                |
| 56  | SEL1     | 781.1                | -604.2               | 136 | O211     | 4525                 | 606.3                | 216 | O131     | 525                  | 606.3                | 296 | O51      | -3475                | 606.3                |
| 57  | DOC      | 1138.2               | -604.2               | 137 | O210     | 4475                 | 606.3                | 217 | O130     | 475                  | 606.3                | 297 | O50      | -3525                | 606.3                |
| 58  | DOC      | 1204.2               | -604.2               | 138 | O209     | 4425                 | 606.3                | 218 | O129     | 425                  | 606.3                | 298 | O49      | -3575                | 606.3                |
| 59  | DUMMY    | 1375.8               | -604.2               | 139 | O208     | 4375                 | 606.3                | 219 | O128     | 375                  | 606.3                | 299 | O48      | -3625                | 606.3                |
| 60  | DUMMY    | 1441.8               | -604.2               | 140 | O207     | 4325                 | 606.3                | 220 | O127     | 325                  | 606.3                | 300 | O47      | -3675                | 606.3                |
| 61  | DUMMY    | 1507.8               | -604.2               | 141 | O206     | 4275                 | 606.3                | 221 | O126     | 275                  | 606.3                | 301 | O46      | -3725                | 606.3                |
| 62  | DUMMY    | 1573.8               | -604.2               | 142 | O205     | 4225                 | 606.3                | 222 | O125     | 225                  | 606.3                | 302 | O45      | -3775                | 606.3                |
| 63  | DUMMY    | 1639.8               | -604.2               | 143 | O204     | 4175                 | 606.3                | 223 | O124     | 175                  | 606.3                | 303 | O44      | -3825                | 606.3                |
| 64  | DUMMY    | 1705.8               | -604.2               | 144 | O203     | 4125                 | 606.3                | 224 | O123     | 125                  | 606.3                | 304 | O43      | -3875                | 606.3                |
| 65  | DUMMY    | 1771.8               | -604.2               | 145 | O202     | 4075                 | 606.3                | 225 | O122     | 75                   | 606.3                | 305 | O42      | -3925                | 606.3                |
| 66  | DUMMY    | 1837.8               | -604.2               | 146 | O201     | 4025                 | 606.3                | 226 | O121     | 25                   | 606.3                | 306 | O41      | -3975                | 606.3                |
| 67  | DSPOF    | 2078                 | -604.2               | 147 | O200     | 3975                 | 606.3                | 227 | O120     | -25                  | 606.3                | 307 | O40      | -4025                | 606.3                |
| 68  | DSPOF    | 2144                 | -604.2               | 148 | O199     | 3925                 | 606.3                | 228 | O119     | -75                  | 606.3                | 308 | O39      | -4075                | 606.3                |
| 69  | SHL      | 2440.6               | -604.2               | 149 | O198     | 3875                 | 606.3                | 229 | O118     | -125                 | 606.3                | 309 | O38      | -4125                | 606.3                |
| 70  | SHL      | 2506.6               | -604.2               | 150 | O197     | 3825                 | 606.3                | 230 | O117     | -175                 | 606.3                | 310 | O37      | -4175                | 606.3                |
| 71  | DUMMY    | 2746.8               | -604.2               | 151 | O196     | 3775                 | 606.3                | 231 | O116     | -225                 | 606.3                | 311 | O36      | -4225                | 606.3                |
| 72  | DUMMY    | 2812.8               | -604.2               | 152 | O195     | 3725                 | 606.3                | 232 | O115     | -275                 | 606.3                | 312 | O35      | -4275                | 606.3                |
| 73  | VSS      | 2878.8               | -604.2               | 153 | O194     | 3675                 | 606.3                | 233 | O114     | -325                 | 606.3                | 313 | O34      | -4325                | 606.3                |
| 74  | VSS      | 2944.8               | -604.2               | 154 | O193     | 3625                 | 606.3                | 234 | O113     | -375                 | 606.3                | 314 | O33      | -4375                | 606.3                |
| 75  | VSS      | 3010.8               | -604.2               | 155 | O192     | 3575                 | 606.3                | 235 | O112     | -425                 | 606.3                | 315 | O32      | -4425                | 606.3                |
| 76  | DUMMY    | 3076.8               | -604.2               | 156 | O191     | 3525                 | 606.3                | 236 | O111     | -475                 | 606.3                | 316 | O31      | -4475                | 606.3                |
| 77  | DUMMY    | 3142.8               | -604.2               | 157 | O190     | 3475                 | 606.3                | 237 | O110     | -525                 | 606.3                | 317 | O30      | -4525                | 606.3                |
| 78  | DUMMY    | 3208.8               | -604.2               | 158 | O189     | 3425                 | 606.3                | 238 | O109     | -575                 | 606.3                | 318 | O29      | -4575                | 606.3                |
| 79  | DUMMY    | 3274.8               | -604.2               | 159 | O188     | 3375                 | 606.3                | 239 | O108     | -625                 | 606.3                | 319 | O28      | -4625                | 606.3                |
| 80  | DUMMY    | 3340.8               | -604.2               | 160 | O187     | 3325                 | 606.3                | 240 | O107     | -675                 | 606.3                | 320 | O27      | -4675                | 606.3                |

Note: Leave DUMMY pads open.

| No. | Pad name | x-coordinate<br>[μm] | y-coordinate<br>[μm] | No. | Pad name | x-coordinate<br>[μm] | y-coordinate<br>[μm] | No. | Pad name | x-coordinate<br>[μm] | y-coordinate<br>[μm] |
|-----|----------|----------------------|----------------------|-----|----------|----------------------|----------------------|-----|----------|----------------------|----------------------|
| 321 | O26      | -4725                | 606.3                | 331 | O16      | -5225                | 606.3                | 341 | O6       | -5725                | 606.3                |
| 322 | O25      | -4775                | 606.3                | 332 | O15      | -5275                | 606.3                | 342 | O5       | -5775                | 606.3                |
| 323 | O24      | -4825                | 606.3                | 333 | O14      | -5325                | 606.3                | 343 | O4       | -5825                | 606.3                |
| 324 | O23      | -4875                | 606.3                | 334 | O13      | -5375                | 606.3                | 344 | O3       | -5875                | 606.3                |
| 325 | O22      | -4925                | 606.3                | 335 | O12      | -5425                | 606.3                | 345 | O2       | -5925                | 606.3                |
| 326 | O21      | -4975                | 606.3                | 336 | O11      | -5475                | 606.3                | 346 | O1       | -5975                | 606.3                |
| 327 | O20      | -5025                | 606.3                | 337 | O10      | -5525                | 606.3                | 347 | DUMMY    | -6025                | 606.3                |
| 328 | O19      | -5075                | 606.3                | 338 | O9       | -5575                | 606.3                | 348 | DUMMY    | -6075                | 606.3                |
| 329 | O18      | -5125                | 606.3                | 339 | O8       | -5625                | 606.3                |     |          |                      |                      |
| 330 | O17      | -5175                | 606.3                | 340 | O7       | -5675                | 606.3                |     |          |                      |                      |

Note: Leave DUMMY pads open.

Alignment Mark Information

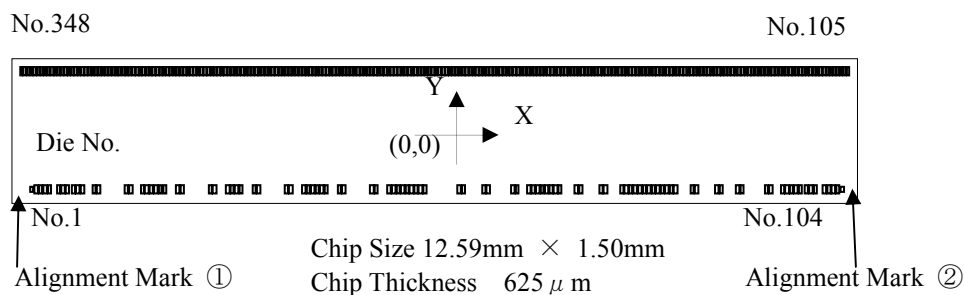

Alignment Mark①  
Center Coordinate (-6074.4, -588.1)

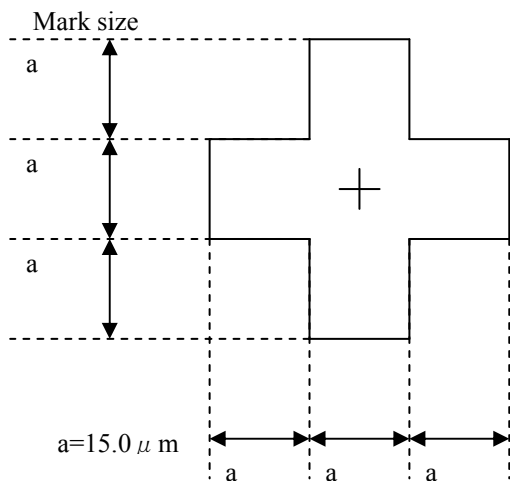

Alignment Mark②  
Center Coordinate (6074.4, -588.1)

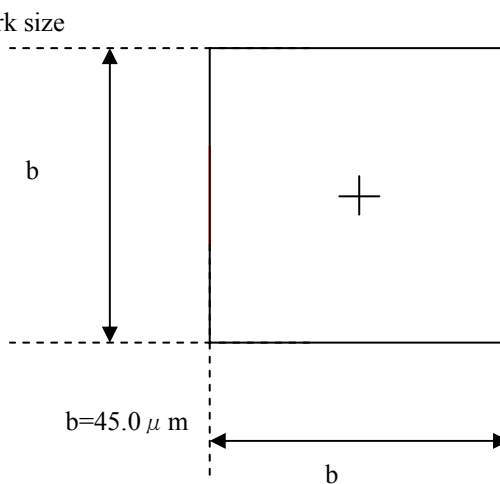

7.2 Pin Configuration (TCP: ML9460ADVVA)

TOP VIEW

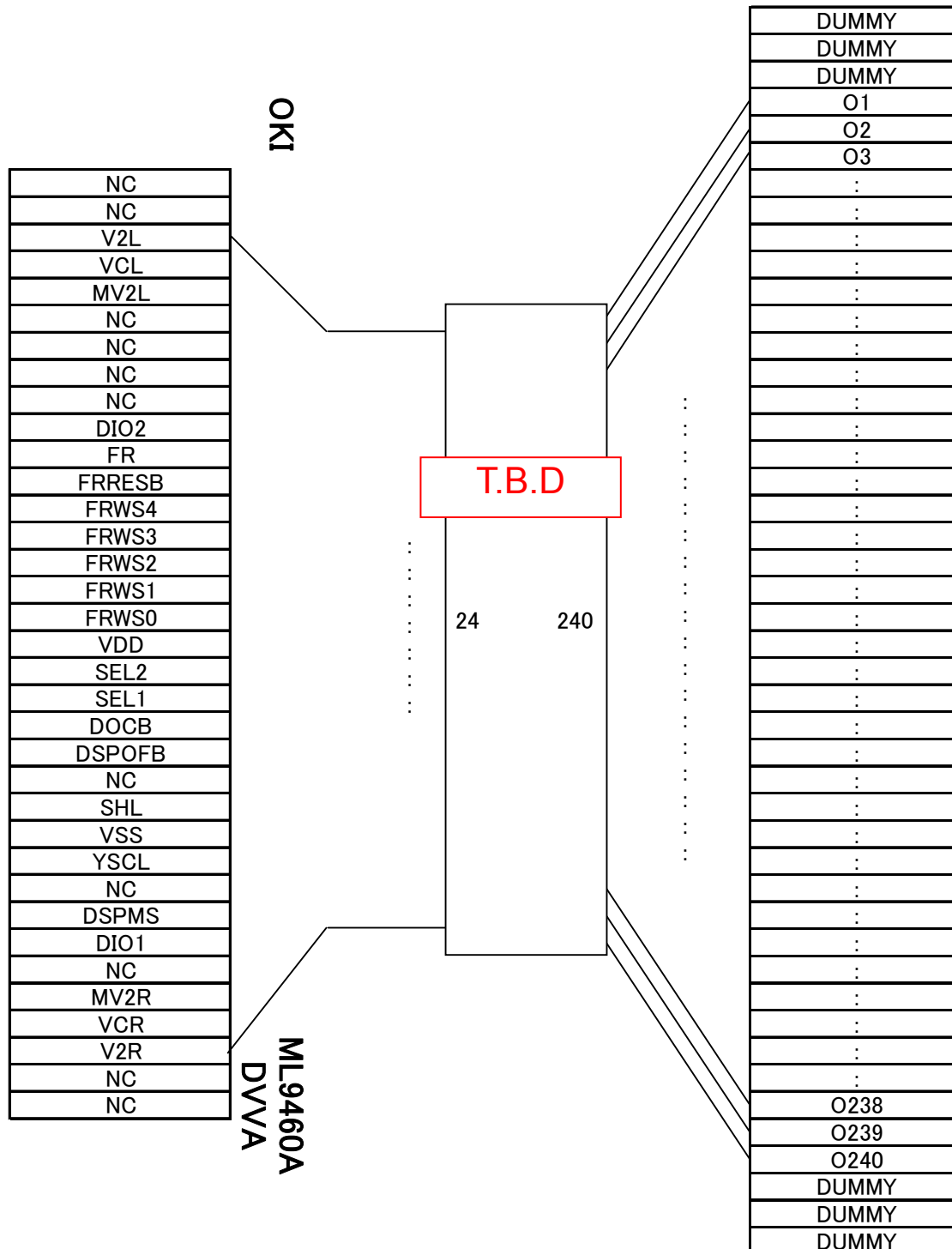

The drawing shown does not specify the exact outline of the TCP; it only specifies the pin layout.

### 8. Application Circuit (With External Components Connected)

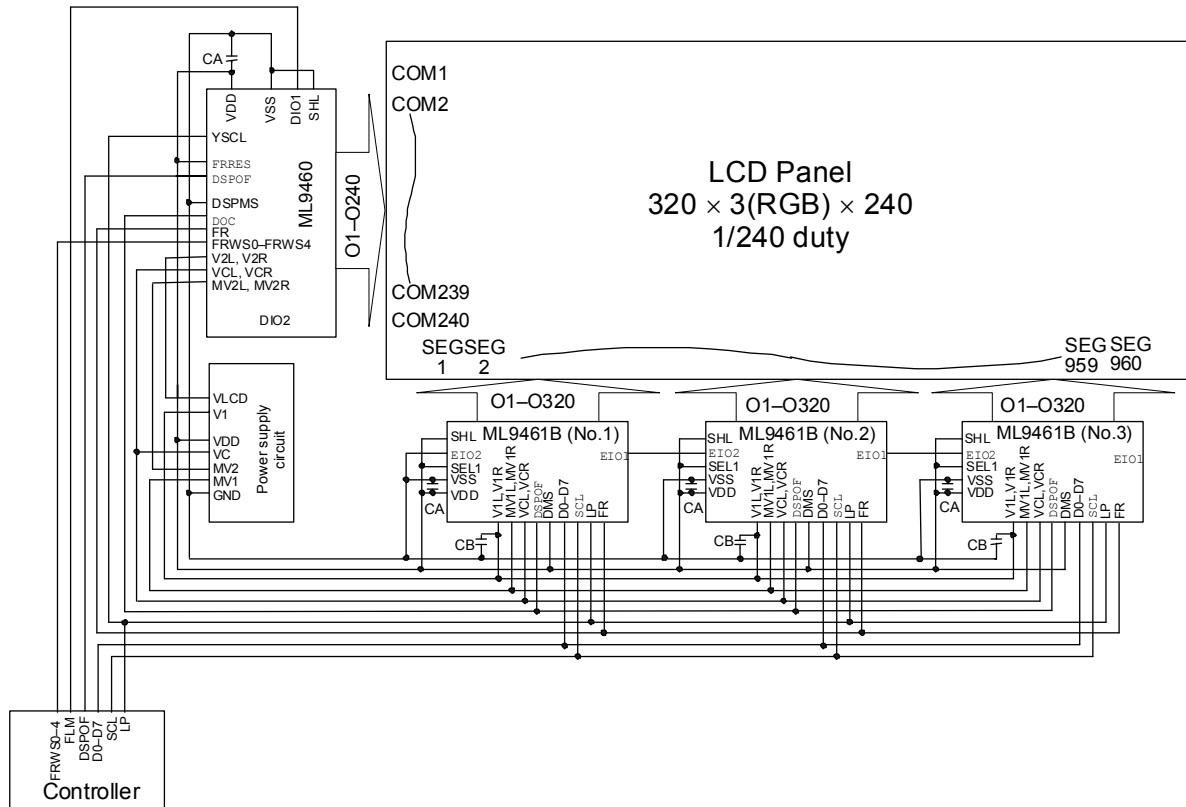

Insert a capacitor CA, CB specified in the Recommended Operating Conditions (Guaranteed Operating Range). It is recommended that 0.1  $\mu$ F CA capacitors (JIS (Japanese Industrial Standards) FJ(F) equivalent) be used.

## Revision History

| Document No. | Date         | Page             |                 | Description                           |
|--------------|--------------|------------------|-----------------|---------------------------------------|
|              |              | Previous Edition | Current Edition |                                       |
| PEDL9460-01  | May 21, 2007 | –                | –               | Preliminary edition 1                 |
| PEDL9460-02  | Dec 5, 2007  | 1                | 1               | Au Bump Chip product name DVWA→CVWA   |
|              |              | 13               | 13              | Additional comment.                   |
|              |              | –                | 23              | Additional 7.2 Pin Configuration.     |
| PEDL9460-03  | Dec 17,2008  | 23               | 24              | Changed Application Circuit.          |
|              |              | –                | –               | Changed to OKI Semiconductor's format |
| PEDL9460-03  | Dec 17,2008  | 1,7,24           | 1,7,24          | ML9461→ML9461B                        |
|              |              | –                | –               | Final edition 1                       |
| FEDL9460-01  | Jan 29,2009  | 2                | 2               | Additional comment for FRRES pin      |
|              |              | –                | 4               | Additional                            |
|              |              | 13               | 14              | 2.2 Inupt and Output Configuration    |
|              |              | 22               | 23              | Changed explanation                   |
|              |              |                  |                 | Additional Alignment Mark Information |

NOTICE

No copying or reproduction of this document, in part or in whole, is permitted without the consent of LAPIS Semiconductor Co., Ltd.

The content specified herein is subject to change for improvement without notice.

The content specified herein is for the purpose of introducing LAPIS Semiconductor's products (hereinafter "Products"). If you wish to use any such Product, please be sure to refer to the specifications, which can be obtained from LAPIS Semiconductor upon request.

Examples of application circuits, circuit constants and any other information contained herein illustrate the standard usage and operations of the Products. The peripheral conditions must be taken into account when designing circuits for mass production.

Great care was taken in ensuring the accuracy of the information specified in this document. However, should you incur any damage arising from any inaccuracy or misprint of such information, LAPIS Semiconductor shall bear no responsibility for such damage.

The technical information specified herein is intended only to show the typical functions of and examples of application circuits for the Products. LAPIS Semiconductor does not grant you, explicitly or implicitly, any license to use or exercise intellectual property or other rights held by LAPIS Semiconductor and other parties. LAPIS Semiconductor shall bear no responsibility whatsoever for any dispute arising from the use of such technical information.

The Products specified in this document are intended to be used with general-use electronic equipment or devices (such as audio visual equipment, office-automation equipment, communication devices, electronic appliances and amusement devices).

The Products specified in this document are not designed to be radiation tolerant.

While LAPIS Semiconductor always makes efforts to enhance the quality and reliability of its Products, a Product may fail or malfunction for a variety of reasons.

Please be sure to implement in your equipment using the Products safety measures to guard against the possibility of physical injury, fire or any other damage caused in the event of the failure of any Product, such as derating, redundancy, fire control and fail-safe designs. LAPIS Semiconductor shall bear no responsibility whatsoever for your use of any Product outside of the prescribed scope or not in accordance with the instruction manual.

The Products are not designed or manufactured to be used with any equipment, device or system which requires an extremely high level of reliability the failure or malfunction of which may result in a direct threat to human life or create a risk of human injury (such as a medical instrument, transportation equipment, aerospace machinery, nuclear-reactor controller, fuel-controller or other safety device). LAPIS Semiconductor shall bear no responsibility in any way for use of any of the Products for the above special purposes. If a Product is intended to be used for any such special purpose, please contact a ROHM sales representative before purchasing.

If you intend to export or ship overseas any Product or technology specified herein that may be controlled under the Foreign Exchange and the Foreign Trade Law, you will be required to obtain a license or permit under the Law.