

---

# MSM7732A-01

---

## Audio CODEC

---

### GENERAL DESCRIPTION

The MSM7732A is a single-channel full duplex CODEC CMOS IC which performs mutual transcoding between the analog voice band signals and 64 kbps PCM serial data.

This device performs such functions as DTMF tone and several types of tone generation, transmit/receive data mute and gain control, and side tone path.

### FEATURES

- Single 3 V power supply operation  $V_{DD}$ : 2.4 V to 3.3 V
- PCM interface data format :  $\mu$ -law/A-law/linear (2's complement) selectable
- PCM interface timing : long frame synchronous timing/short frame synchronous timing
- Full-duplex single channel operation
- Serial PCM transmission data rate: 64 kbps to 2048 kbps
- Low power consumption
  - Operating mode: 15 mW typ. ( $V_{DD} = 3.0$  V)
  - Power-down mode: 3  $\mu$ W typ. ( $V_{DD} = 3.0$  V)
- Master clock frequency: 2.048 MHz
- Analog output stage
  - 35 mW drive for receiver speaker (differential drive of 32  $\Omega$ )--Gain adjustable
  - 66 mW drive for receiver speaker (differential drive of 30  $\Omega$ )--Gain adjustable
  - 6.6 mW drive for earphone speaker (single drive of 32  $\Omega$ ) --Gain adjustable
- Transmit/receive mute, transmit/receive programmable gain control
- Side tone path with programmable attenuation (8-step adjustment level)
- Built-in DTMF tone generator
- Built-in various ringing/function tone generator
- Built-in various ring back tone generator
- Serial MCU interface control: 3 bit
- Built-in transmit voice signal detector
- Built-in op amps and analog switches for various analog interface
- Package options :
  - 30-pin plastic SSOP (SSOP30-P-56-0.65-K) (MSM7732A-01 MB)
  - 48-pin plastic TQFP (TQFP48-P-0707-0.50-K) (MSM7732A-01 TB)
  - 48-pin plastic BGA (P-LFBGA48-0707-0.8) (MSM7732A-01 LA)

BLOCK DIAGRAM

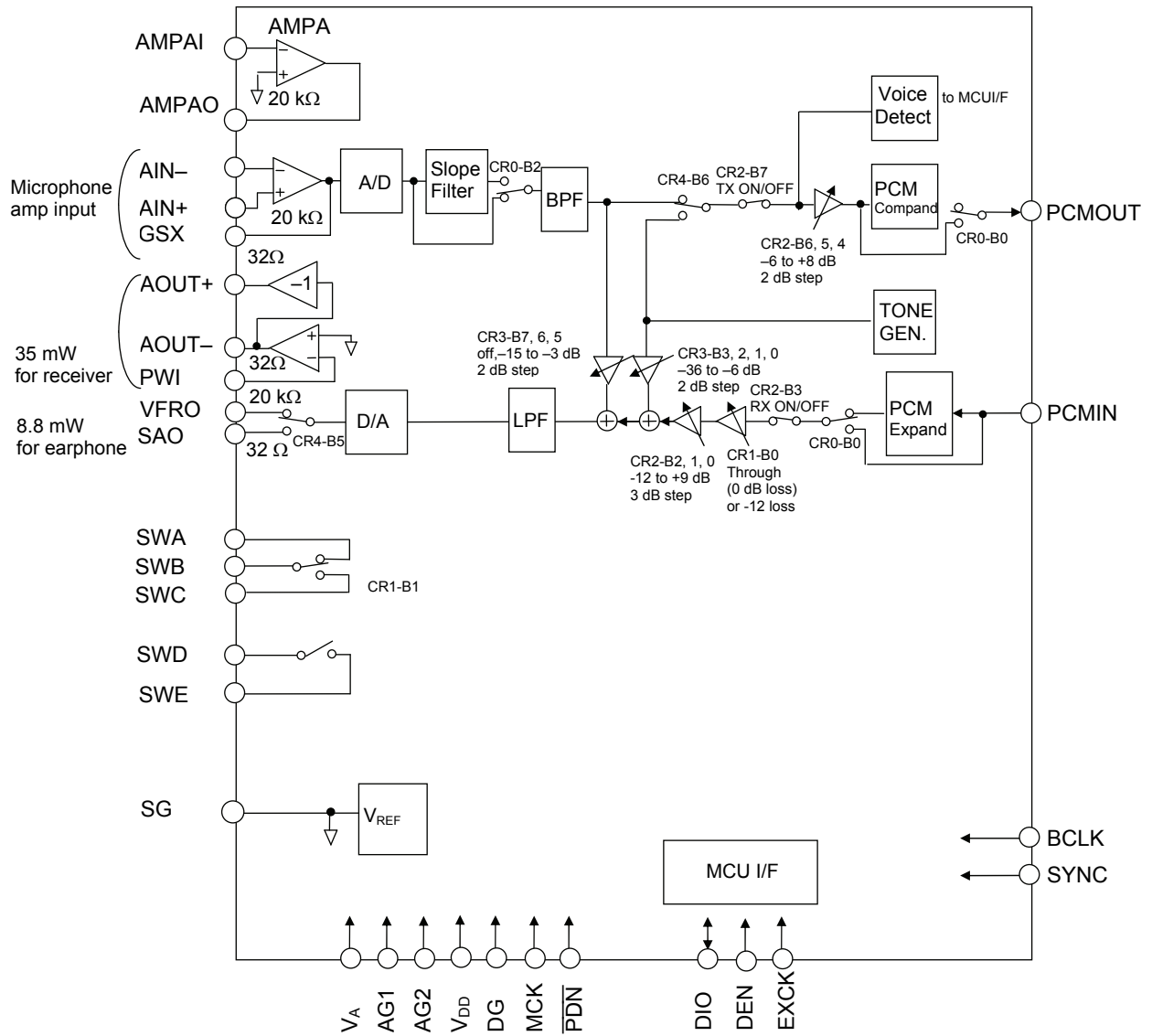

**PIN CONFIGURATION (TOP VIEW)**

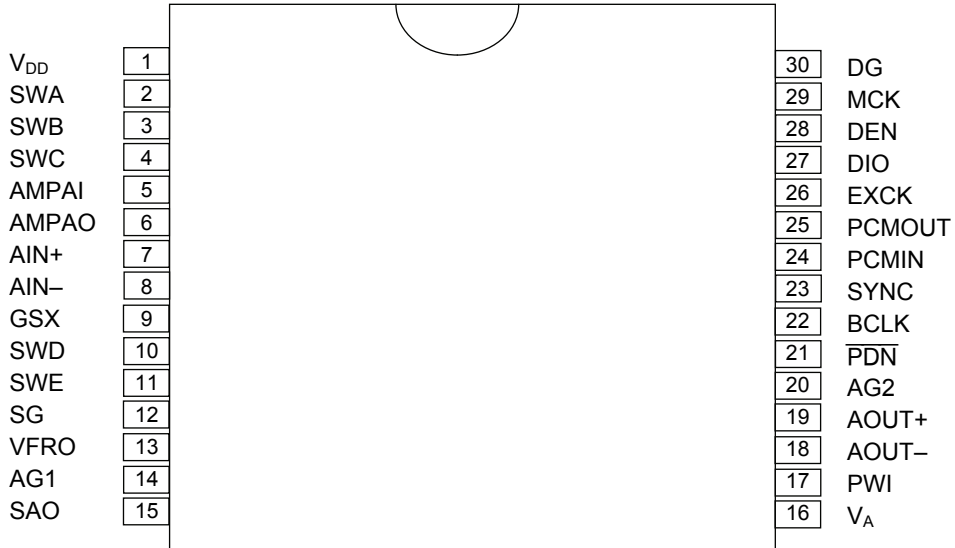

**30-Pin Plastic SSOP**

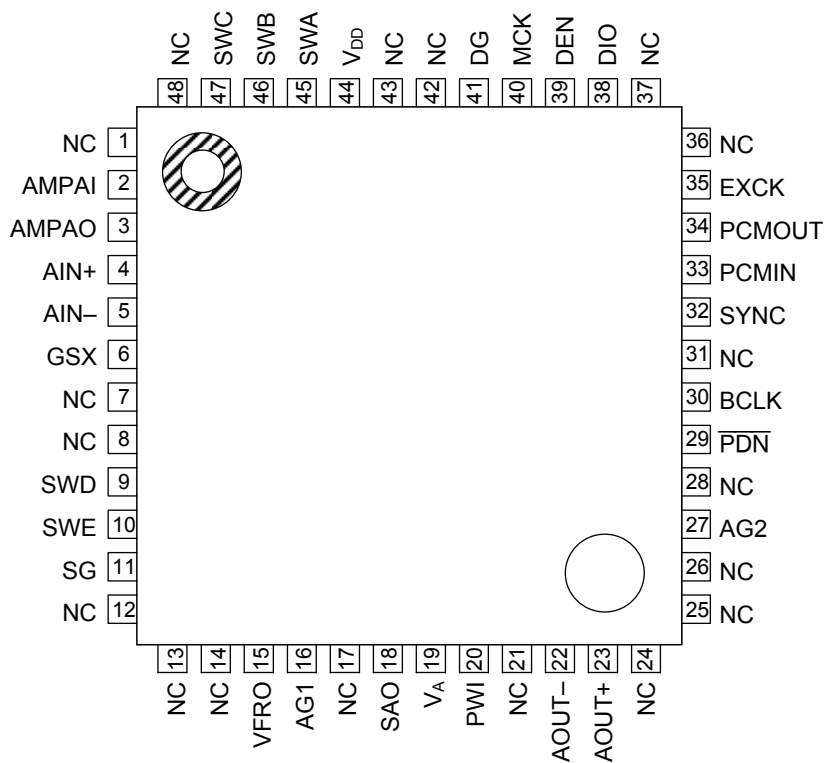

NC: No Connection

**48-Pin Plastic TQFP**

	8	7	6	5	4	3	2	1
H	AG2	AOUT+	AOUT-	PWI	V <sub>A</sub>	SAO	AG1	VFRO
G	PDN	NC	NC	NC	NC	NC	SG	SWE
F	BCLK	NC					NC	SWD
E	SYNC	NC					NC	GSX
D	PCMIN	NC					NC	AIN-
C	PCMOUT	NC					NC	AIN+
B	EXCK	DIO	NC	NC	NC	NC	NC	AMPAO
A	DEN	MCK	DG	V <sub>DD</sub>	SWA	SWB	SWC	AMPAI

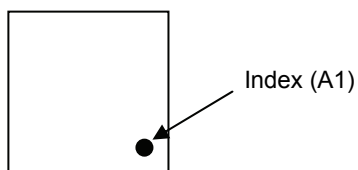

NC: No Connection

48-Pin Plastic LGA  
48-Pin Plastic BGA

## PIN DESCRIPTION

Pin	Symbol	Type	Description
1	V <sub>DD</sub>	—	Power supply (3.0 V)
2	SWA	IO	Analog switch A
3	SWB	IO	Analog switch B
4	SWC	IO	Analog switch C
5	AMPAI	I	Amplifier A inverting input
6	AMPAO	O	Amplifier A output
7	AIN+	I	Transmit side amplifier non-inverting input
8	AIN-	I	Transmit side amplifier inverting input
9	GSX	O	Transmit side amplifier output
10	SWD	IO	Analog switch D
11	SWE	IO	Analog switch E
12	SG	O	Analog signal ground (1.4 V)
13	VFRO	O	Receive side voice output
14	AG1	—	Analog ground 1 (0 V)
15	SAO	O	Receive side sounder amplifier output
16	V <sub>A</sub>	—	Analog power supply (3.0 V)
17	PWI	I	Receive side voice amplifier input
18	AOUT-	O	Receive side voice amplifier output -
19	AOUT+	O	Receive side voice amplifier output +
20	AG2	—	Analog ground 2 (0 V)
21	$\overline{\text{PDN}}$	I	Power down control input
22	BCLK	I	PCM data shift clock input
23	SYNC	I	PCM data shift sync signal input
24	PCMIN	I	Receive side PCM signal input
25	PCMOUT	O	Transmit side PCM signal output
26	EXCK	I	Clock signal input for control register
27	DIO	IO	Address and data input or output for control register
28	DEN	I	Enable signal input for control register
29	MCK	I	Master clock input (2.048 MHz)
30	DG	—	Digital ground (0 V)

## PIN FUNCTIONAL DESCRIPTION

AIN+, AIN-, GSX

Transmit analog inputs and the output for transmit gain adjustment.

AIN- connects to inverting input of the internal transmit amplifier. AIN+ connects to non-inverting input of the internal transmit amplifier. GSX connects to the internal transmit amplifier output. Refer to Figure 1 for gain adjustment.

VFRO, SAO, AOUT+, AOUT-, PWI

Receive analog outputs and the outputs for receive gain adjustment.

VFRO is the receive filter output for the voice signal. SAO is the receive filter output for an acoustic component of the sound tone. SAO can directly drive  $32\ \Omega$  load. AOUT+ and AOUT- are differential analog signal outputs which can directly drive a  $32\ \Omega$  load. Refer to Figure 1.

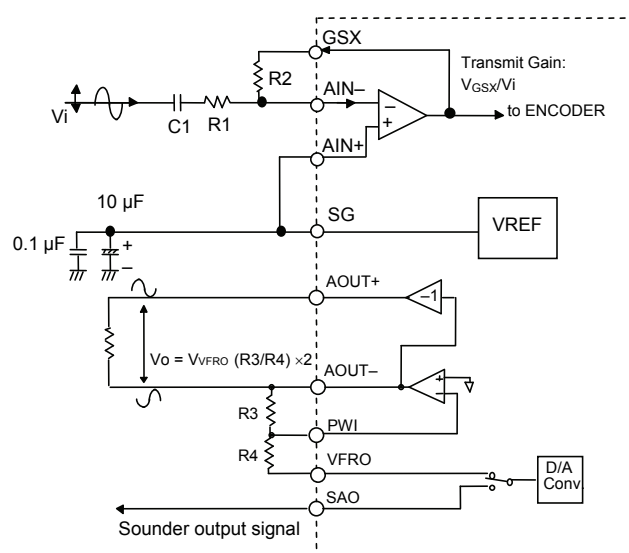

**Figure 1 Analog Input/Output Interface**

**SG**

Analog signal ground.

The output voltage of this pin is approximately 1.4 V. Put the bypass capacitors (10  $\mu$ F in parallel with 0.1  $\mu$ F ceramic type) between this pin and AG to get the specified noise characteristics. During power-down, this output voltage is 0 V.

**AMPAI, AMPAO**

Used for amplifier A. The pin AMPAI is connected to the amplifier A inverting input, and the pin AMPAO is connected to the amplifier A output.

**SWA, SWB, SWC**

Used for the internal analog switch. The pin SWB connects to the pin SWA or the pin SWC. This is controlled by CR1-B1.

**SWD, SWE**

Used for the internal analog switch. The pin SWD connects to the pin SWE or not. This is controlled by CR1-B2.

**V<sub>DD</sub>, V<sub>A</sub>**

+3 V power supply for analog. V<sub>DD</sub> is the digital power supply. V<sub>A</sub> is the analog power supply. Since these pins are separated in the device, connect them as close as possible on the PCB.

**DG, AG1, AG2**

Ground. DG is the digital system ground. AG1 and AG2 are connected to the analog system ground. The DG pin must be kept as close as possible to AG1 and AG2 on the PCB.

 **$\overline{\text{PDN}}$** 

Power down and reset control input.

When set to digital "0", the system changes to the power down state and control registers are reset. Since the power down mode is controlled by a logical OR with CR0-B5 of the control register, set CR0-B5 to logic "0" when using this pin.

Be sure to reset the control registers by executing this power down to keep this pin to digital "0" level for 200 ns or longer after the power is turned on and V<sub>DD</sub> exceeds 2.4 V.

**MCK**

Master clock input.

The frequency must be 2.048 MHz. MCK can be asynchronous with SYNC and BCLK.

**BCLK**

Shift clock input for the PCM data.

The frequency is set in the range of 64 kHz to 2048 kHz.

### SYNC

8 kHz synchronous signal input for transmit and receive PCM data.  
Synchronize this signal with BCLK signal. Refer to Figure 2.

### PCMOUT

Transmit PCM data output.

This PCM output signal is output from MSB synchronously with the rising edge of BCLK and SYNC. Refer to Figure 2. This is a logic output pin so that external pull-up is not required. This pin outputs logic "L" except during effective PCM data bits, and outputs logic "H" during power-down.

### PCMIN

Receive PCM data input.

This PCM input signal is shifted in on the falling edge of BCLK and is input from MSB.  
Refer to Figure 2.

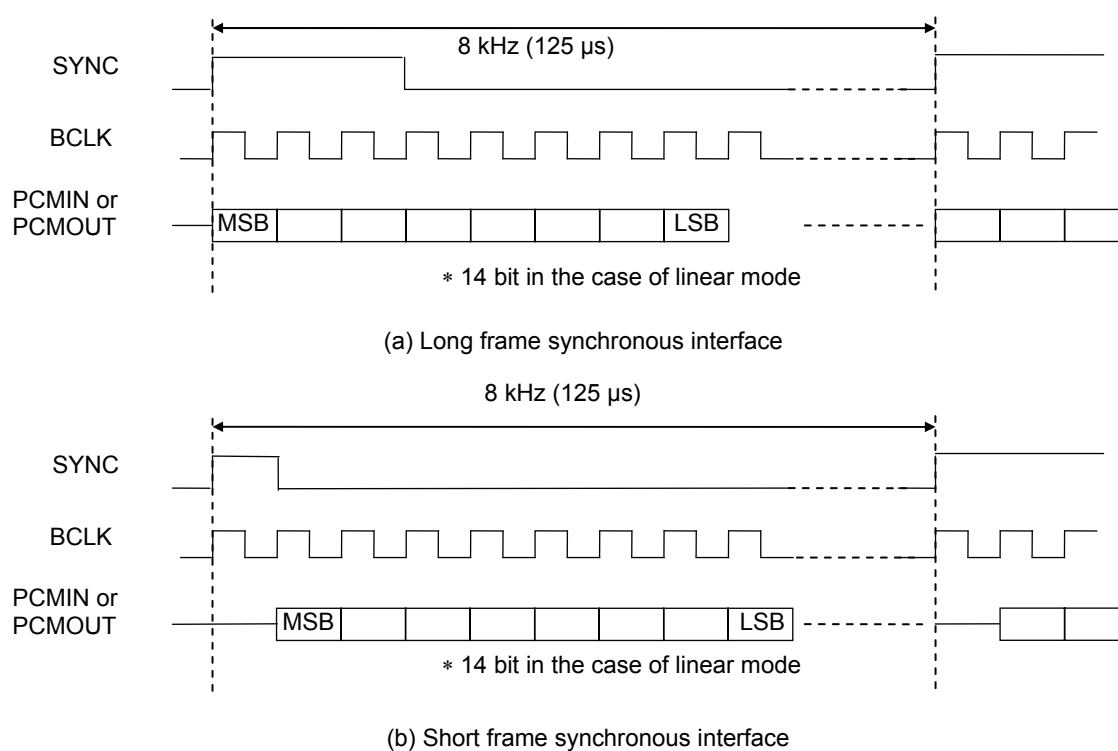

**Figure 2 PCM Interface Basic Timing Diagram**

## DEN, EXCK, DIO

Serial control ports for MCU interface.

Reading and writing data is performed by an external MCU through these pins. Eight registers with eight bits are provided on the devices.

DEN is the "Enable" control signal input, EXCK is the data shift clock input, and DIO is the address and data input or output. Figure 3 shows the input or output timing diagram.



(a) Write Data Timing Diagram

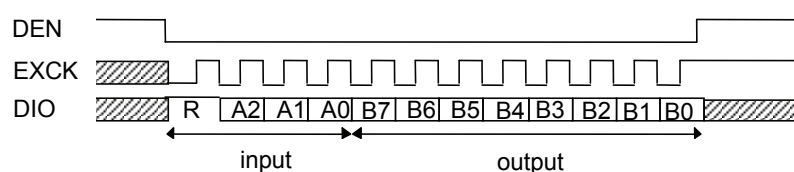

(b) Read Data Timing Diagram

**Figure 3 MCU Interface Input/Output Timing**

Table 1 shows the register map.

**Table 1**

Name	Address			Control and Detect Data								R/W
	A2	A1	A0	B7	B6	B5	B4	B3	B2	B1	B0	
CR0	0	0	0	A/ $\mu$ SEL	PON AOUT	PDN ALL	PDN TX	PDN RX	SLP	SLP SEL	LNR	R/W
CR1	0	0	1	—	—	—	—	SHORT FRAME	SW D/E	SW C/A	RX PAD	R/W
CR2	0	1	0	TX ON/OFF	TX GAIN2	TX GAIN1	TX GAIN0	RX ON/OFF	RX GAIN2	RX GAIN1	RX GAIN0	R/W
CR3	0	1	1	Side Tone GAIN2	Side Tone GAIN1	Side Tone GAIN0	TONE ON/OFF	TONE GAIN3	TONE GAIN2	TONE GAIN1	TONE GAIN0	R/W
CR4	1	0	0	DTMF/ OTHERS SEL	TONE SEND	SAO/ VFRO	TONE4	TONE3	TONE2	TONE1	TONE0	R/W
CR5	1	0	1	—	—	—	—	—	—	—	—	R/W
CR6	1	1	0	VOX ON/OFF	ON LVL1	ON LVL0	—	—	—	—	—	R/W
CR7	1	1	1	VOX OUT	TX NOISE LVL1	TX NOISE LVL0	—	—	—	—	—	R

R/W : Read/Write enable R : Read only register

**ABSOLUTE MAXIMUM RATINGS**

Parameter	Symbol	Condition	Rating	Unit
Power Supply Voltage	$V_{DD}$	—	-0.3 to +5.0	V
Analog Input Voltage	$V_{AIN}$	—	-0.3 to $V_{DD}+0.3$	V
Digital Input Voltage	$V_{DIN}$	—	-0.3 to $V_{DD}+0.3$	V
Storage Temperature	$T_{STG}$	—	-55 to +150	°C

**RECOMMENDED OPERATING CONDITIONS**

Parameter	Symbol	Condition	Min.	Typ.	Max.	Unit
Power Supply Voltage	$V_{DD}$	Voltage must be fixed	+2.4	+3.0	+3.3	V
Operating Temperature	$T_a$	—	-40	—	+85	°C
Input High Voltage	$V_{IH}$	To all digital input pins	$0.7 \times V_{DD}$	—	$V_{DD}$	V
Input Low Voltage	$V_{IL}$	To all digital input pins	0	—	$0.16 \times V_{DD}$	V
Digital Input Rise Time	$t_{ir}$	To all digital input pins	—	—	50	ns
Digital Input Fall Time	$t_{if}$	To all digital input pins	—	—	50	ns
Digital Output Load	$C_{DL}$	To all digital output pins	—	—	100	pF
Bypass Capacitor for SG	$C_{SG}$	Between SG and AG	10+0.1	—	—	μF
Master Clock Frequency	$F_{MCK}$	MCK	-0.01%	2.048	0.01%	MHz
Bit Clock Frequency	$F_{BCK1}$	BCLK (A/μ-law)	64	—	2048	kHz
	$F_{BCK2}$	BCLK (Linear)	128	—	2048	kHz
Synchronous Signal Frequency	$F_{SYNC}$	SYNC	-0.01%	8.0	0.01%	kHz
Clock Duty Ratio	$D_{CLK}$	MCK, BCLK, EXCK	40	50	60	%
Sync Pulse Setting Time	$T_{SB}$	SYNC → BCLK	-100	—	100	ns
	$T_{BS}$	BCLK → SYNC	100	—	—	ns
Synchronous Signal Width	$t_{WS}$	SYNC	1BCLK	—	100	μs

**ELECTRICAL CHARACTERISTICS****DC Characteristics** $(V_{DD} = 2.4 \text{ V to } 3.3 \text{ V}, T_a = -40^\circ\text{C to } +85^\circ\text{C})$ 

Parameter	Symbol	Condition	Min.	Typ.	Max.	Unit
Power Supply Current	$I_{DD1}$	Operation Mode No Signal ( $V_{DD} = 3.0 \text{ V}$ )	0	5.0	11.0	mA
	$I_{DD2}$	Operation Mode No Signal ( $V_{DD} = 3.0 \text{ V}$ ) AOUT+, AOUT- or SAO is active	0	9.0	20.0	mA
	$I_{DD3}$	Power Down Mode ( $V_{DD} = 3.0 \text{ V}, T_a = 25^\circ\text{C}$ )	0	1.0	10	$\mu\text{A}$
Input Leakage Voltage	$I_{IH}$	$V_I = V_{DD}$	—	—	2.0	$\mu\text{A}$
	$I_{IL}$	$V_I = 0 \text{ V}$	—	—	0.5	$\mu\text{A}$
Output High Voltage	$V_{OH}$	$I_{OH} = 0.4 \text{ mA}$	$0.5 \times V_{DD}$	—	$V_{DD}$	V
Output Low Voltage	$V_{OL}$	$I_{OL} = -1.2 \text{ mA}$	0	0.2	0.4	V
Input Capacitance	$C_{IN}$	—	—	5	—	pF

**Analog Interface Characteristics** $(V_{DD} = 2.4 \text{ V to } 3.3 \text{ V}, T_a = -40^\circ\text{C to } +85^\circ\text{C})$ 

Parameter	Symbol	Condition	Min.	Typ.	Max.	Unit
Input Resistance	$R_{INX}$	AMP AI, AIN+, AIN-, PWI	10	—	—	$\text{M}\Omega$
Output Load Resistance	$R_{LGX1}$	AMP AO, GSX, VFRO	20	—	—	$\text{k}\Omega$
	$R_{LGX2}$	SAO, AOUT+, AOUT-	32	—	—	$\Omega$
Output Load Capacitance	$C_{LGX}$	Analog output pins	—	—	100	pF
Output Amplitude	$V_{O1}$	AMP AO, GSX, VFRO $R_L = 20 \text{ k}\Omega$ SAO $R_L = 32\Omega$	—	—	* <sup>1</sup> 1.3	V <sub>PP</sub>
	$V_{O2}$	AOUT+, AOUT- Differential output $V_{DD} = 2.7 \text{ to } 3.3 \text{ V}$ $R_L = 32\Omega$	—	—	3.0	V <sub>PP</sub>
	* <sup>2</sup> $V_{O3}$	AOUT+, AOUT- Differential output $V_{DD} = 3.0 \text{ V}$ $R_L = 30\Omega$	—	—	3.98	V <sub>PP</sub>
Total Harmonic Distortion	THD <sub>1</sub>	SAO, AOUT+, AOUT- ( $V_{O1}, V_{O2}$ )	—	—	1.0	%
	* <sup>2</sup> THD <sub>2</sub>	AOUT+, AOUT- ( $V_{O3}$ )	—	1.0	—	%
Input Offset Voltage	$V_{OFGX1}$	AMP AO, GSX	-20	—	20	mV
	$V_{OFGX2}$	VFRO, SAO, AOUT+, AOUT-	-100	—	100	mV
SG Output Voltage	$V_{SG}$	SG	—	1.4	—	V
SG Output Impedance	$R_{SG}$	SG	—	40	80	$\text{k}\Omega$
Internal Switch ON Impedance	$R_{SW}$	All internal switches	—	—	300	$\Omega$

\*<sup>1</sup> -7.7 dBm (600 $\Omega$ ) = 0 dBm<sub>0</sub>, +3.17 dBm<sub>0</sub> = 1.3 V<sub>PP</sub>\*<sup>2</sup> Expected value

## AC Characteristics

(V<sub>DD</sub> = 2.4 V to 3.3 V, Ta = -40°C)

Parameter	Symbol	Condition			Min.	Typ.	Max.	Unit
		Freq. (Hz)	Level (dBm0)	Others				
Transmit Frequency Response	L <sub>oss</sub> T1	0 to 60	0	—	25	—	—	dB
	L <sub>oss</sub> T2	300 to 3000			-0.15	—	0.20	dB
	L <sub>oss</sub> T3	1020			Reference			dB
	L <sub>oss</sub> T4	3300			-0.15	—	0.80	dB
	L <sub>oss</sub> T5	3400			0	—	0.80	dB
	L <sub>oss</sub> R6	3968.75			13	—	—	dB
Receive Frequency Response	L <sub>oss</sub> R1	0 to 3000	0	—	-0.15	—	0.20	dB
	L <sub>oss</sub> R2	1020			Reference			dB
	L <sub>oss</sub> R3	3300			-0.15	—	0.80	dB
	L <sub>oss</sub> R4	3400			0	—	0.80	dB
	L <sub>oss</sub> R5	3968.75			13	—	—	dB
Transmit Signal to Distortion Ratio	SD T1	1020	3	(*1)	35	—	—	dB
	SD T2		0		35	—	—	dB
	SD T3		-30		35	—	—	dB
	SD T4		-40		28	—	—	dB
	SD T5		-45		23	—	—	dB
Receive Signal to Distortion Ratio	SD R1	1020	3	(*1)	35	—	—	dB
	SD R2		0		35	—	—	dB
	SD R3		-30		35	—	—	dB
	SD R4		-40		28	—	—	dB
	SD R5		-45		23	—	—	dB
Transmit Gain Tracking	GT T1	1020	3	—	-0.2	—	0.2	dB
	GT T2		-10		Reference			dB
	GT T3		-40		-0.2	—	0.2	dB
	GT T4		-50		-0.6	—	0.6	dB
	GT T5		-55		-1.2	—	1.2	dB
Receive Gain Tracking	GT R1	1020	3	—	-0.2	—	0.2	dB
	GT R2		-10		Reference			dB
	GT R3		-40		-0.2	—	0.2	dB
	GT R4		-50		-0.6	—	0.6	dB
	GT R5		-55		-1.2	—	1.2	dB

## AC Characteristics (Continued)

 $(V_{DD} = 2.4 \text{ V to } 3.3 \text{ V, } T_a = -40^\circ\text{C to } +85^\circ\text{C})$ 

Parameter	Symbol	Condition			Min.	Typ.	Max.	Unit
		Freq. (Hz)	Level (dBm0)	Others				
Idle Channel Noise	$N_{IDLT}$	—	AIN = SG	(*1)	—	—	-68	dBm0p
	$N_{IDLR}$	—	—	(*1,*2)	—	—	-72	
Absolute Signal Amplitude	$A_{VT}$	1020	0	GSX	0.285	0.320 (*3)	0.359	Vrms
	$A_{VR}$			VFRO	0.285	0.320 (*3)	0.359	Vrms
Power Supply Noise Rejection Ratio	$P_{SRRT}$	Noise Freq: 0 to 50 kHz	Noise Level: 50 mVpp	—	30	—	—	dB
	$P_{SRRR}$				30	—	—	dB
Digital Input/Output Timing PCM Interface	$t_{SDX}$ $t_{SDR}$	—	1 LSTTL + 100 pF	See Fig. 5	0	—	200	ns
	$t_{XD1}$ $t_{RD1}$				0	—	200	ns
	$t_{XD2}$ $t_{RD2}$				0	—	200	ns
	$t_{XD3}$ $t_{RD3}$				0	—	200	ns
Serial Port Digital Input/Output Setting Time	$t_{M1}$	—	CL = 50 pF	See Fig. 6	50	—	—	ns
	$t_{M2}$				50	—	—	ns
	$t_{M3}$				50	—	—	ns
	$t_{M4}$				50	—	—	ns
	$t_{M5}$				100	—	—	ns
	$t_{M6}$				40	—	—	ns
	$t_{M7}$				40	—	—	ns
	$t_{M8}$				0	—	50	ns
	$t_{M9}$				20	—	—	ns
	$t_{M10}$				20	—	—	ns
	$t_{M11}$				0	—	50	ns
Shift Clock Frequency	$f_{EXCK}$	—	—	EXCK	—	—	10	MHz

\*1 Use the P-message weighted filter.

\*2 PCMIN input code "11010101"(A-law)  
"11111111"( $\mu$ -law)

\*3 0.320 Vrms = 0 dBm0 = -7.7 dBm

**AC Characteristics (DTMF and Other Tones)** $(V_{DD} = 2.4 \text{ V to } 3.3 \text{ V, } T_a = -40^\circ\text{C to } +85^\circ\text{C})$ 

Parameter	Symbol	Condition		Min.	Typ.	Max.	Unit
Frequency Difference	$D_{FT}$	DTMF Tones, Other Tones		-1.5	—	+1.5	%
Original (Reference) Tones Signal Level *4	$V_{TL}$	Transmit Tones	DTMF (Low)	-18	-16	-14	dBm0
	$V_{TH}$	(Gain setting 0 dB)	DTMF (High) and Other Tones	-16	-14	-12	dBm0
	$V_{RL}$	Receive Tones	DTMF (Low)	-10	-8	-6	dBm0
	$V_{RH}$	(Gain setting -6 dB)	DTMF (High) and Other Tones	-8	-6	-4	dBm0
Relative Level of DTMF Tones	$R_{DTMF}$	$V_{TH}/V_{TL}, V_{RH}/V_{RL}$		+1	+2	+3	dB

\*4 Does not include the setting value for the programmable gain.

**AC Characteristics (Programmable Gain Stages)** $(V_{DD} = 2.4 \text{ V to } 3.3 \text{ V, } T_a = -40^\circ\text{C to } +85^\circ\text{C})$ 

Parameter	Symbol	Condition	Min.	Typ.	Max.	Unit
Gain Accuracy	$D_G$	All gain stages, to programmed value	-1	0	+1	dB

**AC Characteristics (Voice Detect Function)** $(V_{DD} = 2.4 \text{ V to } 3.3 \text{ V, } T_a = -40^\circ\text{C to } +85^\circ\text{C})$ 

Parameter	Symbol	Condition	Min.	Typ.	Max.	Unit
Voice Detection Time	TVON	Silence>Voice	—	5	—	ms
	TVOF	(Voice/Silence differential: 10 dB)	140	160	180	ms
Voice Detection Accuracy	DVX	For detection level set values by CR6-B6, B5	-2.5	0	2.5	dB

**TIMING DIAGRAM**

Transmit Side PCM Timing (Normal Synchronous Interface)

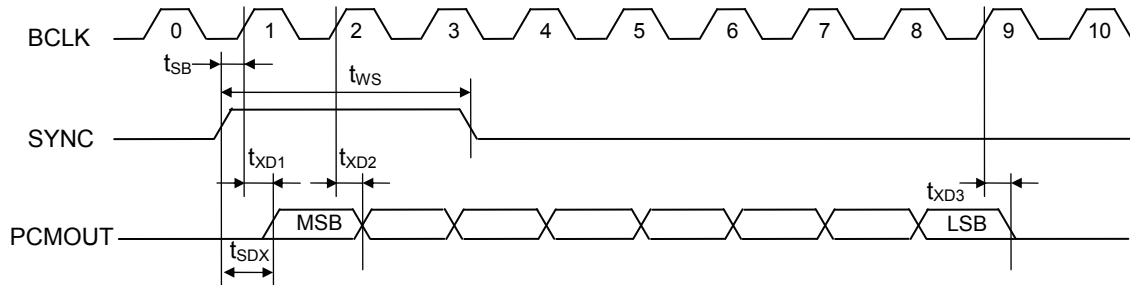

When  $t_{SB} \geq 0$ , the Delay of the MSB is defined as  $t_{XD1}$ .  
 When  $t_{SB} < 0$ , the Delay of the MSB is defined as  $t_{SDX}$ .

Transmit Side PCM Timing (Short Frame Synchronous Interface)

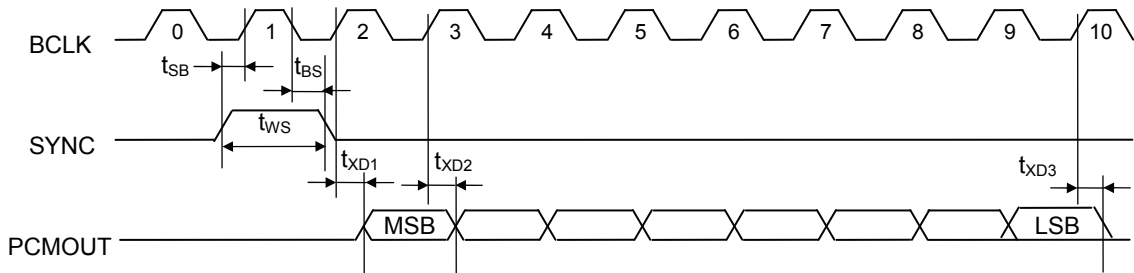

Receive Side PCM Timing (Normal Synchronous Interface)

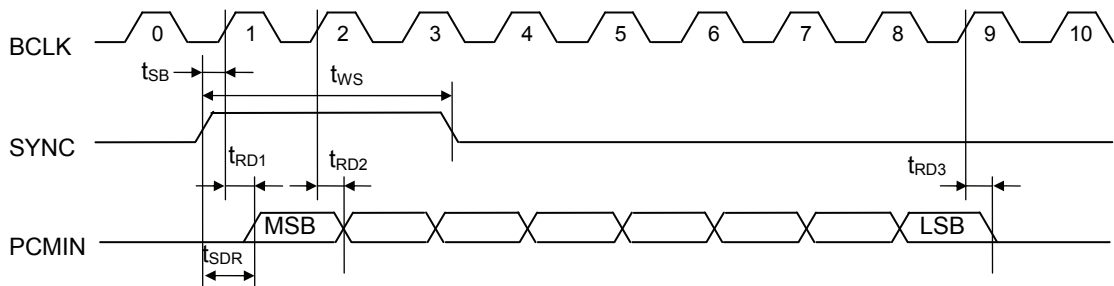

Receive Side PCM Timing (Short Frame Synchronous Interface)

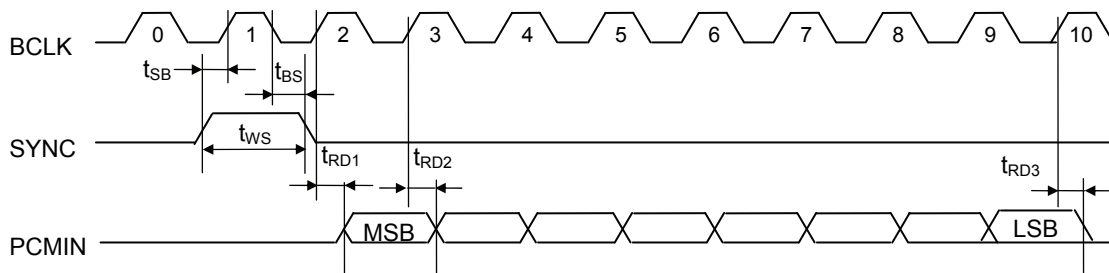

**Figure 4 PCM Interface Timing**

Serial Port Timing for Microcontroller Interface

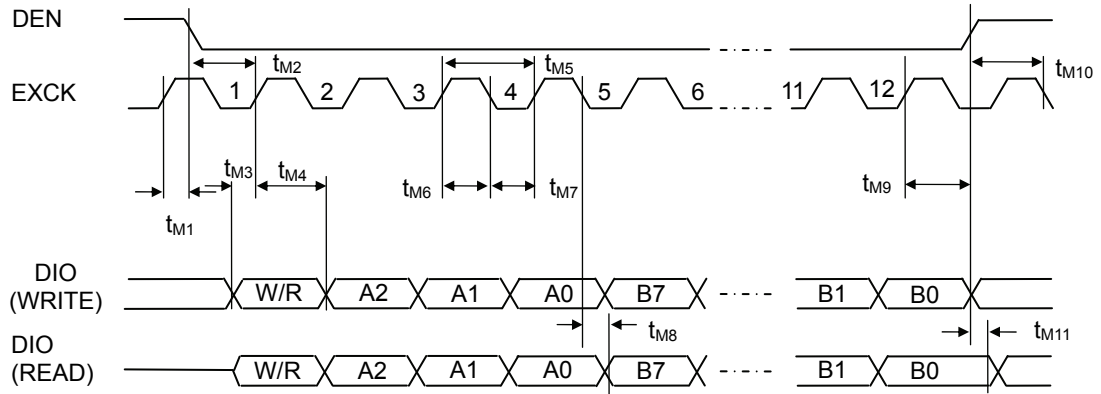

Figure 5 Serial Control Port Interface

## FUNCTIONAL DESCRIPTION

### Control Registers

CR0 (Basic operating mode 1)

Note: Initial Value: Reset state by  $\overline{\text{PDN}}$

	B7	B6	B5	B4	B3	B2	B1	B0
CR0	A/ $\mu$ SEL	PON AOUT	PDN ALL	PDN TX	PDN RX	SLP	SLP SEL	LNR
Initial Value	0	0	0	0	0	0	0	0

- B7..... PCM companding law select; 0/ $\mu$ -law, 1/A-law
- B6..... Power on control for output amps (AOUT+, AOUT-); 0/Power down, 1/Power on
- B5..... Power down (entire system); 0/Power on, 1/Power down  
When using this data for power down control, set pin  $\overline{\text{PDN}}$  at "1" level.  
The control registers are not reset by this signal.
- B4..... Power down (transmit and amplifier A); 0/Power on, 1/Power down
- B3..... Power down (receive only); 0/Power on, 1/Power down
- B2..... Slope filter enable; 0/Slope filter disable, 1/ Slope filter enable
- B1..... The type of slope filter select; 0/CASE1, 1/CASE2, refer to Figure 6.
- B0..... PCM interface linear code select;  
0/Companding law selected by CR0-B7  
1/14-bit linear code (2's complement) in spite of CR0-B7

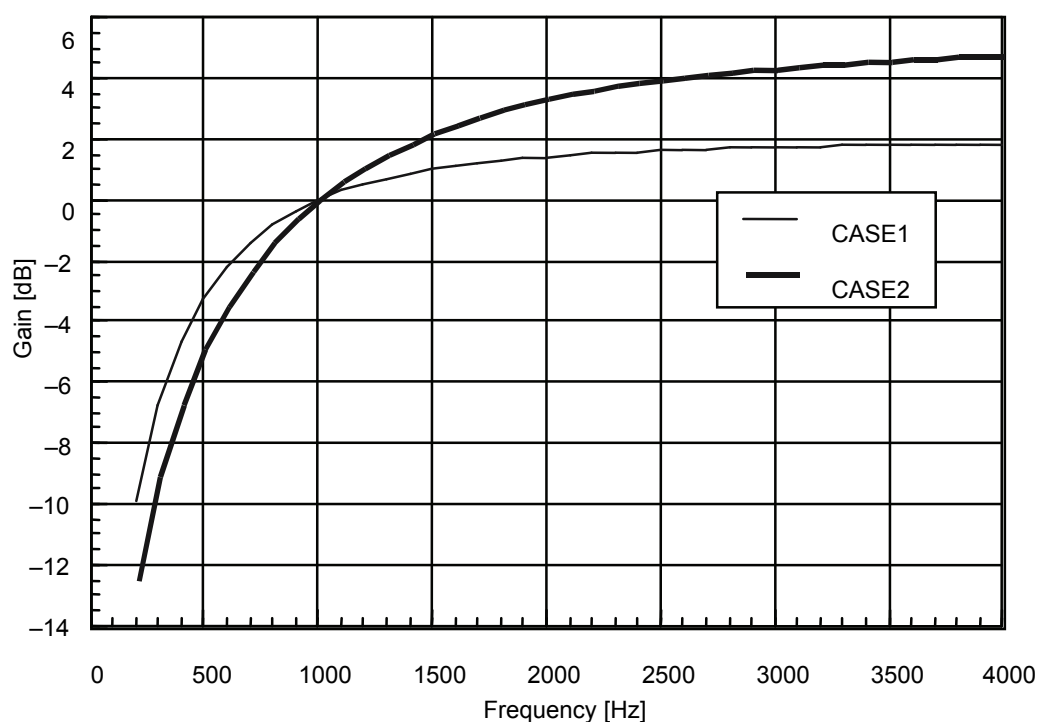

Figure 6 Frequency Response of Slope Filter

CR1 (Basic operating mode 2)

	B7	B6	B5	B4	B3	B2	B1	B0
CR1	—	—	—	—	SHORT FRAME	SW D/E	SW C/A	RX PAD
Initial Value	0	0	0	0	0	0	0	0

B7, B6, B5, B4·····Not used

B3·····Short frame synchronous interface select;

0/Long frame synchronous interface, 1/Short frame synchronous interface

B2·····Analog switch control : 0/SWD to SWE open, 1/ SWD to SWE closed

B1·····Analog switch control : 0/SWB to SWA closed. The SWC pin is high impedance.  
1/SWB to SWC closed. The SWA pin is high impedance.B0·····Receive side PAD : 1/inserted, 12 dB loss  
0/no PAD

CR2 (PCM CODEC operating mode setting and transmit/receive gain adjustment)

	B7	B6	B5	B4	B3	B2	B1	B0
CR2	TX ON/OFF	TX GAIN2	TX GAIN1	TX GAIN0	RX ON/OFF	RX GAIN2	RX GAIN1	RX GAIN0
Initial Value	0	0	1	1	0	0	1	1

B7..... PCM coder disable; 0/Enable, 1/Disable (transmit PCM idle pattern)

B6, B5, B4..... Transmit gain adjustment, refer to Table 2.

B3..... PCM decoder disable; 0/Enable, 1/Disable (receive PCM idle pattern)

B2, B1, B0..... Receive gain adjustment, refer to Table 2.

Table 2

B6	B5	B4	Transmit Gain	B2	B1	B0	Receive Gain
0	0	0	-6 dB	0	0	0	-12 dB
0	0	1	-4 dB	0	0	1	-9 dB
0	1	0	-2 dB	0	1	0	-6 dB
0	1	1	0 dB	0	1	1	-3 dB
1	0	0	+2 dB	1	0	0	0 dB
1	0	1	+4 dB	1	0	1	+3 dB
1	1	0	+6 dB	1	1	0	+6 dB
1	1	1	+8 dB	1	1	1	+9 dB

The above gain settings table shows the transmit/receive voice signal gain settings and the transmit side gain settings for DTMF tones and other tones. Tone signal transmission is enabled by CR4-B6, and the gain setting is set to the levels shown below.

DTMF tones (low group): -16 dBm0

DTMF tones (high group) and other tones: -14 dBm0

For example, if the transmit gain set value is set to +8 dB (B6, B5, B4) = (1, 1, 1), then the following tones appear at the PCMOOUT pin.

DTMF tones (low group): -8 dBm0

DTMF tones (high group) and other tones: -6 dBm0

Gain setting for the side tone (path to the receive side from the transmit side) and the receive side tone is provided by register CR3.

CR3 (Side tone and other tone generator gain setting)

	B7	B6	B5	B4	B3	B2	B1	B0
CR3	Side Tone GAIN2	Side Tone GAIN1	Side Tone GAIN0	TONE ON/OFF	TONE GAIN3	TONE GAIN2	TONE GAIN1	TONE GAIN0
Initial Value	0	0	0	0	0	0	0	0

B7, B6, B5…………Side tone path gain setting, refer to Table 3.

B4………… Tone generator enable; 0/Disable, 1/Enable

B3, B2, B1, B0…… Tone generator gain adjustment for receive side, refer to Table 4.

Table 3

B7	B6	B5	Side Tone Path Gain
0	0	0	OFF
0	0	1	-15 dB
0	1	0	-13 dB
0	1	1	-11 dB
1	0	0	-9 dB
1	0	1	-7 dB
1	1	0	-5 dB
1	1	1	-3 dB

Table 4

B3	B2	B1	B0	Tone Generator Gain	B3	B2	B1	B0	Tone Generator Gain
0	0	0	0	OFF	1	0	0	0	-20 dB
0	0	0	1	-34 dB	1	0	0	1	-18 dB
0	0	1	0	-32 dB	1	0	1	0	-16 dB
0	0	1	1	-30 dB	1	0	1	1	-14 dB
0	1	0	0	-28 dB	1	1	0	0	-12 dB
0	1	0	1	-26 dB	1	1	0	1	-10 dB
0	1	1	0	-24 dB	1	1	1	0	-8 dB
0	1	1	1	-22 dB	1	1	1	1	-6 dB

The tone generator gain setting table for the receive side, as shown in Table 4, depends upon the following reference levels.

DTMF tones (low group): -2 dBm0  
 DTMF tones (high group) and other tones: 0 dBm0

For example, when selecting -6 dB (B3, B2, B1, B0) = (1, 1, 1, 1) as a tone generator gain, the signal amplitude of each DTMF tone on SAO or VFRO is as follows:

DTMF tones (low group): -8 dBm0  
 DTMF tones (high group) and other tones: -6 dBm0

CR4 (Tone generator operating mode and frequency select)

	B7	B6	B5	B4	B3	B2	B1	B0
CR4	DTMF/ Others SEL	TONE SEND	SAO/ VFRO	TONE4	TONE3	TONE2	TONE1	TONE0
Initial Value	0	0	0	0	0	0	0	0

B7 ..... DTMF or other tones select; 0/Others, 1/DTMF

B6 ..... Tone transmit enable (transmit side); 0/Voice signal (transmit), 1/Tone transmit

B5 ..... Tone output pin select (receive side); 0/VFRO, 1/SAO

B4, B3, B2, B1, B0 ... Tone frequency setting, refer to Tables 5-1 and 5-2.

(a) B7 = 1 (DTMF tones)

Table 5-1

B4	B3	B2	B1	B0	Frequency	B4	B3	B2	B1	B0	Frequency
*	0	0	0	0	697 Hz + 1209 Hz	*	1	0	0	0	852 Hz + 1209 Hz
*	0	0	0	1	697 Hz + 1336 Hz	*	1	0	0	1	852 Hz + 1336 Hz
*	0	0	1	0	697 Hz + 1477 Hz	*	1	0	1	0	852 Hz + 1477 Hz
*	0	0	1	1	697 Hz + 1633 Hz	*	1	0	1	1	852 Hz + 1633 Hz
*	0	1	0	0	770 Hz + 1209 Hz	*	1	1	0	0	941 Hz + 1209 Hz
*	0	1	0	1	770 Hz + 1336 Hz	*	1	1	0	1	941 Hz + 1336 Hz
*	0	1	1	0	770 Hz + 1477 Hz	*	1	1	1	0	941 Hz + 1477 Hz
*	0	1	1	1	770 Hz + 1633 Hz	*	1	1	1	1	941 Hz + 1633 Hz

\*Undefined

(b) B7 = 0 (Other tones)

Table 5-2

B4	B3	B2	B1	B0	Frequency	B4	B3	B2	B1	B0	Frequency
0	0	0	0	0	2730 Hz/2500 Hz 8 Hz wamble	1	0	0	0	0	1200 Hz
0	0	0	0	1	2000 Hz/2667 Hz 8 Hz wamble	1	0	0	0	1	1300 Hz
0	0	0	1	0	1000 Hz/1333 Hz 8 Hz wamble	1	0	0	1	0	—
0	0	0	1	1	—	1	0	0	1	1	1477 Hz
0	0	1	0	0	—	1	0	1	0	0	1633 Hz
0	0	1	0	1	—	1	0	1	0	1	2000 Hz
0	0	1	1	0	—	1	0	1	1	0	2100 Hz
0	0	1	1	1	—	1	0	1	1	1	—
0	1	0	0	0	—	1	1	0	0	0	2400 Hz
0	1	0	0	1	400 Hz	1	1	0	0	1	—
0	1	0	1	0	440 Hz	1	1	0	1	0	2500 Hz
0	1	0	1	1	480 Hz	1	1	0	1	1	—
0	1	1	0	0	—	1	1	1	0	0	—
0	1	1	0	1	667 Hz	1	1	1	0	1	2700 Hz
0	1	1	1	0	800 Hz	1	1	1	1	0	—
0	1	1	1	1	1000 Hz	1	1	1	1	1	3000 Hz

CR5 (Not used)

	B7	B6	B5	B4	B3	B2	B1	B0
CR5	—	—	—	—	—	—	—	—
Initial Value	0	0	0	0	0	0	0	0

B7-B0…………… Not used

CR6 (VOX function control)

	B7	B6	B5	B4	B3	B2	B1	B0
CR6	VOX ON/OFF	ON LVL1	ON LVL0	—	—	—	—	—
Initial Value	0	0	0	0	0	0	0	0

B7…………… VOX function enable; 0/Disable, 1/Enable

If B7 is set to a logic “1”, B3 should be set to a logic “1”.

B6, B5…………… Voice detector level setting;

(0,0): -20 dBm0 (0,1): -26 dBm0 (1,0): -32 dBm0 (1,1): -38 dBm0

B4, B2, B1, B0…………… Not used

CR7 (Detect register, read only)

	B7	B6	B5	B4	B3	B2	B1	B0
CR7	VOX OUT	TX NOISE LVL1	TX NOISE LVL0	—	—	—	—	—
Initial Value	0	0	0	*	*	*	*	*

\*For IC testing

B7…………… Voice detection; 0/Silence, 1/Voice detect

B6, B5…………… Voice detect level (indicator);

(0,0): Below -50 dBm0

(0,1): -40 to -50 dBm0

(1,0): -30 to -40 dBm0

(1,1): Above -30 dBm0

Note: These outputs are enabled when the VOX function is turned on by CR6-B7.

B4, B3, B2, B1, B0…………… Not used

APPLICATION CIRCUIT

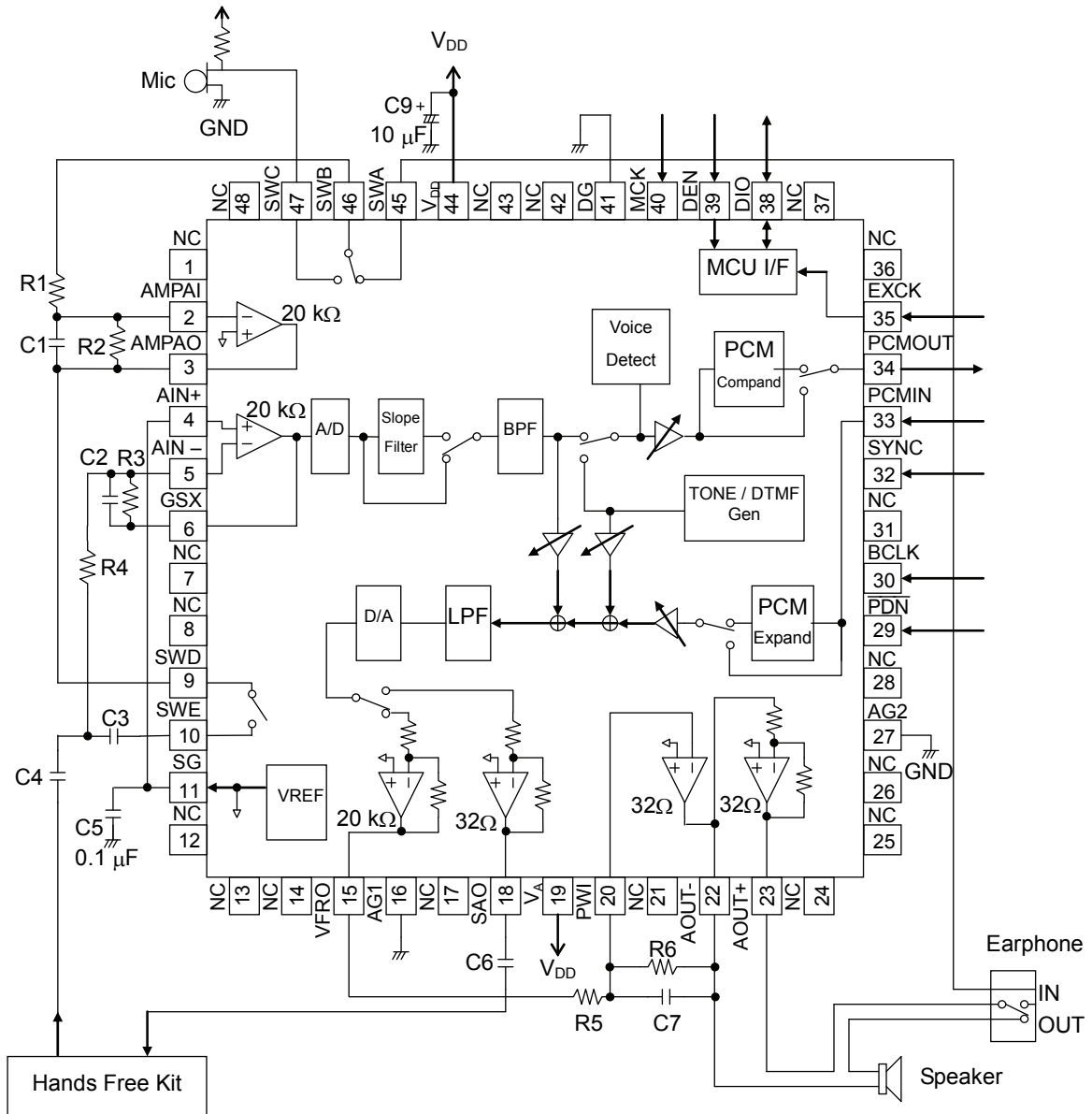

PACKAGE DIMENSIONS

(Unit: mm)

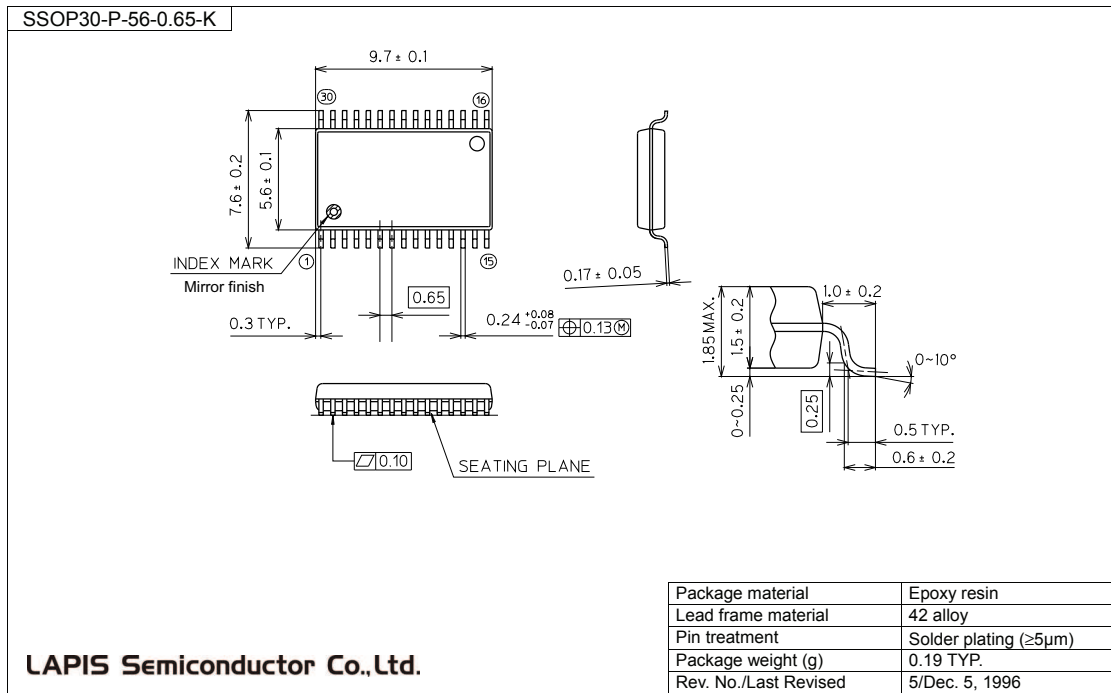

Notes for Mounting the Surface Mount Type Package

The surface mount type packages are very susceptible to heat in reflow mounting and humidity absorbed in storage. Therefore, before you perform reflow mounting, contact ROHM's responsible sales person for the product name, package name, pin number, package code and desired mounting conditions (reflow method, temperature and times).

(Unit: mm)

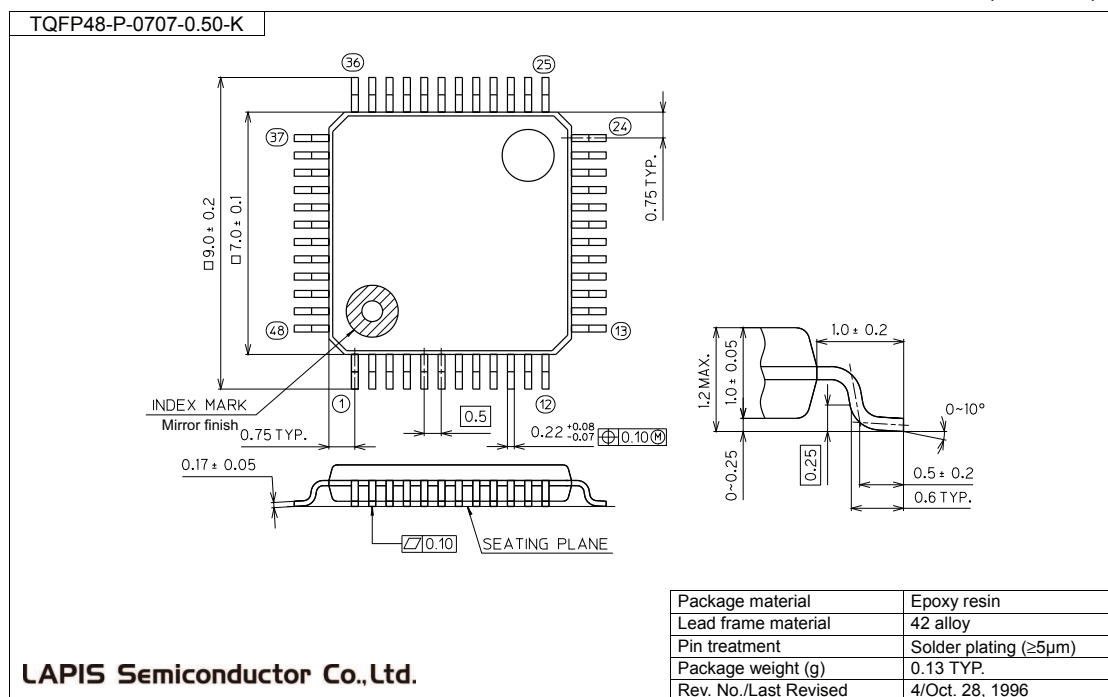

### Notes for Mounting the Surface Mount Type Package

The surface mount type packages are very susceptible to heat in reflow mounting and humidity absorbed in storage. Therefore, before you perform reflow mounting, contact ROHM's responsible sales person for the product name, package name, pin number, package code and desired mounting conditions (reflow method, temperature and times).

(Unit: mm)

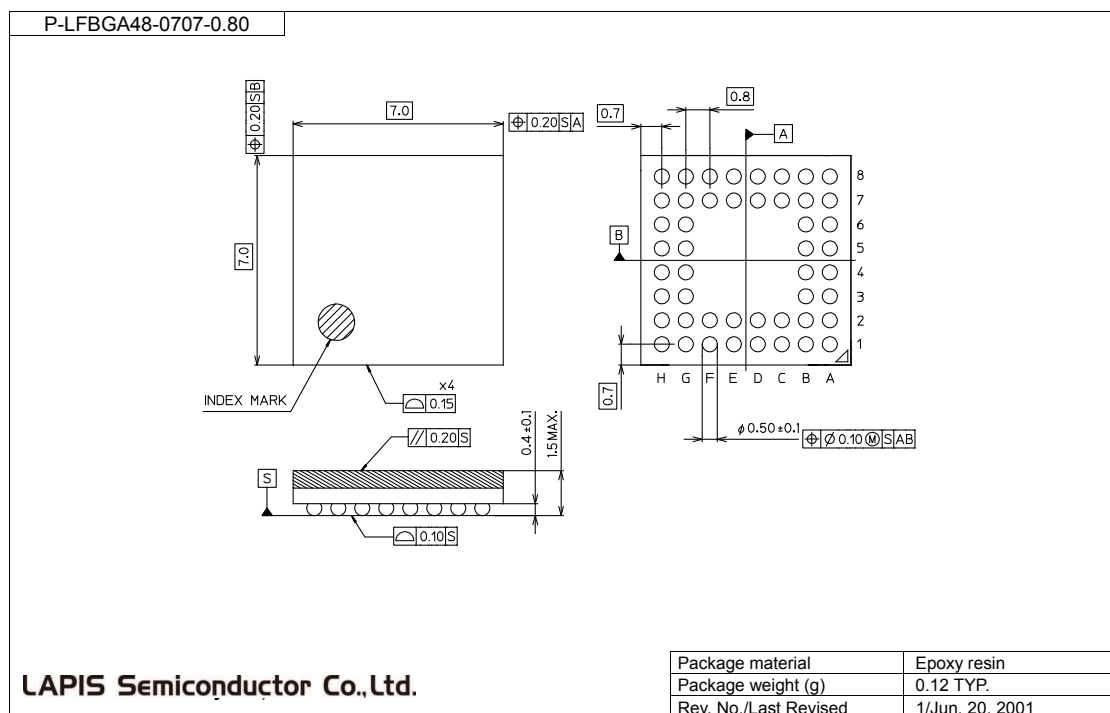

Notes for Mounting the Surface Mount Type Package

The surface mount type packages are very susceptible to heat in reflow mounting and humidity absorbed in storage. Therefore, before you perform reflow mounting, contact ROHM's responsible sales person for the product name, package name, pin number, package code and desired mounting conditions (reflow method, temperature and times).

**REVISION HISTORY**

Document No.	Date	Page		Description
		Previous Edition	Current Edition	
FEDL7732A-01-01	Jun. 8, 2007	—	—	Final edition 1

NOTICE

No copying or reproduction of this document, in part or in whole, is permitted without the consent of LAPIS Semiconductor Co., Ltd.

The content specified herein is subject to change for improvement without notice.

The content specified herein is for the purpose of introducing LAPIS Semiconductor's products (hereinafter "Products"). If you wish to use any such Product, please be sure to refer to the specifications, which can be obtained from LAPIS Semiconductor upon request.

Examples of application circuits, circuit constants and any other information contained herein illustrate the standard usage and operations of the Products. The peripheral conditions must be taken into account when designing circuits for mass production.

Great care was taken in ensuring the accuracy of the information specified in this document. However, should you incur any damage arising from any inaccuracy or misprint of such information, LAPIS Semiconductor shall bear no responsibility for such damage.

The technical information specified herein is intended only to show the typical functions of and examples of application circuits for the Products. LAPIS Semiconductor does not grant you, explicitly or implicitly, any license to use or exercise intellectual property or other rights held by LAPIS Semiconductor and other parties. LAPIS Semiconductor shall bear no responsibility whatsoever for any dispute arising from the use of such technical information.

The Products specified in this document are intended to be used with general-use electronic equipment or devices (such as audio visual equipment, office-automation equipment, communication devices, electronic appliances and amusement devices).

The Products specified in this document are not designed to be radiation tolerant.

While LAPIS Semiconductor always makes efforts to enhance the quality and reliability of its Products, a Product may fail or malfunction for a variety of reasons.

Please be sure to implement in your equipment using the Products safety measures to guard against the possibility of physical injury, fire or any other damage caused in the event of the failure of any Product, such as derating, redundancy, fire control and fail-safe designs. LAPIS Semiconductor shall bear no responsibility whatsoever for your use of any Product outside of the prescribed scope or not in accordance with the instruction manual.

The Products are not designed or manufactured to be used with any equipment, device or system which requires an extremely high level of reliability the failure or malfunction of which may result in a direct threat to human life or create a risk of human injury (such as a medical instrument, transportation equipment, aerospace machinery, nuclear-reactor controller, fuel-controller or other safety device). LAPIS Semiconductor shall bear no responsibility in any way for use of any of the Products for the above special purposes. If a Product is intended to be used for any such special purpose, please contact a ROHM sales representative before purchasing.

If you intend to export or ship overseas any Product or technology specified herein that may be controlled under the Foreign Exchange and the Foreign Trade Law, you will be required to obtain a license or permit under the Law.