ML7020

1200 bps MODEM for Remote Control Systems

GENERAL DESCRIPTION

The ML7020 is a 1200 bps modem LSI developed for remote control systems. The functions incorporated are those of a 1200 bps FSK modem conforming to ITU-T Recommendations V.23, DTMF signal generation and detection, call progress tone (CPT) generation and detection. Each functional block can be controlled via a 4-bit processor interface.

FEATURES

- Single 5 V power supply operation (V_{DD} : 4.5 to 5.5 V)
- Low power consumption: During operation: 5 mA typ.
During the power down mode: 7 μ A typ.
- Built-in 1200 bps modem conforming to ITU-T V.23 recommendations
- Built-in DTMF signal generator with a switchable 6-dB attenuator
- Built-in DTMF detector (the input can be selected from either the line or the terminal)
- Built-in call progress tone generator. The output frequency can be selected from 400 Hz and 800 Hz.
- Built-in call progress tone detector
- Three analog input systems (switchable)
- Analog output for the line is of the differential type and can drive a 600 Ω line transformer.
- Analog output for the terminal is of the single-ended type and can drive a 1.2 k Ω load.
- Built-in switch for selecting the 600 Ω termination
- 4-Bit processor interface
- Built-in oscillator circuit for a 3.579545 MHz crystal
- Package: 32-Pin plastic SSOP (SSOP32-P-430-1.00-K) (Product name: ML7020MB)

BLOCK DIAGRAM

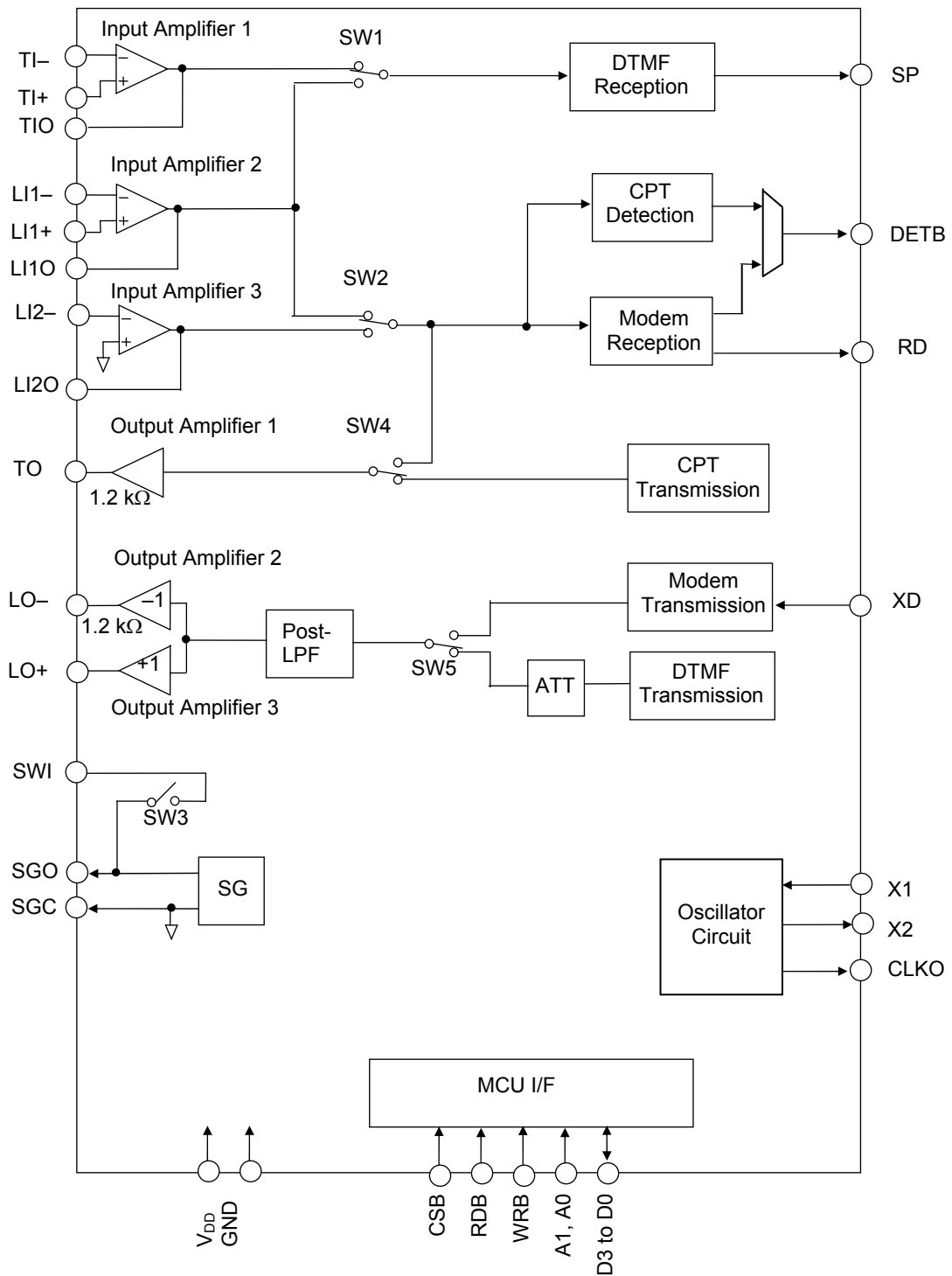

* CPT: Call progress tone

* The state shown of each switch is that when the register is set to "0".

PIN CONFIGURATION (TOP VIEW)

32-Pin plastic SSOP

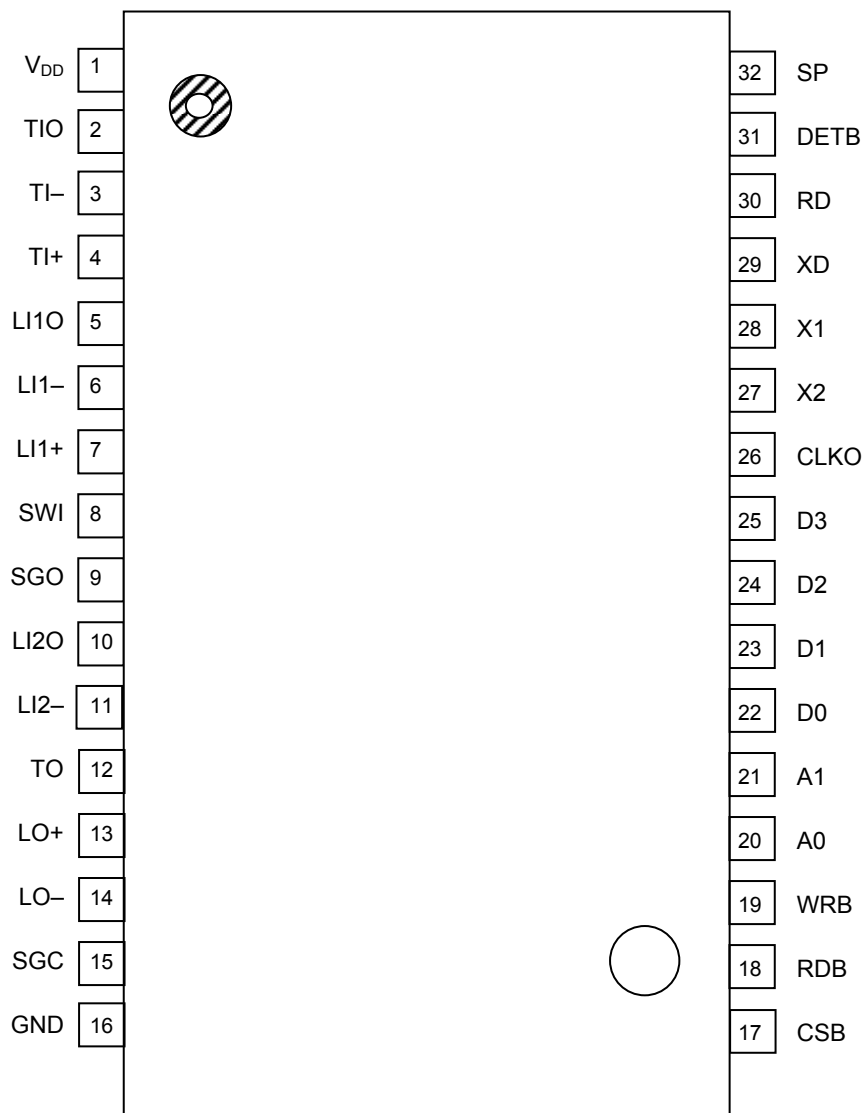

PIN DESCRIPTIONS

Pin No.	Symbol	I/O	Description
1	V _{DD}		Power supply pin. Connect a +5 V power supply to this pin.
2	TIO	O	The output pin of the input amplifier 1. See Figure 1. For the sake of noise reduction, connect a capacitor between this pin and TI- (3) so as to attenuate high frequency components above 10 kHz.
3	TI-	I	The inverting input pin for the input amplifier 1. When the input amplifier 1 is not used, connect pin TIO (2) to pin TI- (3), and connect pin TI+ (4) to pin SGO.
4	TI+	I	The non-inverting input pin for the input amplifier 1.
5	LI1O	O	The output pin for the input amplifier 2. See Figure 1. For the sake of noise reduction, connect a capacitor between this pin and LI1- (6) so as to attenuate high frequency components above 10 kHz.
6	LI1-	I	The inverting input pin for the input amplifier 2. When the input amplifier 2 is not used, connect pin LI1O (5) and LI1- (6), and connect pin LI+ (7) to pin SGO.
7	LI1+	I	The non-inverting input pin for the input amplifier 2.
8	SWI	I	The input pin for SW3. This pin is connected internally to SGO (9) when SW3 is to be made ON.
9	SGO	O	The signal ground output pin for external circuits. A voltage of about V _{DD} /2 is output from this pin.
10	LI2O	O	The output pin for the input amplifier 3. See Figure 1. For the sake of noise reduction, connect a capacitor between this pin and LI2- (10) so as to attenuate high frequency components above 10 kHz.
11	LI2-	I	The inverting input pin for the input amplifier 3. When the input amplifier 3 is not used, connect pin LI2O (10) and LI2- (11).
12	TO	O	The output pin of the output amplifier 1. Can drive a load of 1.2 kΩ or more.
13	LO+	O	The non-inverting output pin for the output amplifier 2. See Figure 2 for details of connecting a peripheral circuit.
14	LO-	O	The inverting output pin of the output amplifier 2. See Figure 2 for details of connecting a peripheral circuit.
15	SGC	O	The signal ground output pin for internal circuits. A voltage of about V _{DD} /2 is output from this pin. Connect a 1 μF capacitor between SGC (15) and GND (16).
16	GND		The ground pin for the LSI. Connect a 0 V input to this pin.
17	CSB	I	The chip select pin for the processor interface. Reading and writing are possible when this input is "0". Reading and writing are disabled when this input is "1".
18	RDB	I	The read control pin for the processor interface. Data can be read from the LSI when this pin is "0".
19	WRB	I	The write control pin for the processor interface. Data is written into this LSI at the rising edge of the WR signal.
20	A0	I	The address input pin A0 for the processor interface.

Pin No.	Symbol	I/O	Description
21	A1	I	The address input pin A1 for the processor interface.
22	D0	IO	The data input/output pin D0 for the processor interface.
23	D1	IO	The data input/output pin D1 for the processor interface.
24	D2	IO	The data input/output pin D2 for the processor interface.
25	D3	IO	The data input/output pin D3 for the processor interface.
26	CLKOUT	O	The 3.579545 MHz oscillator circuit output pin.
27	X2	O	The pins for connecting a 3.579545 MHz crystal. The capacitors and the feedback resistor are internally connected to these pins. When inputting an external clock, connect the input to the X1 pin via a 1000 pF capacitor and leave the pin X2 open.
28	X1	I	
29	XD	I	The modem transmit data input pin. The "1" level corresponds to the mark data and the "0" level corresponds to the space data.
30	RD	O	The modem receive data output pin. The mark and space data are the same as for XD. A mark is output when no carrier is detected.
31	DETB	O	The pin for outputting the carrier detect signal of the modem or the call progress tone detector output. The detection result corresponding to the respective operating mode is output from this pin. A "0" indicates detection and a "1" indicates non-detection.
32	SP	O	The DTMF reception detection output pin. A "0" indicates detection and a "1" indicates non-detection.

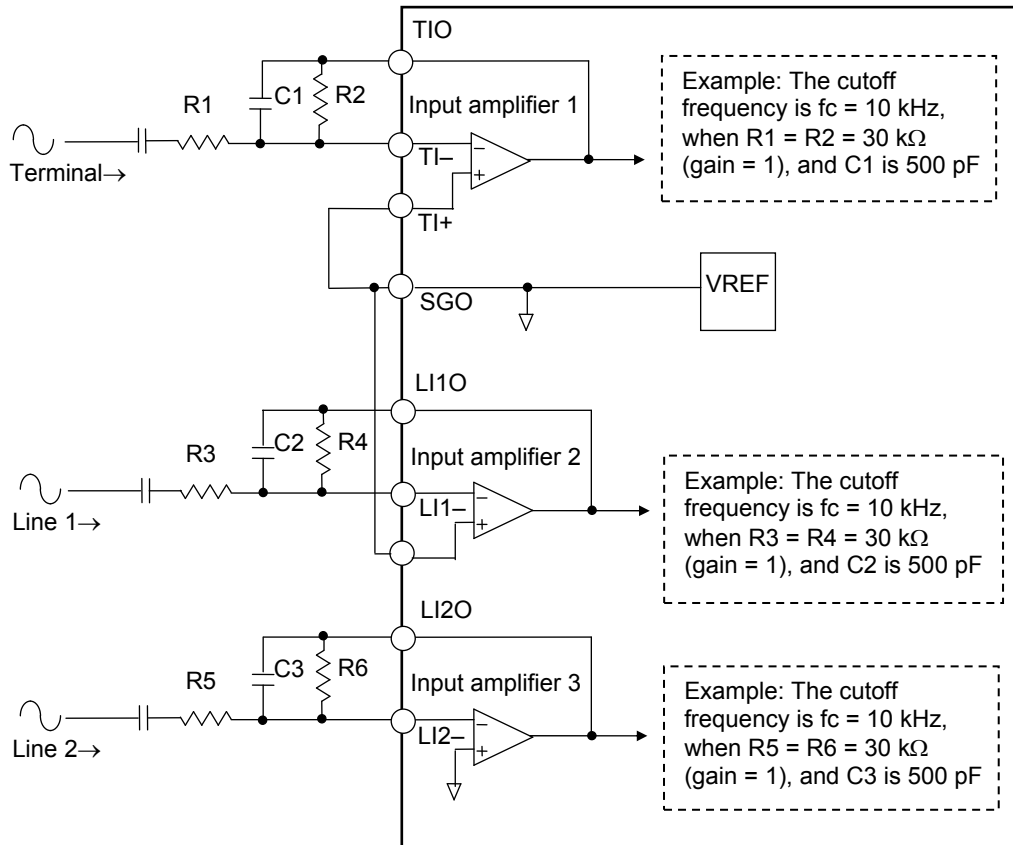

Figure 1 Input amplifier 1 to 3 interface

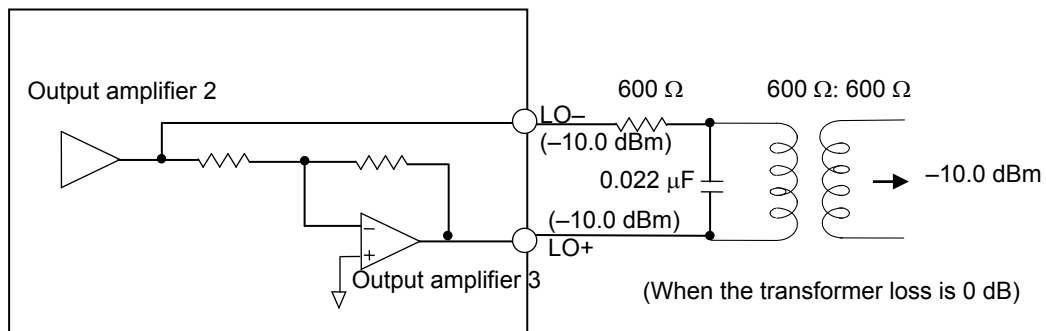

Figure 2 Output amplifier 2, 3 interface example

ABSOLUTE MAXIMUM RATINGS

Parameter	Symbol	Condition	Rating	Unit
Power supply voltage	V_{DD}	—	-0.3 to +7.0	V
Permissible power dissipation	P_D	—	to 130	mW
Output short circuit current	I_{SHT}	Shorted to V_{DD} or ground.	to 60	mA
Analog input voltage	V_{AIN}	—	-0.3 to $V_{DD}+0.3$	V
Digital input voltage	V_{DIN}	—	-0.3 to $V_{DD}+0.3$	V
Storage temperature range	T_{stg}	—	-55 to +150	°C

RECOMMENDED OPERATING CONDITIONS $(V_{DD} = 4.5 \text{ to } 5.5 \text{ V}, T_a = -40 \text{ to } +85^\circ\text{C})$

Parameter	Symbol	Condition	Min.	Typ.	Max.	Unit	
Power supply voltage	V_{DD}	—	4.5	5.0	5.5	V	
Operating temperature range	T_a	—	-40	—	+85	°C	
High level input voltage	V_{IH}	Digital input pins	0.8 $\times V_{DD}$	—	V_{DD}	V	
Low level input voltage	V_{IL}	Digital input pins	0	—	0.2 $\times V_{DD}$	V	
Digital input rise time	t_{ir}	Digital input pins	—	—	50	ns	
Digital input fall time	t_{if}	Digital input pins	—	—	50	ns	
Digital output load	C_{DL}	Digital output pins	—	—	100	pF	
Bypass capacitor for SGC	C_{SG}	Between SGC and GND	1	—	—	μF	
Bypass capacitor for V_{DD}	C_{VG}	Between V_{DD} and ground	10	—	—	μF	
Crystal	Oscillating frequency	—	—	3.579545	—	MHz	
	Frequency deviation	—	25 \pm 5°C	-100	—	+100	ppm
	Temperature characteristics	—	In the temperature range -40 to +85°C	-50	—	+50	ppm
	Equivalent series resistor	—	—	—	—	90	Ω
	Production load capacitance	—	—	—	16	—	pF
Input clock frequency deviation	f_{CLK}	Values when an X1 external clock is input	-0.1	—	+0.1	%	
Input clock duty ratio	DUTY		40	—	60	%	

ELECTRICAL CHARACTERISTICS

DC Characteristics

(V_{DD} = 4.5 to 5.5 V, Ta = -40 to +85°C)

Parameter	Symbol	Condition	Min.	Typ.	Max.	Unit
Power supply current	I _{DD1}	During operation (modem transmission/reception mode)*1	0	5.0	10.0	mA
	I _{DD2}	During operation (tone 1 mode)*1	0	5.0	10.0	mA
	I _{DD3}	During operation (tone 2, tone 3 modes)*1	0	6.0	11.0	mA
	I _{DD4}	During power down	0	7.0	100	μA
Input leak current	I _{IH}	V _I = V _{DD}	—	—	2.0	μA
	I _{IL}	V _I = 0 V	—	—	0.5	μA
High level output voltage	V _{OH}	I _{OH} = -100 μA	V _{DD} -0.1	—	V _{DD}	V
Low level output voltage	V _{OL}	I _{OL} = 100 μA	0	0.05	0.1	V
Input capacitance	C _{IN}	—	—	5	—	pF

*1: See Table 3 for details of the modes.

Analog Interface

(V_{DD} = 4.5 to 5.5 V, Ta = -40 to +85°C)

Parameter	Symbol	Condition	Min.	Typ.	Max.	Unit	
Input resistance	R _{IN}	TI-, TI+, LI1-, LI1+, LI2-	10	—	—	MΩ	
Output load resistance	R _{L1}	TIO, LI1O, LI2O	20	—	—	kΩ	
	R _{L2}	TO (Output amplitude 1 V _{pp} or less)	1.2	—	—	kΩ	
	R _{L3}	LO-, LO+ (differential outputs)	1.2	—	—	kΩ	
Output load capacitance	C _L	Analog outputs	—	—	100	pF	
Output impedance	R _{OX1}	TIO, LI1O, LI2O, TO	—	10	—	Ω	
	R _{OX2}	LO-, LO+, SGO	—	10	—	Ω	
Output DC voltage	V _{O1}	TIO, LI1O, LI2O, TO, LO-, LO+, SGC	—	V _{DD} /2	—	V	
	V _{O2}	SGO	V _{DD} /2 -0.1	V _{DD} /2	V _{DD} /2 +0.1	V	
Out-of-band spurious response	V _{S1}	LO-, LO+ (Differential outputs)	4 to 8 kHz	—	-60	-20	dBm
	V _{S2}		8 to 12 kHz	—	-80	-40	dBm
	V _{S3}		12 kHz to (4 kHz each)	—	-80	-60	dBm
SW3 impedance	R _{SW3}	SW3	—	15	30	Ω	
Output current	I _{SGO}	SGO pin (including via SW3)	-0.6	—	0.6	mA	

AC Characteristics (DTMF Section)

(V_{DD} = 4.5 to 5.5 V, Ta = -40 to +85°C)

Parameter	Symbol	Condition	Min.	Typ.	Max.	Unit		
Transmit level	V _{DTTL}	LO-, LO+_Differential *1	Lower group tone	-7.0	-4.5	-3.0	dBm	
	V _{DTTH}		Higher group tone	-5.5	-2.5	-1.0	dBm	
Transmit signal level relative value	V _{DTDF}	(Higher group tone) – (lower group tone)	1	2	3	dB		
Transmit signal frequency deviation	f _{DDT}	Relative to the nominal frequency	-1.5	—	+1.5	%		
Transmit signal distortion rate	THD _{DT}	(Harmonic waves) – (fundamental wave)	—	—	-23	dB		
DTMF detection level	V _{DETD}	For one frequency	-42	—	-6	dBm		
DTMF non-detection level	V _{REJDT}	For one frequency	—	—	-60	dBm		
Detection frequency band	f _{DETD}	Relative to the nominal frequency	—	—	±1.5	%		
Non-detection frequency band	f _{REJDT}	Relative to the nominal frequency	±3.8	—	—	%		
Level difference between two received frequencies	V _{TWIST}	(Higher group tone) – (lower group tone)	-6	—	+6	dB		
Permissible received noise level	L _{OSSR6}	(Noise level) – (tone level) 0.3 to 3.4 kHz	—	-12	—	dB		
Received dial tone elimination ratio	V _{REJCP}	380 to 420 Hz	37	53	—	dB		
Signal repetition period	t _c	During the tone 1, tone 2, and loop back modes. See Figure 3 and Table 3 for details.	120	—	—	ms		
Input signal persistence duration	t _s		Detection	49	—	—	ms	
	t _l		Non-detection	—	—	24	ms	
Signal quiet duration	t _p			30	—	—	ms	
Instantaneous break protection period	t _{ba}		SP = 0	—	—	0.4	ms	
	t _{bb}		SP = 1	—	—	10	ms	
Detection delay time	t _g			24	41	49	ms	
Detection hold time	t _d			24	28	35	ms	
SP delay time	t _{sp}			0.2	0.6	1.0	ms	
Signal repetition period	t _c		During the tone 3 mode.	60	—	—	ms	
Input signal persistence duration	t _s		See Figure 3 and Table 3 for details.	Detection	35	—	—	ms
	t _l			Non-detection	—	—	10	ms
Signal quiet duration	t _p				21	—	—	ms
Instantaneous break protection period	t _{ba}			SP = 0	—	—	0.4	ms
	t _{bb}	SP = 1		—	—	3.0	ms	
Detection delay time	t _g			12	26	37	ms	
Detection hold time	t _d			15	20	27	ms	
SP delay time	t _{sp}			0.2	0.6	1.0	ms	
ATT attenuation	V _{ATT}	Relative to the ATT = "0" reference		-7.5	-6	-4.5	dB	

Note: 0 dBm = 0.775 Vrms

*1: The value will be 6 dB smaller for pin LO+ or pin LO- alone.

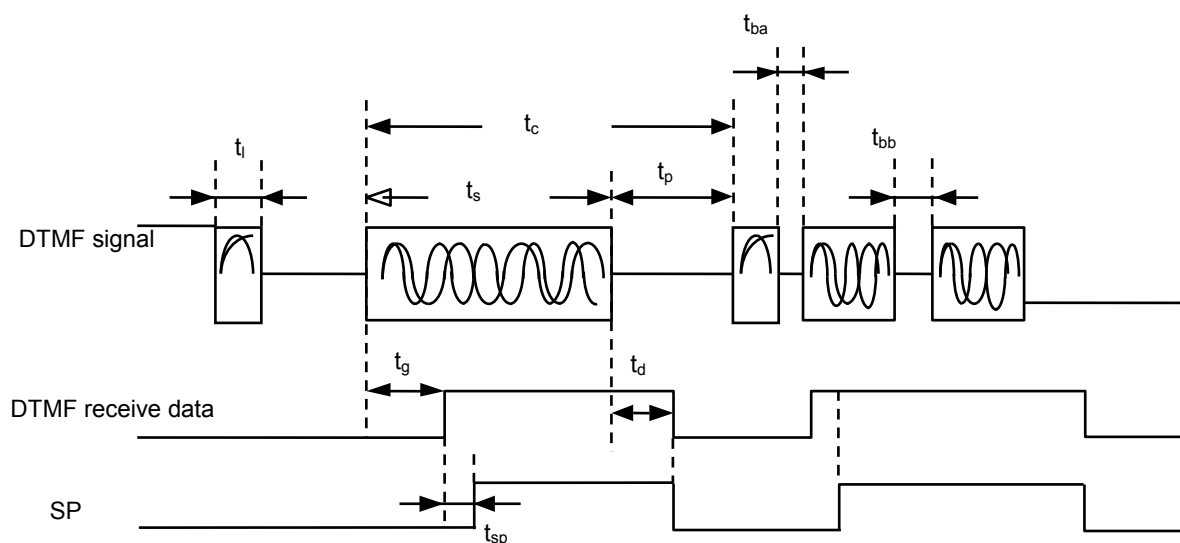

Figure 3 DTMF reception timing

- t_s : Input signal persistence duration (detection)
Normal reception is made when the input signal persistence duration is equal to t_s or more.
- t_i : Input signal persistence duration (non-detection)
The input signal is ignored when the input signal persistence duration is less than t_i , and the SP and DTMF receive data are not output.
- t_p : Signal quiet duration
The DTMF receive data and SP are reset if the input continues to be in the no-signal condition for a duration equal to t_p or longer.
Also, even if the receive data changes during DTMF signal reception, SP continues to be "1" and the DTMF receive data may remain in the initial value and may not change, if the signal quiet duration is less than t_p (including when it changes without any instantaneous break).
- t_{ba} : Instantaneous break protection period 1
This is applicable to the period after the input signal has arrived and until the timing when SP becomes "1". In other words, SP and DTMF receive data are output normally even if a no-signal condition of a duration less than t_{ba} occurs.
- t_{bb} : Instantaneous break protection period 2
This is applicable when SP is "1" (during output of the receive data). In other words, SP and the DTMF receive data are not reset even if a no-signal condition of a duration less than t_{bb} occurs during signal reception.
- t_c : For ensuring normal reception, make sure that the signal repetition period is equal to t_c or more.
- t_g : Detection delay time
The DTMF receive data is output with a delay of t_g relative to the appearance of the input signal.
- t_d : Detection hold time
The output of SP or the DTMF receive data is stopped with a delay of t_d after the termination of the input signal.
- t_{sp} : SP delay time
SP is output after a delay of t_{sp} relative to the output of the DTMF receive data. Therefore, latch the DTMF receive data when the rising edge of SP is detected.

AC Characteristics (Modem Section)

(V_{DD} = 4.5 to 5.5 V, Ta = -40 to +85°C)

Parameter	Symbol	Condition		Min.	Typ.	Max.	Unit
Modem transmit level	V _{AOM}	LO-, LO+ Differential		-6.0	-4.0	-2.0	dBm
Transmit signal level relative value	V _{DM}	(Mark signal) – (space signal)		-1.5	0	+1.5	dB
Transmit carrier frequency	f _M	—	XD = 1	1292	1300	1308	Hz
	f _S	—	XD = 0	2092	2100	2108	Hz
Receive signal level	V _{AI}	Level of LI1O and LI2O		-51	—	-6	dBm
Carrier detection level	V _{ON}	Level of LI1O and LI2O	OFF→ON	—	-44.5	-42	dBm
	V _{OFF}	1700 Hz	ON→OFF	-51	-46.5	—	dBm
Carrier detection hysteresis	V _{HYS}	—			2	—	dB
Carrier detection delay time	t _{CDD}	OFF→-30 dBm		5	10	15	ms
Carrier detection hold time	t _{CDH}	-30 dBm→OFF		23	28	34	ms
Demodulation bias distortion	D _{BS}	1200 bps, 1:1 pattern		-10	—	+10	%

Note: RD is fixed at “1” when the carrier detector is OFF.

AC Characteristics (CLKO)

(V_{DD} = 4.5 to 5.5 V, Ta = -40 to +85°C)

Parameter	Symbol	Condition	Min.	Typ.	Max.	Unit
Output amplitude	V _{COH}	CL = 100 pF	0.9 × V _{DD}	—	V _{DD}	V
	V _{COL}		0	—	0.1 × V _{DD}	V

AC Characteristics (Call Progress Tone Section)

(V_{DD} = 4.5 to 5.5 V, T_a = -40 to +85°C)

Parameter	Symbol	Condition	Min.	Typ.	Max.	Unit	
Transmit level	V _{CPT}	Pin TO	-21.5	-20.0	-18.5	dBm	
Transmit frequency	f _{CPT}	Pin TO	During 400 Hz output	380	400	420	Hz
			During 800 Hz output	780	800	820	Hz
Distortion rate	THD _{CPT}	Pin TO	—	—	-23	dB	
Detection level	V _{DETC}	400 Hz, level of LI1O and LI2O	-46	—	-6	dBm	
Non-detection level	V _{REJCP}	400 Hz, level of LI1O and LI2O	—	—	-60	dBm	
Detection frequency	f _{DETC}	—	360	—	440	Hz	
Non-detection frequency	f _{rejCP}	—	510	—	—	Hz	
			—	—	300	Hz	
Detection persistence period	t _{DETC}	See Figure 4.	Detection	30	—	—	ms
	t _{REJCP}		Non-detection	—	—	10	ms
Detection delay time	t _{DELCP}	See Figure 4.	10	17	30	ms	
Detection hold time	t _{HOLCP}		10	17	30	ms	

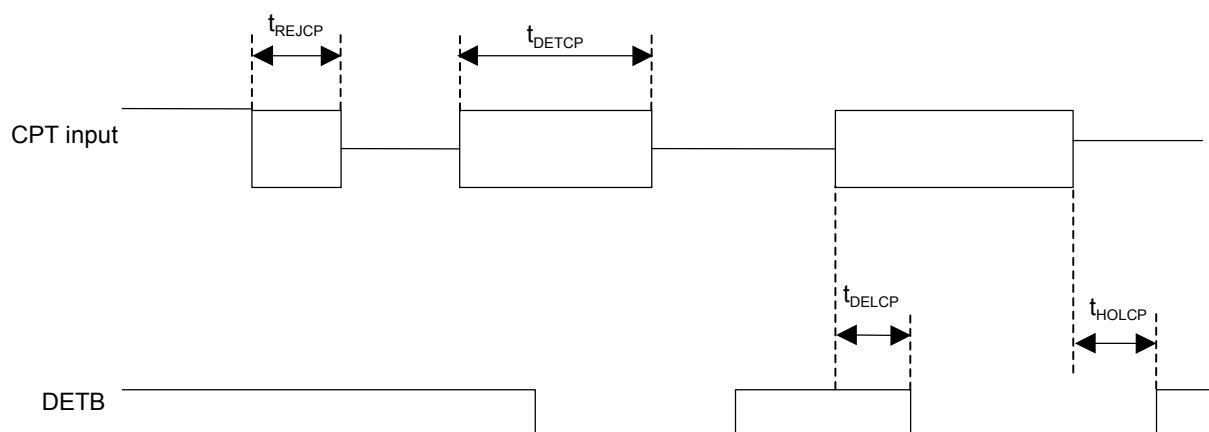

Figure 4 Call progress tone detection timing

AC Characteristics (Processor Interface)

($V_{DD} = 4.5$ to 5.5 V, $T_a = -40$ to $+85^\circ\text{C}$)

Parameter	Symbol	Condition	Min.	Typ.	Max.	Unit
Write signal period	P_W	See Figure 5.	2000	—	—	ns
Write signal width	T_W		100	—	—	ns
Read signal width	T_R		200	—	—	ns
Address data setup time	T_{AW1}		10	—	—	ns
	T_{AR1}		80	—	—	ns
Address data hold time	T_{AW2}		50	—	—	ns
	T_{AR2}		10	—	—	ns
Chip select setup time	T_{CW1}		10	—	—	ns
	T_{CR1}		80	—	—	ns
Chip select hold time	T_{CW2}		50	—	—	ns
	T_{CR2}		10	—	—	ns
Data setup time	T_{DW1}		110	—	—	ns
Data hold time	T_{DW2}		20	—	—	ns
Data output delay time	t_{pd1}		20	60	150	ns
Data output hold time	t_{pd2}		20	40	100	ns

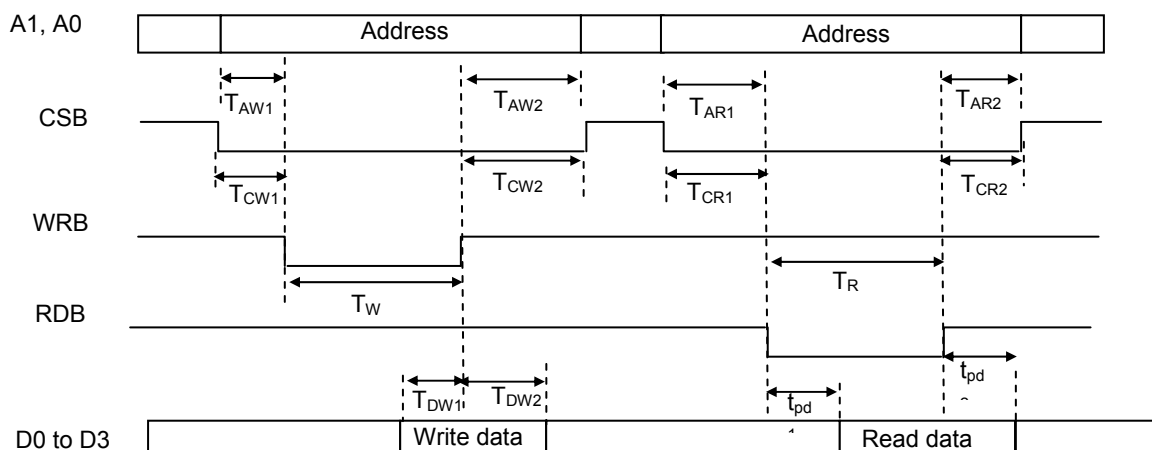

Figure 5 Processor interface timing

FUNCTIONAL DESCRIPTION

Description of Processor Interface

- List of Registers

Table 1 List of processor interface registers

A1	A0	R/W	D3	D2	D1	D0
0	0	W	PBG3	PBG2	PBG1	PBG0
0	1	R/W	SW1 CONT	MODE2	MODE1	MODE0
1	0	R/W	SW3 CONT	SW2 CONT	CPTG ON	CPT800
1	1	R/W	SW5 CONT	SW4 CONT	MOD-DT ON	ATT
0	0	R	PBR3	PBR2	PBR1	PBR0

- * Data written into the registers other than the register [(A1, A0)=(0,0)] can be read out.
- * Immediately after switching ON the power, use the LSI only after clearing the control registers using the power down mode.

- PBG3 to 0/PBR3 to 0

The registers PBG3 to 0 are used for setting the DTMF transmit data.

The registers PBR3 to 0 are used for reading the DTMF receive data.

The output frequency does not change even if the code is changed during transmission.

Table 2 shows the data assignments.

Table 2 DTMF transmit/receive data assignments

D3	D2	D1	D0	CODE	Lower group frequency (Hz)	Higher group frequency (Hz)
PBG3/ PBR3	PBG2/ PBR2	PBG1/ PBR1	PBG0/ PBR0			
0	0	0	1	1	697	1209
0	0	1	0	2	697	1336
0	0	1	1	3	697	1477
0	1	0	0	4	770	1209
0	1	0	1	5	770	1336
0	1	1	0	6	770	1477
0	1	1	1	7	852	1209
1	0	0	0	8	852	1336
1	0	0	1	9	852	1477
1	0	1	0	0	941	1336
1	0	1	1	*	941	1209
1	1	0	0	#	941	1477
1	1	0	1	A	697	1633
1	1	1	0	B	770	1633
1	1	1	1	C	852	1633
0	0	0	0	D	941	1633

- MODE2 to MODE0

These registers are used for setting the mode. The contents of setting are shown in Table 3.

Table 3 List of mode settings

MODE2	MODE1	MODE0	Mode name	Operation of different blocks					
				Modulator section	Demodulator section	DTMF transmission	DTMF reception	CPT transmission	CPT reception
0	0	0	Modem transmission	O	–	–	–	O	–
0	0	1	Modem reception	–	O	–	–	O	–
0	1	0	Tone 1 (Note 1)	–	–	–	O	O	–
0	1	1	Tone 2 (Note 1)	–	–	O	O	O	O
1	0	0	Tone 3 (Note 1)	–	–	O	O	O	O
1	0	1	Loop back (Note 2)	O	O	O	O	–	–
1	1	0	Test	LSI internal test					
1	1	1	Power down (Note 3)	–	–	–	–	–	–

*[O]: Operating condition, [–]: Power down condition

Note 1: Tone 1, 2, 3 modes

The DTMF detection timing is different in the tone 1, 2, loop back modes from that in the tone 3 mode.

In the tone 3 mode, the DTMF detection goes into the high speed detection mode. In this mode, since the detector can make incorrect detection due to voice signals or noise, avoid using the tone 3 mode if there is any margin available in the timing.

Note 2: Loop back mode

The modem loop back mode is initiated when SW5CONT is High and MOD-DT_ON is High. (The data input in XD is output from RD via the internal circuits.)

The DTMF loop back mode is initiated when SW5CONT is Low and MOD-DT_ON is High. (The data set in PBG3 to PBG0 is latched at the rising edge of MOD-DT_ON, and is output at PBR3 to PBR0 via the internal circuits.)

Note 3: Power down mode

The conditions when the LSI is put in the power down mode are listed below.

Each blocks:	Stop operating and the internal circuits are reset.
Analog output pins:	Go to the high-impedance state
DET _B , RD, CLK _O pins:	High level
SP, X2 pins:	Low level
Processor interface registers:	Low level (excepting SW1CONT, MODE2, 1, 0)

- **SW1CONT**
This is the switch for selecting the DTMF reception input.
0: The input amplifier 1 is connected to the DTMF reception circuit.
1: The input amplifier 2 is connected to the DTMF reception circuit.
- **SW2CONT**
This is the switch for selecting the modem reception and CPT detection inputs.
0: The input amplifier 2 is connected to the modem reception circuit and the CPT detection circuit.
1: The input amplifier 3 is connected to the modem reception circuit and the CPT detection circuit.
- **SW3CONT**
This is the switch for external circuits, and can be used for connecting the termination, etc.
0: The switch goes into the OFF state.
1: The switch goes into the ON state. (The SW1 pin and the SGO pin are connected together.)
- **SW4CONT**
This is the switch for selecting the signal (TO) of the output amplifier 1.
0: The CPT transmit output is connected to the output amplifier 1.
1: The output signal of SW2 is connected to the output amplifier 1.
- **SW5CONT**
This is the switch for selecting the signal (LO-, LO+) of the output amplifier 2.
0: The DTMF transmit output is connected to the output amplifier 2.
1: The modem transmit output is connected to the output amplifier 2.
Set this to “1” during the modem transmit mode and set this to “0” during the DTMF transmit mode.
- **CPTG_ON**
This register is used for the ON/OFF control of call progress tone transmission.
0: CPT transmission becomes OFF and the signal is not output.
1: CPT transmission becomes ON and the signal is output.
- **CPT800**
This selects the frequency of call progress tone transmission.
0: A 400 Hz signal is output.
1: An 800 Hz signal is output.
- **MOD-DT_ON**
This is used for the ON/OFF control of modem transmission or DTMF transmission.
The transmission function is made ON/OFF of the block corresponding to the selected mode.
0: Modem transmission or DTMF transmission become OFF and the signal is not output.
1: Modem transmission or DTMF transmission become ON and the signal is output.
In the DTMF transmission mode or in the DTMF loop back mode, PBG3 to 0 are latched at the rising edge of MOD-DT_ON.
Set this to “0” during the modem reception mode and the tone 1 mode.
- **ATT**
This controls the attenuator of the DTMF transmission section.
0: No attenuator is inserted. The DTMF transmit signal is output as it is.
1: A -6 dB attenuator is inserted in the DTMF transmission section.

APPLICATION CIRCUIT EXAMPLE

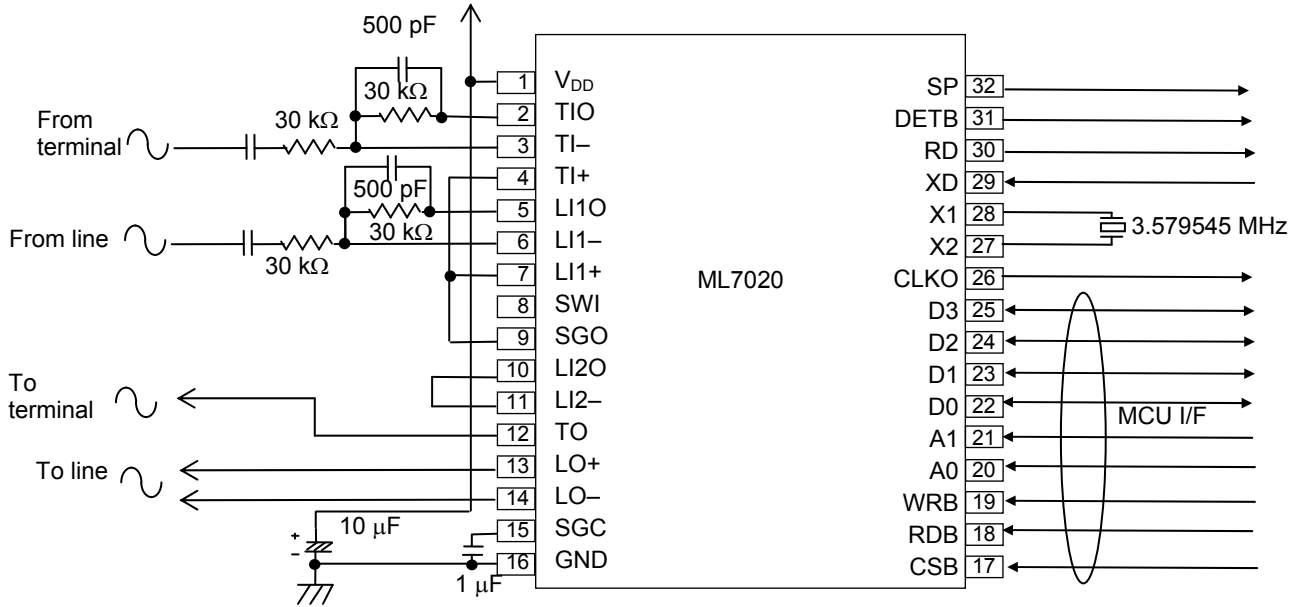

PACKAGE DIMENSIONS

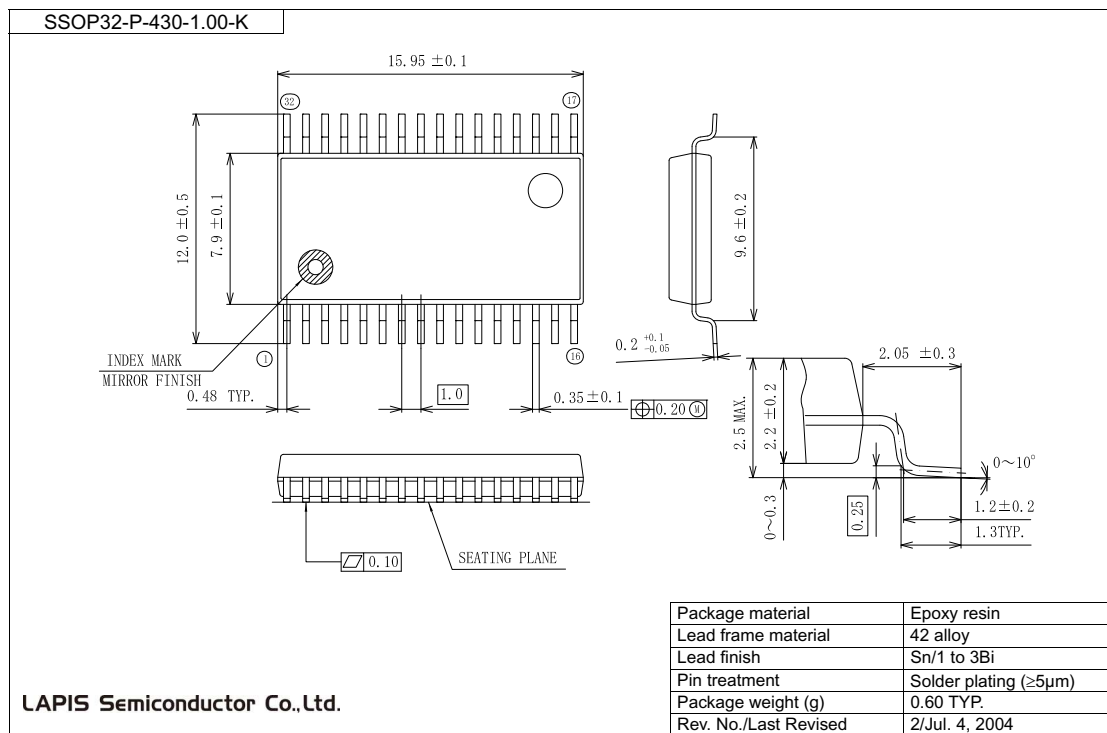

(Unit : mm)

Notes for Mounting the Surface Mount Type Package

The surface mount type packages are very susceptible to heat in reflow mounting and humidity absorbed in storage.

Therefore, before you perform reflow mounting, contact ROHM's responsible sales person for the product name, package name, pin number, package code, and desired mounting conditions (reflow method, temperature and times).

REVISION HISTORY

Document No.	Date	Page		Description
		Previous Edition	Current Edition	
FEDL7020-03	Mar. 30, 2007	-	-	Final edition 3

NOTICE

No copying or reproduction of this document, in part or in whole, is permitted without the consent of LAPIS Semiconductor Co., Ltd.

The content specified herein is subject to change for improvement without notice.

The content specified herein is for the purpose of introducing LAPIS Semiconductor's products (hereinafter "Products"). If you wish to use any such Product, please be sure to refer to the specifications, which can be obtained from LAPIS Semiconductor upon request.

Examples of application circuits, circuit constants and any other information contained herein illustrate the standard usage and operations of the Products. The peripheral conditions must be taken into account when designing circuits for mass production.

Great care was taken in ensuring the accuracy of the information specified in this document. However, should you incur any damage arising from any inaccuracy or misprint of such information, LAPIS Semiconductor shall bear no responsibility for such damage.

The technical information specified herein is intended only to show the typical functions of and examples of application circuits for the Products. LAPIS Semiconductor does not grant you, explicitly or implicitly, any license to use or exercise intellectual property or other rights held by LAPIS Semiconductor and other parties. LAPIS Semiconductor shall bear no responsibility whatsoever for any dispute arising from the use of such technical information.

The Products specified in this document are intended to be used with general-use electronic equipment or devices (such as audio visual equipment, office-automation equipment, communication devices, electronic appliances and amusement devices).

The Products specified in this document are not designed to be radiation tolerant.

While LAPIS Semiconductor always makes efforts to enhance the quality and reliability of its Products, a Product may fail or malfunction for a variety of reasons.

Please be sure to implement in your equipment using the Products safety measures to guard against the possibility of physical injury, fire or any other damage caused in the event of the failure of any Product, such as derating, redundancy, fire control and fail-safe designs. LAPIS Semiconductor shall bear no responsibility whatsoever for your use of any Product outside of the prescribed scope or not in accordance with the instruction manual.

The Products are not designed or manufactured to be used with any equipment, device or system which requires an extremely high level of reliability the failure or malfunction of which may result in a direct threat to human life or create a risk of human injury (such as a medical instrument, transportation equipment, aerospace machinery, nuclear-reactor controller, fuel-controller or other safety device). LAPIS Semiconductor shall bear no responsibility in any way for use of any of the Products for the above special purposes. If a Product is intended to be used for any such special purpose, please contact a ROHM sales representative before purchasing.

If you intend to export or ship overseas any Product or technology specified herein that may be controlled under the Foreign Exchange and the Foreign Trade Law, you will be required to obtain a license or permit under the Law.

Copyright 2011 LAPIS Semiconductor Co., Ltd.