ML7005

DTMF Transceiver

GENERAL DESCRIPTION

The ML7005 is a multi-functional DTMF transceiver LSI with built-in a DTMF signal generator, a DTMF signal receiver, a call progress tone generator, a call progress tone detector, and a FAX (FX) signal detector.

Each functional block can be controlled by an external MCU via a 4-bit processor interface.

The ML7005 does not contains a modem.

However, the DTMF system data transmission is possible at less than 66 bps by setting the DTMF receiver to the high-speed detection mode.

The ML7005 operates with low-power consumption and is suitable for remote control systems, especially for ACR (Automatic Cost Routing) controllers.

FEATURES

- Wide range of power supply voltage : +2.7 V to +5.5 V
- Low power consumption
 - Operating mode : 4.0 mA (VDD = 3 V) Typ.
 - Operating mode : 5.0 mA (VDD = 5 V) Typ.
 - Power down mode : 1 mA Typ.
- The 4-bit processor interface supports both the Intel processor mode in which a read signal and a write signal are used independently of each other, and the Motorola processor mode in which a read signal and a write signal are used in common.
- The DTMF receiver can select either the high-speed detection mode (signal repeat time: more than 60 ms) or the normal detection mode (signal repeat time: more than 90 ms).
- Built-in call progress tone generator
- Built-in FAX signal (FX: 1300 Hz) detector
- The DTMF signal generator, DTMF signal detector, call progress tone generator, and call progress tone detector can operate concurrently.
- Built-in 3.579545 MHz crystal oscillator circuit
- Package :
 - 32-pin plastic SSOP (SSOP32-P-430-1.00-K) (Product name: ML7005MB)

BLOCK DIAGRAM

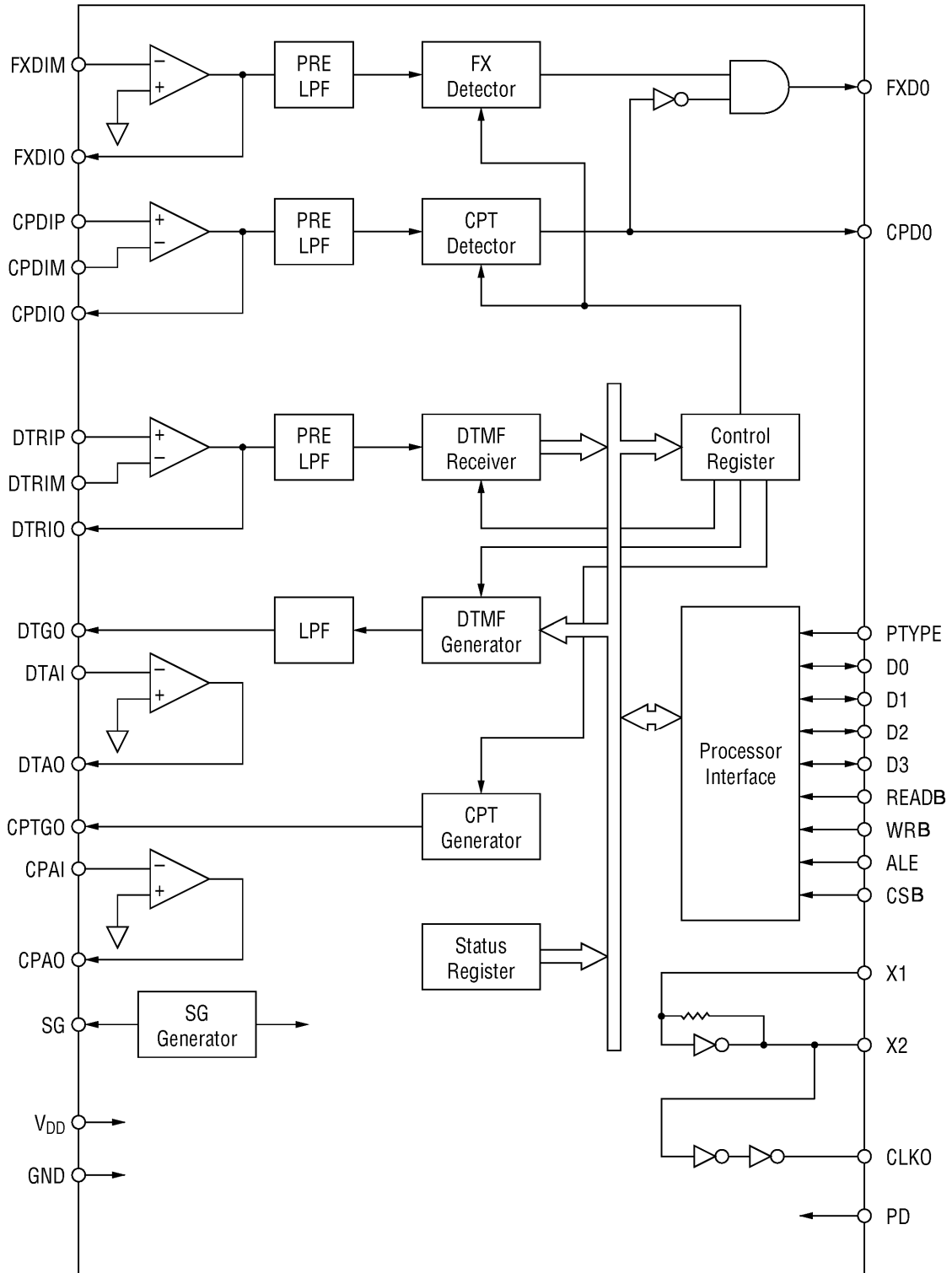

PIN CONFIGURATION (TOP VIEW)

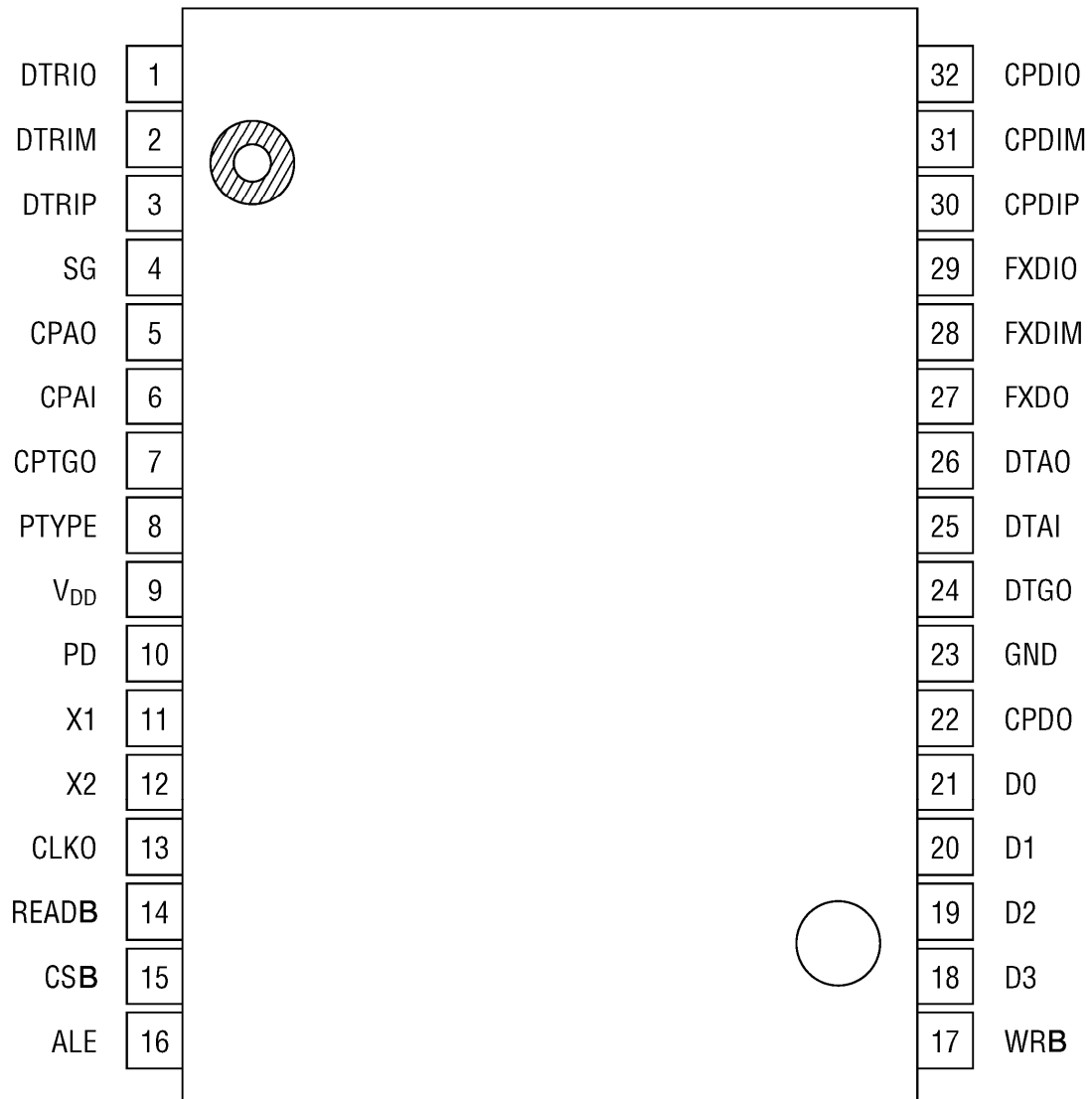

32-Pin Plastic SSOP

PIN DESCRIPTION

Symbol	Pin	Type	Description
DTRIO	1	OUT	Output pin for DTMF signal receiver input amplifier. See the figure 8 for adjusting the receive signal level. See the figure 10 when the DTMF signal receiver is not used.
DTRIM	2	IN	Inverting input pin for DTMF signal receiver input amplifier.
DTRIP	3	IN	Non-inverting input pin for DTMF signal receiver input amplifier.
SG	4	OUT	Output pin for signal ground. The output voltage is half of VDD. Connect SG and GND by a 1 μ F capacitor. This pin goes to a high impedance state when in power down mode.
CPAO	5	OUT	Output pin for amplifier used for adjusting the transmit output level of CPT (Call Progress Tone) signal generator. The non-inverting input of this amplifier is internally connected to SG. See the figure 11 for adjusting the transmit signal level. When this amplifier is not used, the CPAO pin should be shorted to the CPAI pin.
CPAI	6	IN	Inverting input pin for amplifier used to adjust the transmit level of the CPT signal generator.
CPTGO	7	OUT	Analog output pin for CPT signal generator. The tone amplitude is approximately -3 dBm. The transmit signal level can be changed by using the CPAO and CPAI pins. See the figure 11 for adjusting the transmit signal level. Control the ON/OFF of CPT transmission by using CPGC of the control register.
PTYPE	8	IN	Input pin for selecting the processor mode. This selection determines the functions of READB, CSB, ALE, WRB, D1 and D0 pins. When this pin is "1", the Intel processor mode is selected. When this pin is "0", the Motorola processor mode (MSM7524-compatible) is selected. This pin should be fixed at "0" or "1".
VDD	9	—	Power supply pin.
PD	10	IN	Input pin for controlling the power down mode. When this pin is set to "1", the entire LSI enters the power down mode and each functional operation stops. The DC level of the analog output pin becomes undefined. The digital output pins (FXD0, CPD0) and status register indicate a non-detection state. At that time, the control register CR and DTMF transmit register DTMFT are cleared. ("0" is written) The internal circuits (timer, etc. for each detector) also are reset. After turning on the power, set this pin to "1" to reset the LSI before using this LSI. When this pin is set to "0", the normal operation starts.
X1	11	IN	X1 and X2 are connected to a 3.579545 MHz crystal.
X2	12	OUT	See "Oscillation Circuit" of the FUNCTIONAL DESCRIPTION for reference.
CLKO	13	OUT	3.579545 MHz clock output pin. This pin can drive one ML7005 device.

Symbol	Pin	Type	Description
READB	14	IN	<p>Input pin for processor interface.</p> <p>When PTYPE is "1" (Intel processor mode) :</p> <p>This pin is the read control input pin.</p> <p>When this pin is set to "0", data in the specified register is output to the bus lines (D3 to D0).</p> <p>At that time, CSB must be "0".</p> <p>See the figure 4 for processor interface timing.</p> <p>When PTYPE is "0" (Motorola processor mode) :</p> <p>This pin is the clock input pin (equivalent to SCLK of the MSM7524).</p> <p>When in Write mode, data in D3 to D0 is written to the specified register at the falling edge of the READB signal.</p> <p>When in Read mode, data in the specified register is output to D3 to D0 when the READB signal is "1", and D3 to D0 is opened when the READB signal is "0".</p> <p>The READB signal is not necessarily a periodical signal.</p> <p>See the figure 5 for processor interface timing.</p>
CSB	15	IN	<p>Chip select input pin for processor interface.</p> <p>When the CSB signal is "0", read and write operations are possible.</p> <p>When the CSB signal is "1", read and write operations are impossible.</p>
ALE	16	IN	<p>Input pin for processor interface.</p> <p>When PTYPE is "1" (Intel processor mode) :</p> <p>This pin is the address latch enable input pin.</p> <p>The register address data in D1 to D0 is latched at the falling edge of ALE.</p> <p>When PTYPE is "0" (Motorola processor mode) :</p> <p>This pin is the address data input pin (equivalent to AD0 of the MSM7524).</p> <p>When this pin is "1", data can be written to the control register (CR) and data can be read from the status register (STR).</p> <p>When this pin is "0", data can be written to the DTMF transmit register (DTMFT) and data can be read from the DTMF receive register (DTMFR).</p>
WRB	17	IN	<p>Input pin for processor interface.</p> <p>When PTYPE is "1" (Intel processor mode) :</p> <p>This pin is the Write control input.</p> <p>Data in the data bus lines (D3 to D0) is written to the specified register.</p> <p>At that time, CSB must be "0".</p> <p>When PTYPE is "0" (Motorola processor mode) :</p> <p>This is the signal input pin for controlling the Read and Write modes (equivalent to R/W of the MSM7524).</p> <p>When this pin is "1", the LSI enters the Read mode.</p> <p>When this pin is "0", the LSI enters the Write mode.</p>
D3 to D0	18 to 21	I/O	<p>4-bit data bus I/O pins for processor interface.</p> <p>When PTYPE is "1" (Intel processor mode), D1 and D0 are also used for addressing.</p>

Symbol	Pin	Type	Description
CPDO	22	OUT	Digital output pin for CPT detector. When a 400 Hz signal is input to the CPDIP and CPDIM pins, this pin is "1". When the DOEN register is "0", this pin is fixed at "0".
GND	23	—	Ground pin.
DTGO	24	OUT	Analog output pin for DTMF signal generator. The tone amplitude is approximately -9.0 dBm for a low group and approximately -7.0 dBm for a high group. The transmit signal level can be changed by using the DTAI and DTAO pins. See the figure 11 for adjusting the transmit signal level. Control the ON/OFF of signal transmission by using MFC of the control register.
DTAI	25	IN	Inverting input pin for operational amplifier used for adjusting the transmit output level of the DTMF signal generator. The non-inverting input of this amplifier is internally connected to SG. See the figure 11 for adjusting the transmit signal level. When this amplifier is not used, the DTAO pin should be shorted to the DTAI pin.
DTAO	26	OUT	Output pin for operational amplifier used for adjusting the transmit output level of the DTMF signal generator.
FXDO	27	OUT	Digital output pin for FAX signal (FX) detector. When a 1300 Hz signal is input to the FXDIM, this pin is "1". When a call progress tone (CPT) is received (CPD0="1"), this pin is forced to be "0". When the DOEN register is "0", this pin is fixed at "0".
FXDIM	28	IN	Inverting input pin for input amplifier used for detecting the FAX signal (FX). See the figure 9 for adjusting the receive signal level. When the FX detector is not used, the FXDIM pin should be shorted to the FXDIO pin.
FXDIO	29	OUT	Output pin for input amplifier used for detecting the FAX signal (FX).
CPDIP	30	IN	Non-inverting input pin for input amplifier used for detecting the CPT. See the figure 8 for adjusting the receive signal level. When the CPT detector is not used, see the figure 10.
CPDIM	31	IN	Inverting input pin for input amplifier used for detecting the CPT.
CPDIO	32	OUT	Output pin for input amplifier used for detecting the CPT.

ABSOLUTE MAXIMUM RATINGS

Parameter	Symbol	Condition	Rating	Unit
Power Supply Voltage	V_{DD}	Ta = 25°C With respect to GND	-0.3 to +7	V
Input Voltage	V_I		-0.3 to $V_{DD}+0.3$	V
Storage Temperature	T_{STG}	—	-55 to +150	°C
Output Short Current	I_{SHT}	Short to VDD or GND	35	mA
Power Dissipation	P_D	—	100	mW

RECOMMENDED OPERATING CONDITIONS

Parameter	Symbol	Condition	Min.	Typ.	Max.	Unit	
Power supply voltage	V_{DD}	—	+2.7	+3.6	+5.5	V	
Operating Temperature Range	T_{OP}	—	-30	—	+85	°C	
Input Clock Frequency Deviation	f_{CLK}	An external clock is applied to X1	-0.1	—	+0.1	%	
Input Clock duty	DUTY		40	—	60	%	
X1, X2 Load Capacitance	C1,C2	—	18	20	22	pF	
SG Bypass Capacitance	C3	SG - GND	1	—	—	μF	
VDD Bypass Capacitance	C4	VDD - GND	10	—	—		
	C5		0.1	—	—		
Digital Input Rise Time	t_{IR}	PD, READB, CSB, ALE, WRB, D3 to D0	—	—	50	ns	
Digital Input Fall Time	t_{IF}		—	—	50		
Digital Output Load Capacitance	C_{DL1}	FXDO, CPDO, D3 to D0	—	—	40	pF	
	C_{DL2}	CLKO	—	—	20		
Crystal	Frequency Deviation	—	+25°C ±5°C	-100	—	+100	ppm
	Temperature Characteristics	—	-30°C to +85°C	-100	—	+100	
	Equivalent Series Resistance	—	—	—	—	90	Ω
	Load Capacitance	—	—	—	16	—	pF

ELECTRICAL CHARACTERISTICS

DC and Digital Interface Characteristics

($V_{DD}=+2.7$ to $+5.5$ V, $T_a=-30$ to $+85^{\circ}\text{C}$)

Parameter	Symbol	Condition	Min.	Typ.	Max.	Unit	
Power Supply Current	I_{DD1}	$V_{DD}=+2.7$ to $+5.5$ V	—	—	9.0	mA	
		Operating Mode	$V_{DD}=+3$ V	—	4.0		—
			$V_{DD}=+5$ V	—	5.0		—
	I_{DD2}	Power Down Mode	—	1	40	μA	
Digital Input Voltage	V_{IH}	—	$0.7V_{DD}$	—	V_{DD}	V	
	V_{IL}		0.0	—	$0.3V_{DD}$		
Digital Input Current	I_{IH}	$V_I = V_{DD}$	-10	0	10	μA	
	I_{IL}	$V_I = 0$ V	-10	0	10		
Digital Output Voltage	V_{OH}	Other than CLK0	$I_{OH} = -100\mu\text{A}$	$V_{DD} - 0.2$	$V_{DD} - 0.06$	V_{DD}	
	V_{OL}		$I_{OL} = 100\mu\text{A}$	0.0	0.06		0.2
	V_{OHCK}	CLK0, $CL \leq 20\text{pF}$		$V_{DD}-0.5$	—	V_{DD}	
	V_{OLCK}			0.0	—	0.5	
Analog Input Resistance	R_{IN}	*1	—	10	—	$\text{M}\Omega$	
Analog Output DC Potential	V_{SG}	SG	$V_{DD}/2-0.1$	$V_{DD}/2$	$V_{DD}/2+0.1$	V	
	V_{AO}	*2	—	$V_{DD}/2$	—		
Analog Output Load Resistance	R_{OUT}	*3	20	—	—	$\text{k}\Omega$	

*1 DTRIM, DTRIP, CPAI, DTAI, FXDIM, CPDIP, CPDIM

*2 DTRIO, CPAO, CPTGO, DTGO, DTAO, FXDIO, CPDIO

*3 DTRIO, CPAO, CPTGO, DTGO, DTAO, FXDIO, CPDIO, SG

AC CHARACTERISTICS

AC Characteristics 1 DTMF Signal Generator

($V_{DD}=+2.7$ to $+5.5$ V, $T_a=-30$ to $+85^{\circ}\text{C}$)

Parameter	Symbol	Condition	Min.	Typ.	Max.	Unit	
DTMF Tone Transmit Amplitude	V_{DTTL}	Measured at DTGO	Low Group Tone	-10.5	-9.0	-7.5	dBm
	V_{DTTH}		High Group Tone	-8.5	-7.0	-5.5	
Tone Transmit Amplitude Ratio	V_{DTDF}		$V_{DTTH} - V_{DTTL}$	1.0	2.0	3.0	dB
Tone Frequency Accuracy	f_{DDT}		To Nominal Frequency	-1.5	—	+1.5	%
Total Harmonic Distortion	THD_{DT}		Harmonics - Fundamental	—	-40	-23	dB
Out-of-Band Spurious	V_{S1}	With respect to output signal level measured at DTGO	4kHz to 8kHz	—	P - 51	P - 20	dB
	V_{S2}		8kHz to 12kHz	—	P - 60	P - 40	
	V_{S3}		12kHz to each 4kHz band	—	P - 75	P - 60	

*1 0dBm = 0.775 Vrms (For all AC characteristics)

AC Characteristics 2 Call Progress Tone (CPT) Generator

($V_{DD}=+2.7$ to $+5.5$ V, $T_a=-30$ to $+85^{\circ}\text{C}$)

Parameter	Symbol	Condition	Min.	Typ.	Max.	Unit
Tone Transmit Amplitude	V_{CPT}	—	-4	-2.5	-1	dBm
Output Frequency	f_{CPT}	—	380	400	420	Hz
Total Harmonic Distortion	THD_{CPT}	Harmonics - Fundamental	—	-39	-23	dB

AC Characteristics 3 Call Progress Tone (CPT) Detector

($V_{DD}=+2.7$ to $+5.5$ V, $T_a=-30$ to $+85^{\circ}\text{C}$)

Parameter	Symbol	Condition	Min.	Typ.	Max.	Unit
CPT Detect Amplitude	V_{DETC}	$2.7\text{V} \leq V_{DD} \leq 5.5\text{V}$	-46	—	-6	dBm
		$4.5\text{V} \leq V_{DD} \leq 5.5\text{V}$	-46	—	0	
CPT Non-detect Amplitude	V_{REJCP}	$f_{in}=350$ to 450 Hz at CPDIO	—	—	-60	
Time to Detect	t_{DETC}	See Figure 1.	Detect	30	—	ms
Time to Reject	t_{REJCP}		Non-detect	—	—	
CPT Detect Delay Time	t_{DELCP}		10	18	30	ms
CPT Detect Hold Time	t_{HOLCP}		10	18	30	
CPT Detect Frequency	f_{DETC}	—	350	—	450	Hz
CPT Non-detect Frequency	f_{RETC}		530	—	—	Hz
			—	—	290	

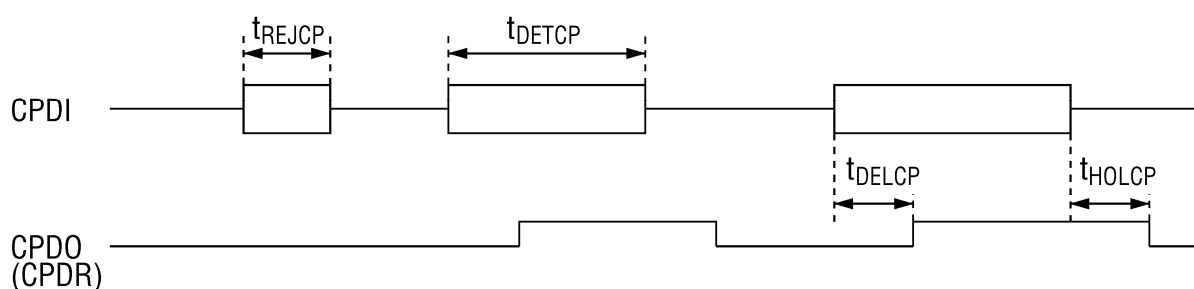

Figure 1 CPT Detect Timing

AC Characteristics 4 FAX Signal (FX) Detector

 $(V_{DD}=+2.7$ to $+5.5$ V, $T_a=-30$ to $+85^{\circ}\text{C}$)

Parameter	Symbol	Condition	Min.	Typ.	Max.	Unit	
FX Detect Amplitude	V_{DETFX}	$2.7\text{V} \leq V_{\text{DD}} \leq 5.5\text{V}$	-40	—	-6	dBm	
		$4.5\text{V} \leq V_{\text{DD}} \leq 5.5\text{V}$	-40	—	0		
FX Non-detect Amplitude	V_{REJFX}	$f_{\text{in}} = 1280$ to 1320 Hz at CPDIO		—	-60		
Time to Detect	t_{DETFX}	See Figure 2.	Detect	65	—	ms	
Time to Reject	t_{REJFX}		Non-detect	—	—		30
FX Detect Delay Time	t_{DELFX}			35	50	65	ms
FX Detect Hold Time	t_{HOLFX}			35	50	65	
FX Detect Frequency	f_{DETFX}	—	1280	—	1320	Hz	
FX Non-detect Frequency	f_{RETFX}	—	1380	—	—	Hz	
			—	—	1200		

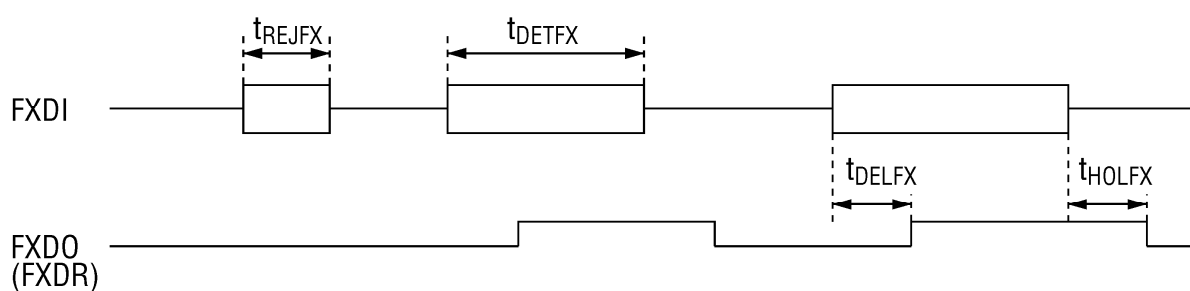

Figure 2 FX Detect Timing

AC Characteristics 5 DTMF Receiver

(V_{DD}=+2.7 to +5.5 V, Ta=-30 to +85°C)

Parameter	Symbol	Condition	Min.	Typ.	Max.	Unit		
DTMF Detect Amplitude	V _{DETD1}	2.7V ≤ VDD ≤ 5.5V	-42	—	-10	dBm		
	V _{DETD2}	4.5V ≤ VDD ≤ 5.5V	-42	—	0			
DTMF Non-detect Amplitude μ	V _{REJFX}	Per Frequency at DTRIO	—	—	-60			
Detect Frequency	f _{DETD}	To Nominal Frequency	-1.8	—	+1.8	%		
Non-detect Frequency	f _{REJDT}		+3.8	—	—			
Level Twist	V _{TWIST}	VHigh Group - VLow Group	-6.0	—	+6.0	dB		
Noise to Signal Ratio	V _{NIS}	N/S(N : 0.3 to 3.4kHz)	—	-12	—	dB		
Dial Tone Rejection Ratio	V _{REJDT}	360 to 440Hz	—	45	—	dB		
Signal Repetition Time	t _{CYCDT0}	*1	DTTIM="1"	60	—	—	ms	
	t _{CYCDT1}		DTTIM="0"	90	—	—		
Time to Detect	t _{DETD0}		Detect	DTTIM="1"	35	—		—
	t _{DETD1}			DTTIM="0"	49	—		—
Time to Reject	t _{REJDT0}		Non-detect	DTTIM="1"	—	—		10
	t _{REJDT1}			DTTIM="0"	—	—		24
Interdigit Pause Time	t _{POSDT0}		*1	DTTIM="1"	21	—		—
	t _{POSDT1}			DTTIM="0"	30	—		—
Acceptable Drop Out Time	t _{BRKDT10}		SPB="1" (Before output)	DTTIM="1"	—	—		0.4
				DTTIM="0"	—	—		0.4
	t _{BRKDT20}		SPB="0" (During output)	DTTIM="1"	—	—		3
				DTTIM="0"	—	—		10
Detect Delay Time	t _{DELDT0}		*1	DTTIM="1"	12	26		37
	t _{DELDT1}			DTTIM="0"	24	41		49
Detect Hold Time	t _{HOLDT0}		*1	DTTIM="1"	15	20		27
	t _{HOLDT1}			DTTIM="0"	24	28		35
SPB Delay Time	t _{SP}		DTTIM="1", "0"	0.2	0.6	1.0		

*1 See the figure 3 for timing.

The input level includes the entire range indicated in V_{DETD1} and V_{DETD2}.The input frequency includes the entire range indicated in f_{DETD}.

Timing When DTMF is received

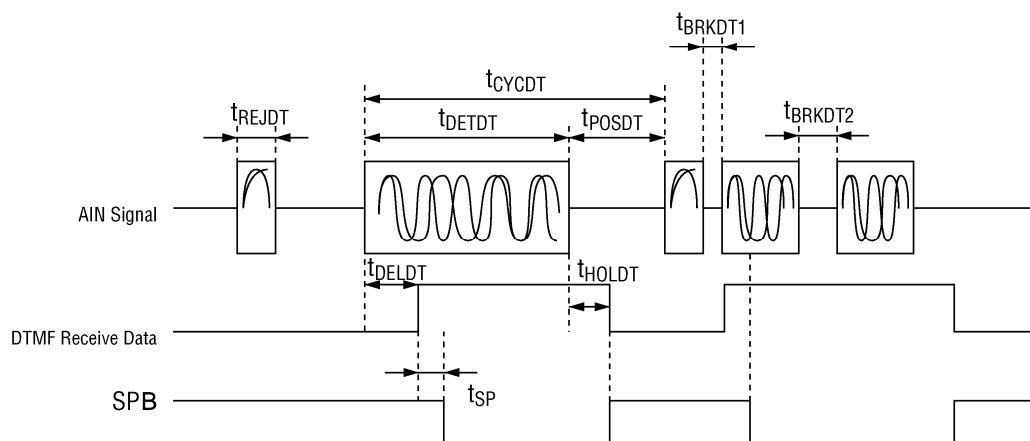

Figure 3 Timing When DTMF is Received

 t_{DEJDT} : Time to Detect

When Time to Detect is the specified value of t_{DEJDT} or more, the DTMF signal is normally received.

 t_{REJDT} : Time to Reject

When Time to Reject is the specified value of t_{REJDT} or less, the input signal is ignored and the SPB and DTMF receive data are not output.

 t_{POSdT} : Interdigit Pause

When there is no input signal for the period of t_{POSdT} or more, the DTMF receive data and SPB are reset.

Even if the receive data is changed, when Interdigit Pause Time is the value of t_{POSdT} or less (including the change without Drop Out), SPB remains at "0" and the DTMF receive data may maintain its initial value.

 t_{BRKDT1} : Acceptable Drop Out Time 1

Acceptable Drop Out Time 1 is applied between when the input signal comes and when SPB becomes "0".

Even if there is no input signal for the period of t_{BRKDT1} or less, the SPB and DTMF receive data are normally output.

 t_{BRKDT2} : Acceptable Drop Out Time 2

Acceptable Drop Out Time 2 is applied when SPB is "0" (when receive data is output).

Even if there is no input signal during signal reception for the period of t_{BRKDT2} or less, SPB and DTMF receive data are not reset.

 t_{CYCDT} : Signal Repetition Time

Signal Repetition Time should be the specified value of t_{CYCDT} or more so that a signal is normally received.

 t_{DELDT} : Detect Delay Time

The DTMF receive data is output with a delay of the specified value of t_{DELDT} after the input signal appears.

 t_{HOLDT} : Detect Hold Time

The SPB and DTMF receive data outputs stop with a delay of the specified value of t_{HOLDT} after the input signal disappears.

 t_{SP} : SPB Delay Time

The SPB data is output with a delay of the specified value of t_{SP} after the DTMF receive data is output.

The DTMF receive data should be latched after detecting the fall of SPB.

Processor Interface Characteristics (Intel Processor Mode)

 $(V_{DD}=+2.7$ to $+5.5$ V, $T_a=-30$ to $+85^{\circ}\text{C}$)

Parameter	Symbol	Condition	Min.	Typ.	Max.	Unit
Address Data Setup Time	t_{AL}	—	80	—	—	ns
Address Data Hold Time	t_{LA}	—	30	—	—	ns
ALE Signal Time	t_{LL}	—	80	—	—	ns
Chip Select Setup Time before Read	t_{CRS}	—	30	—	—	ns
Chip Select Hold Time after Read	t_{CRH}	—	30	—	—	ns
READB Data Output Delay Time	t_{RD}	$V_{OL} \leq 0.4$ V, $V_{OH} \geq V_{DD} - 0.4$ V	0	90	180	ns
Data Float Time after Read	t_{RDF}	—	5	37	60	ns
READB Signal Time	t_{RW}	—	200	—	—	ns
Chip Select Setup Time before Write	t_{CWS}	—	30	—	—	ns
Chip Select Hold Time after Write	t_{CWH}	—	30	—	—	ns
WRB Signal Time	t_{WW}	—	140	—	—	ns
Data Setup Time before Write	t_{DW}	—	80	—	—	ns
Data Hold Time	t_{WD}	—	30	—	—	ns

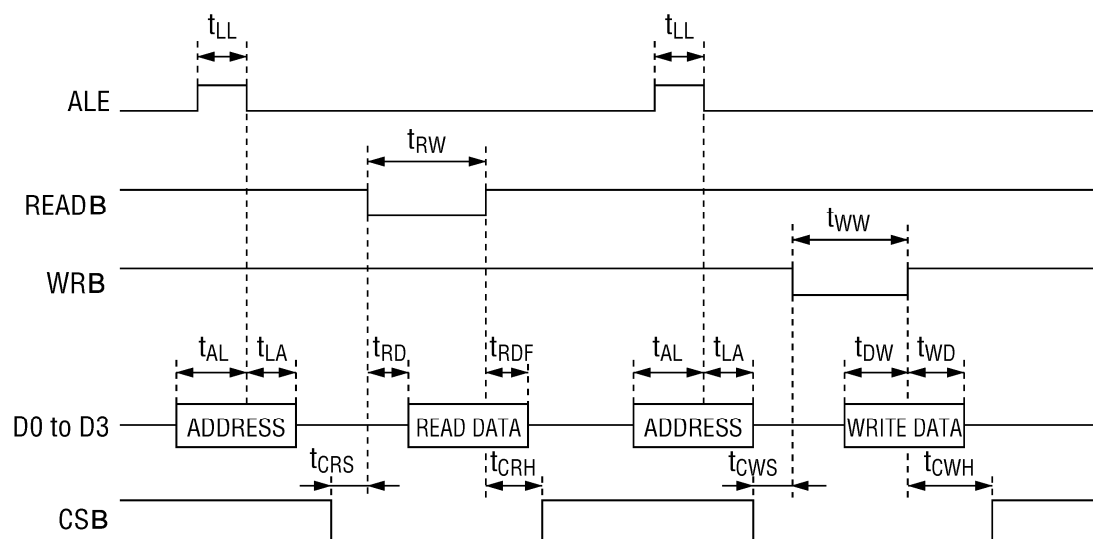

Figure 4 Processor Interface Timing (Intel Processor Mode : PTYPE="1")

Processor Interface Characteristics (Motorola Processor Mode)

(V_{DD}=+2.7 to +5.5 V, Ta=-30 to +85°C)

Parameter		Symbol	Condition	Min.	Typ.	Max.	Unit
READB Signal Period		t _{CYC}	—	1	—	—	μs
READB Signal Pulse Width		t _{HI}	"H" period	200	—	—	ns
		t _{LO}	"L" period	200	—	—	
ALE	SETUP Time	t _{AS}	ALE→READB	80	—	—	ns
	HOLD Time	t _{AH}	READB→ALE	20	—	—	
CSB	SETUP Time	t _{CS}	CSB→READB	80	—	—	ns
	HOLD Time	t _{CH}	READB→CSB	20	—	—	
WRB	SETUP Time	t _{WRS}	WRB→READB	80	—	—	ns
	HOLD Time	t _{WRH}	READB→WRB	20	—	—	
D3 to D0 (Write)	SETUP Time	t _{DWS}	D3 to D0→READB	80	—	—	ns
	HOLD Time	t _{DWH}	READB→D3 to D0	30	—	—	
D3 to D0 (Read)	Delay Time	t _{DRD}	READB→D3 to D0 VOL ≤ 0.4 V, VOH ≥ VDD - 0.4 V	0	90	180	ns
	Hold Time	t _{DRH}	D3 to D0→READB	5	37	60	

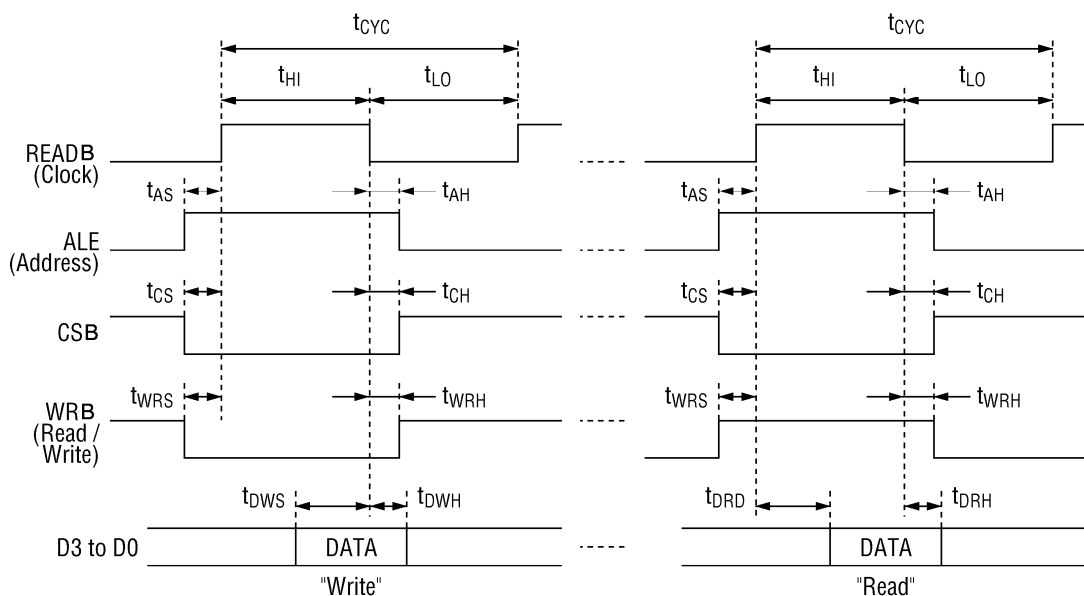

Figure 5 Processor Interface Timing (Motorola Processor Mode)

REGISTER DESCRIPTION

Register Interface Description

The ML7005 contains a 4-bit DTMF transmit data register (DTMFT), a 4-bit DTMF receive data register (DTMFR), a 4-bit control register (CR), and a 4-bit status register (STR).

The DTMFT and CR registers are for Write-only and the DTMFR and STR registers are for Read-only.

When the PTYPE pin is "1", accessing the registers is possible in the Intel processor mode.

When the PTYPE pin is "0", accessing the registers is possible in the Motorola processor mode.

In the Intel processor mode (PTYPE="1"), when CSB is "0", data can be written to the DTMFT and CR registers by fetching data from D3 to D0 at the rising edge of the WRB signal.

When CSB is "0", the contents of DTMFR and STR can be transferred to D3 to D0 by setting READB to "0".

In the Motorola processor mode (PTYPE="0"), when CSB and WRB are "0", data can be written to the DTMFT and CR registers by fetching D3 to D0 data and ALE at the falling edge of READB.

When CSB is "0" and WRB is "1", the contents of DTMFR and STR are transferred to D3 to D0 by latching ALE at the rising edge of READB.

When the PD pin is set to "1" the DTMFT and CR registers are reset.

Table 1 Outline of Registers

Register name	Accessing (address) in Intel processor mode		Accessing in Motorola processor mode		Description
	D1	D0	ALE	WRB	
DTMFT	0	0	0	0	Writing to DTMFT
DTMFR	0	1	0	1	Reading from DTMFR
CR	1	0	1	0	Writing to CR
STR	1	1	1	1	Reading from STR

Note : The contents of the DTMFT and CR registers cannot be read.

Table 2 Register Names

Register name	D3	D2	D1	D0
DTMFT	DTT3	DTT2	DTT1	DTT0
DTMFR	DTR3	DTR2	DTR1	DTR0
CR	CPGC	DTTIM	D0EN	MFC
STR	SPB	FXDR	CPDR	DETF

DTMFT and DTMFR Registers

16 kinds of DTMF transmit signals can be determined by setting the DTMFT register.

16 kinds of DTMF receive signals can be monitored from the DTMFR register.

The table 3 shows the DTMF signal codes.

Even if the DTMF transmit code is changed while the DTMF signal is being transmitted (MFC="1"), the output frequency is not changed.

Table 3 DTMF Signal Code List

DTT3 DTR3	DTT2 DTR2	DTT1 DTR1	DTT0 DTR0	DIGIT	Low group signal (Hz)	High group signal (Hz)
0	0	0	1	1	697	1209
0	0	1	0	2	697	1336
0	0	1	1	3	697	1477
0	1	0	0	4	770	1209
0	1	0	1	5	770	1336
0	1	1	0	6	770	1477
0	1	1	1	7	852	1209
1	0	0	0	8	852	1336
1	0	0	1	9	852	1477
1	0	1	0	0	941	1336
1	0	1	1	*	941	1209
1	1	0	0	#	941	1477
1	1	0	1	A	697	1633
1	1	1	0	B	770	1633
1	1	1	1	C	852	1633
0	0	0	0	D	941	1633

Control Register CR

D3	D2	D1	D0
CPGC	DTTIM	DOEN	MFC

Bit No.	Name	Description
D3	CPGC	This bit is used to control the ON/OFF of call progress tone transmitting. "0" : The GPTGO output is OFF and the SG level is output. "1" : The GPTGO output is ON and CPT is output.
D2	DTTIM	This bit is used to control the detect time of DTMF receiver. "0" : Normal detect "1" : High-speed detect When there is enough time, set to the normal detect mode (DTTIM = "0") because the high-speed detect mode sometimes causes erroneous detection by noise or voice signal.
D1	DOEN	This bit is used to control the call progress tone detector and FX detector. "0" : The CPDO and FXDO output pins and CPDR and FXDR registers are fixed to "0". "1" : The CPDO and FXDO output pins and CPDR and FXDR registers become valid.
D0	MFC	This bit is used to control the ON/OFF of DTMF transmit output. "0" : The DTGO output is OFF and the SG level is output. "1" : The DTGO output is ON and the DTMF signal is output.

Status Register STR

D3	D2	D1	D0
SPB	FXDR	CPDR	DETF

Bit No.	Name	Description
D3	SPB	This bit is used to indicate whether the DTMF receive signal is being received. "0" : Indicates that the valid DTMF signal is being received. "1" : Indicates that the DTMF signal is not being received.
D2	FXDR	This bit is used to indicate whether the FAX signal (FX) is being received. "0" : Indicates that the FAX signal (FX) is not being received. "1" : Indicates that the valid FAX signal (FX: 1300 Hz) is being received. When a call progress tone is received (CPDO="1"), this bit is forced to be "0". When the DOEN register is "0", this bit also is fixed at "0". This bit has the same unction as that of the FXDO.
D1	CPDR	This bit is used to indicate whether the call progress tone is being received. "0" : Indicates that the call progress tone is not being received. "1" : Indicates that the valid call progress tone (400 Hz) is being received. When the DOEN register is "0", this bit is fixed at "0". This bit has the same function as that of the CPDO pin.
D0	DETF	This is a flag to indicate that a detector has changed its status from a non-detect state to a detect state. This bit is "1" when: (1) SPB is changed from "1" to "0", (2) FXDR is changed from "0" to "1", or (3) CPDR is changed from "0" to "1". This bit remains "0" even if a 1300 Hz or 400 Hz signal is input, because the FXDR and CPDR are fixed at "0" when the DOEN regisiter is "0". When the processor has read the status register, this bit is reset to "0". When the processor does not read the status register after a signal is detected, this bit is "0" after the detected signal disappears.

FUNCTIONAL DESCRIPTION

Oscillation Circuit

The X1 and X2 should be connected by a 3.579545 MHz crystal.
 When the load capacitance of the crystal is 16pF, X1 and GND should be connected by a 20 pF capacitor, and X2 and GND also should be connected by a 20 pF capacitor.
 If necessary, an external clock should be input to X1 via a 1000 pF capacitor, and X2 should be left open.

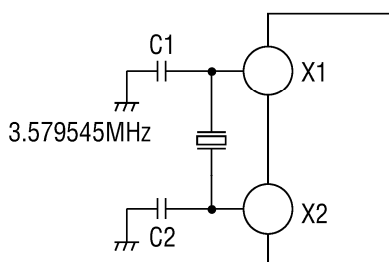

Figure 6 Crystal Connection

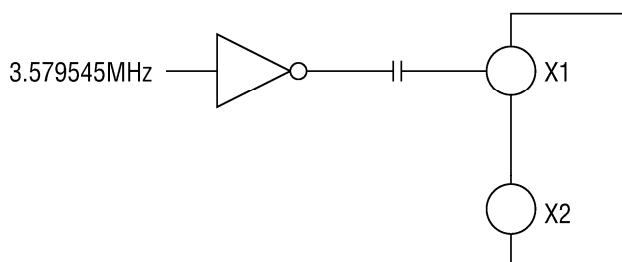

Figure 7 External Clock Connection

DTMF Receiver, CPT Detector Input Level Adjustment

Adjust the input level according to the method shown in the figure 8.
 Determine the value of a usable resistor so that the levels of the outputs (DTIO, CPDIO) of each amplifier at a maximum input level are less than the maximum detect level described in the AC Characteristics.

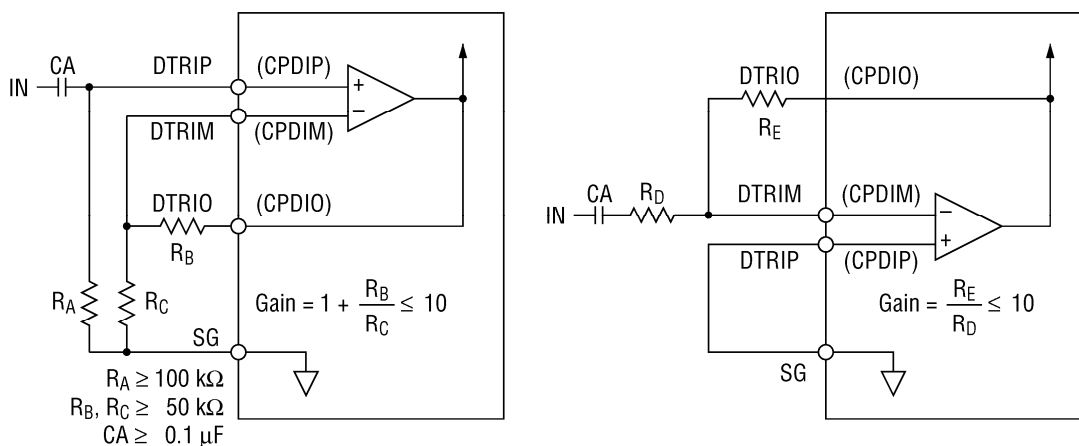

Figure 8 DTMF, CPT Input Level Adjustment

FX Detector Input Level Adjustment

Adjust the input level according to the method shown in the figure 9.

Determine the value of a usable resistor so that the output level of FXDIO is less than the maximum detect level described in the AC Characteristics.

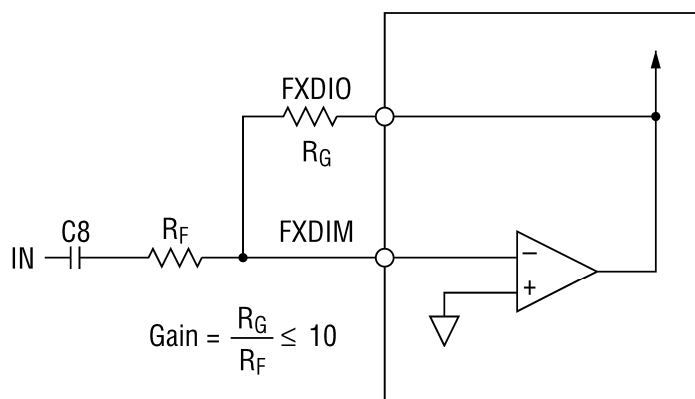

Figure 9 FX Input Level Adjustment

Processing the Input Pin when the DTMF Receiver and CPT Detector are not Used

Process the Input pin according to the method shown in the figure 10.

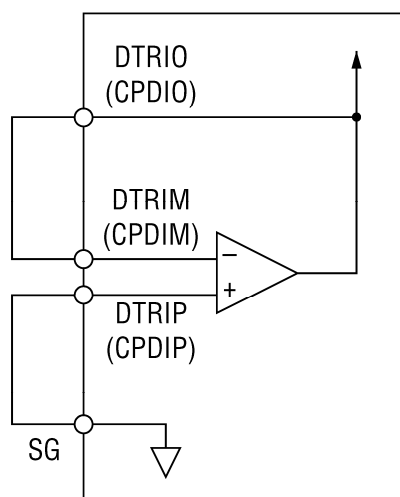

Figure 10 Processing the Unused Input Pin

Adjusting the Analog Output Level

Adjust the analog output level according to the method shown in the figure 11.

$R_I/R_H \leq 1.6$ is always required when $V_{DD} \geq 4.5$ V.

In the case of $R_I/R_H > 1$, if $R_I/R_H = A$, the maximum analog output load resistance is $20 \cdot A$ (k Ω).

If V_{DD} is less than 4.5 V, $R_I/R_H \leq 1$ is required.

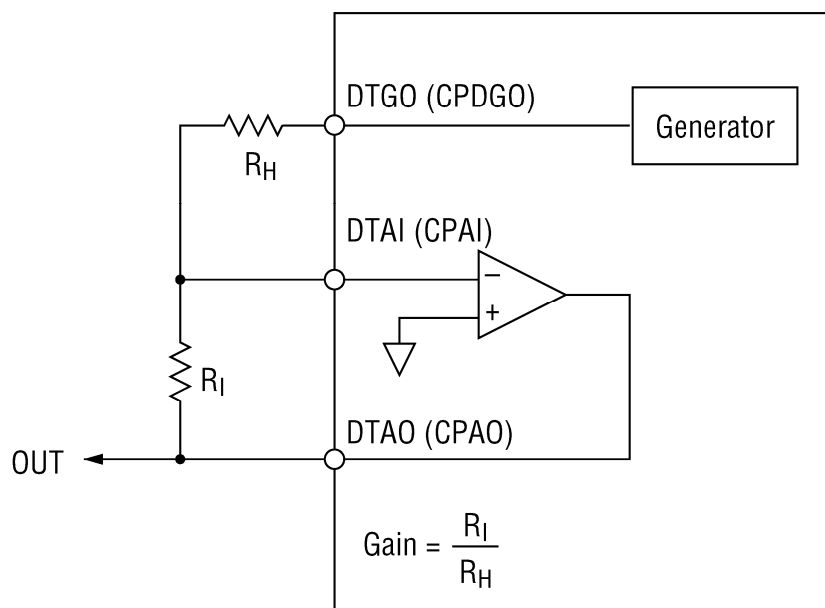

Figure 11 Analog Output Level Adjustment

Concurrent Operation of 4 Functions

The DTMF signal generator, DTMF signal detector, call progress tone generator, and call progress tone detector can operate concurrently.

When both the DTMF signal generator and call progress tone generator operate concurrently, the DTMF signal sometimes cannot be detected if the receive level of the DTMF signal is less than -36 dBm.

Register Settings for Each Mode

An example of register settings for each mode is shown below.

Table 4 Register Setting

Mode	Description	Address in Intel processor mode		Motorola processor mode		D3	D2	D1	D0	Active register
		D1	D0	ALE	WRB					
Power ON	(1) Wait until power supply is stabilized	—	—	—	—	—	—	—	—	—
	(2) PD pin = "1" (internal circuit is reset)	—	—	—	—	—	—	—	—	—
	(3) Wait 200 μs or more	—	—	—	—	—	—	—	—	—
	(4) PD pin = "0"	—	—	—	—	—	—	—	—	—
	(5) CR setting	1	0	1	0	X	X	X	X	CR
DTMF Detect (High Speed)	(1) Detect timing setting	1	0	1	0	0	1	0	0	CR
	(2) STR monitoring (when not detected)	1	1	1	1	1	0	0	0	STR
	(3) STR monitoring (when detected)	1	1	1	1	0	0	0	1	STR
	(4) DTMF receive data reading	0	1	0	1	X	X	X	X	DTMFR
	(5) STR monitoring (when detected and after reading STR)	1	1	1	1	0	0	0	0	STR
	(6) STR monitoring (after making the input signal OFF)	1	1	1	1	1	0	0	0	STR
CPT Detect	(1) CPT detect enable setting	1	0	1	0	0	0	1	0	CR
	(2) STR monitoring (when not detected)	1	1	1	1	1	0	0	0	STR
	(3) STR monitoring (when detected)	1	1	1	1	1	0	1	1	STR
	(4) STR monitoring (when detected and after reading STR)	1	1	1	1	1	0	1	0	STR
DTMF Transmit	(1) DTMF transmit data setting	0	0	0	0	X	X	X	X	DTMFT
	(2) DTMF transmit ON	1	0	1	0	0	0	0	1	CR
	(3) Wait transmit ON time	—	—	—	—	—	—	—	—	—
	(4) DTMF transmit OFF	1	0	1	0	0	0	0	0	CR
	(5) Wait transmit OFF time	—	—	—	—	—	—	—	—	—
	(6) To transmit next data, return to (1)	—	—	—	—	—	—	—	—	—
CPT Transmit	(1) CPT transmit ON	1	0	1	0	1	0	0	0	CR
	(2) Wait transmit ON time	—	—	—	—	—	—	—	—	—
	(3) CPT transmit OFF	1	0	1	0	0	0	0	0	CR

APPLICATION CIRCUIT EXAMPLE

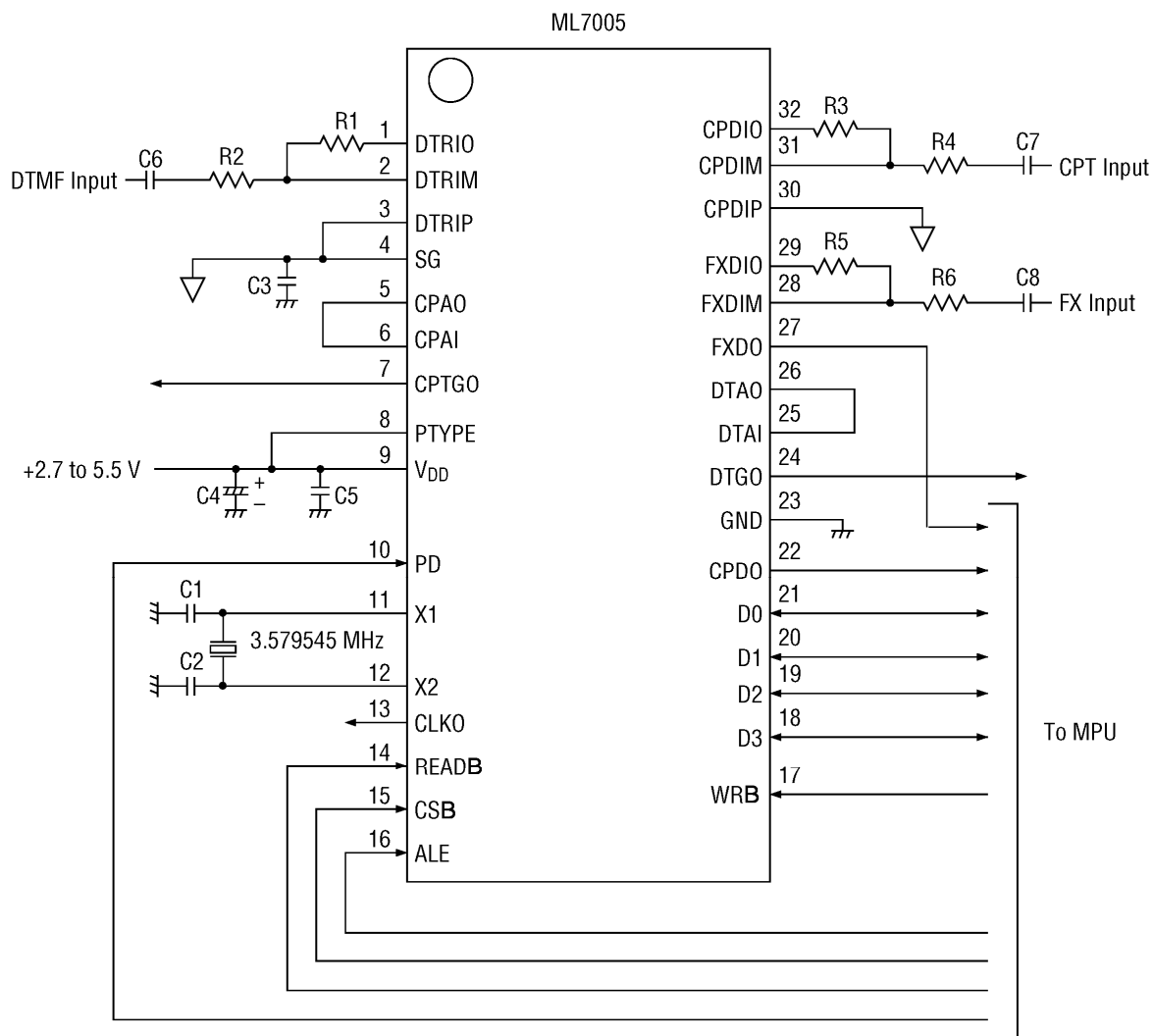

Note: ∇ indicates connection to the SG pin.

PACKAGE DIMENSIONS

(Unit: mm)

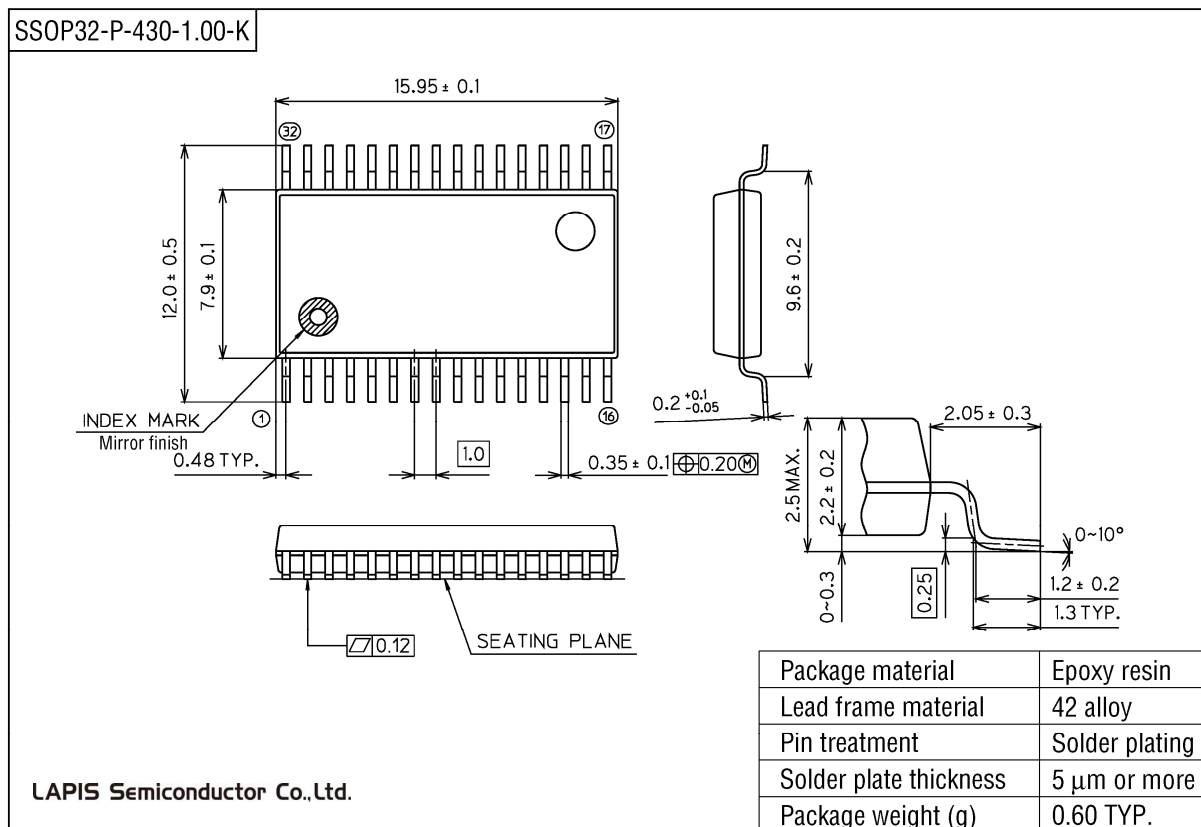

Notes for Mounting the Surface Mount Type Package

The surface mount type packages are very susceptible to heat in reflow mounting and humidity absorbed in storage.

Therefore, before you perform reflow mounting, contact ROHM's responsible sales person for the product name, package name, pin number, package code, and desired mounting conditions (reflow method, temperature and times).

REVISION HISTORY

Document No.	Date	Page		Description
		Previous Edition	Current Edition	
FEDL7005-01	2011.10.18	—	—	Issue of the LAPIS Semiconductor revision

NOTICE

No copying or reproduction of this document, in part or in whole, is permitted without the consent of LAPIS Semiconductor Co., Ltd.

The content specified herein is subject to change for improvement without notice.

The content specified herein is for the purpose of introducing LAPIS Semiconductor's products (hereinafter "Products"). If you wish to use any such Product, please be sure to refer to the specifications, which can be obtained from LAPIS Semiconductor upon request.

Examples of application circuits, circuit constants and any other information contained herein illustrate the standard usage and operations of the Products. The peripheral conditions must be taken into account when designing circuits for mass production.

Great care was taken in ensuring the accuracy of the information specified in this document. However, should you incur any damage arising from any inaccuracy or misprint of such information, LAPIS Semiconductor shall bear no responsibility for such damage.

The technical information specified herein is intended only to show the typical functions of and examples of application circuits for the Products. LAPIS Semiconductor does not grant you, explicitly or implicitly, any license to use or exercise intellectual property or other rights held by LAPIS Semiconductor and other parties. LAPIS Semiconductor shall bear no responsibility whatsoever for any dispute arising from the use of such technical information.

The Products specified in this document are intended to be used with general-use electronic equipment or devices (such as audio visual equipment, office-automation equipment, communication devices, electronic appliances and amusement devices).

The Products specified in this document are not designed to be radiation tolerant.

While LAPIS Semiconductor always makes efforts to enhance the quality and reliability of its Products, a Product may fail or malfunction for a variety of reasons.

Please be sure to implement in your equipment using the Products safety measures to guard against the possibility of physical injury, fire or any other damage caused in the event of the failure of any Product, such as derating, redundancy, fire control and fail-safe designs. LAPIS Semiconductor shall bear no responsibility whatsoever for your use of any Product outside of the prescribed scope or not in accordance with the instruction manual.

The Products are not designed or manufactured to be used with any equipment, device or system which requires an extremely high level of reliability the failure or malfunction of which may result in a direct threat to human life or create a risk of human injury (such as a medical instrument, transportation equipment, aerospace machinery, nuclear-reactor controller, fuel-controller or other safety device). LAPIS Semiconductor shall bear no responsibility in any way for use of any of the Products for the above special purposes. If a Product is intended to be used for any such special purpose, please contact a ROHM sales representative before purchasing.

If you intend to export or ship overseas any Product or technology specified herein that may be controlled under the Foreign Exchange and the Foreign Trade Law, you will be required to obtain a license or permit under the Law.