

---

# ML610Q347/ML610347

---

## 8-bit Microcontroller with Voice Output Function

---

### GENERAL DESCRIPTION

Equipped with an LAPIS Semiconductor original 8-bit CPU nX-U8/100, the ML610Q347/ML610347 is a high-performance 8-bit CMOS microcontroller that integrates a wide variety of peripherals such as an 12-bit A/D converter, timer, synchronous serial port, UART, and voice output function. The nX-U8/100 CPU is capable of executing instructions efficiently on a one-instruction-per-clock-pulse basis through parallel processing by the 3-stage pipelined architecture. The microcontroller is also equipped with a flash memory that has achieved low voltage and low power consumption (at read) equivalent to mask ROMs, so it is best suited to battery-driven applications such as cellular phones. In addition, it has an on-chip debugging function, which allows software debugging/rewriting with the LSI mounted on the board.

### FEATURES

- CPU
  - 8-bit RISC CPU (CPU name: nX-U8/100)
  - Instruction repertoire: 16-bit length instructions
  - Instruction set: Transfer, arithmetic operations, comparison, logical operations, multiply/divide operations, bit manipulation, bit logical operations, jump, conditional jump, call return stack manipulation, and arithmetic shift instructions.
  - Built-in on-chip debugging function
  - Minimum instruction execution time:
    - 31.25  $\mu$ s (@ 32kHz system clock)
    - 0.244  $\mu$ s (@ 4.096 MHz system clock)
- Internal memory
  - ML610Q347
    - Has 128-Kbyte flash memory (64K  $\times$  16-bit) built in. (including unusable 1KByte TEST area)
  - ML610347
    - Has 128-Kbyte mask memory (64K  $\times$  16-bit) built in. (including unusable 1KByte TEST area)
    - Has 1-Kbyte RAM (1024  $\times$  8-bit) built in.
- Interrupt controller
  - Non-maskable interrupt: 2 sources (1 internal source and 1 external sources)
  - Maskable interrupt: 18 sources (10 internal sources and 8 external sources)
- Time-base counter
  - Low-speed side time-base counter  $\times$  1ch
  - High-speed side time-base counter  $\times$  1ch
- Watchdog timer
  - Generates a non-maskable interrupt upon the first overflow and a system reset occurs upon the second
  - Free-running
  - Selectable overflow period: 4 types (125 ms, 500 ms, 2 sec, 8 sec)
- Timer
  - 8-bit  $\times$  2ch (16-bit configuration also enabled)

- Voice output function
  - Voice synthesis method: HQ-ADPCM / 4-bit ADPCM2 / 8-bit non-linear PCM / 8-bit PCM / 16-bit PCM
  - Sampling frequency: 6.4/8/10.7/12.8/16/21.3/25.6/32 kHz
- Speaker amplifier output power
  - 1W(at 5V)
- Synchronous serial port
  - Master/slave selectable
  - LSB/MSB-first selectable
  - 8-bit/16-bit length selectable
- UART
  - Half-Duplex Communication
  - TXD/RXD × 1 channel
  - Bit length, with/without parity, odd/even parity, 1 or 2 stop bits
  - Positive/negative logic selectable
  - Built-in baud-rate generator
- Successive-approximation type A/D converter
  - 12-bit A/D converter
  - Input: 12ch
  - Conversion time: 26.86  $\mu$ s per channel at 4.096 MHz
- General-purpose port
  - Input-only port × 8ch
  - Output-only port × 4ch (those as secondary functions are also included)
  - Input-output port × 16ch (those as secondary functions are also included)
- Reset
  - Resetting by the RESET\_N pin
  - Resetting upon power-on detection
  - Resetting upon WDT overflow detection
- Clock
  - Low-speed side clock
    - Built-in RC oscillator (32 kHz)
  - High-speed side clock
    - Crystal/ceramic oscillation (4.096 MHz), external clock
- Power management
  - HALT mode: Halts the execution of instructions issued by the CPU (the peripheral circuits continue operating)
  - STOP mode: Stops low-speed and high-speed oscillation (the CPU and the peripheral circuits stop operating)
  - Clock gear: Allows changing the frequency of the high-speed system clock by software (oscillator clock divided by 1, 2, 4, or 8)
  - Block Control Function: Power down (reset registers and stop clock supply) the circuits of unused peripherals.

- Shipment
  - 64-pin TQFP
  - High-speed side clock : Crystal/ceramic oscillation (4.096 MHz)
    - Flash Memory : ML610Q347-xxxTB (blank product: ML610Q347-NNNTB)
    - Mask Memory : ML610347-xxxTB
  
  - High-speed side clock : external clock
    - Flash Memory : ML610Q347J-xxxTB (blank product: ML610Q347J-NNNTB)
    - Mask Memory : ML610347J-xxxTB
  
  - xxx: ROM code number
  
- Guaranteed operating range
  - Operating temperature:  $-40^{\circ}\text{C}$  to  $+85^{\circ}\text{C}$
  - Operating voltage:  $V_{\text{DD}} = 2.2$  to  $5.5$  V,  $SPV_{\text{DD}} = 2.3$  to  $5.5$  V,  $AV_{\text{DD}} = 2.2$  to  $5.5$  V  
(Be sure to apply the same voltage to  $V_{\text{DD}}$  and  $SPV_{\text{DD}}$  power supplies.)

**BLOCK DIAGRAM**

Figure 1 is a block diagram of the ML610Q347.

Symbols with an asterisk “\*” indicate that each of them is the secondary or tertiary function of the corresponding port.

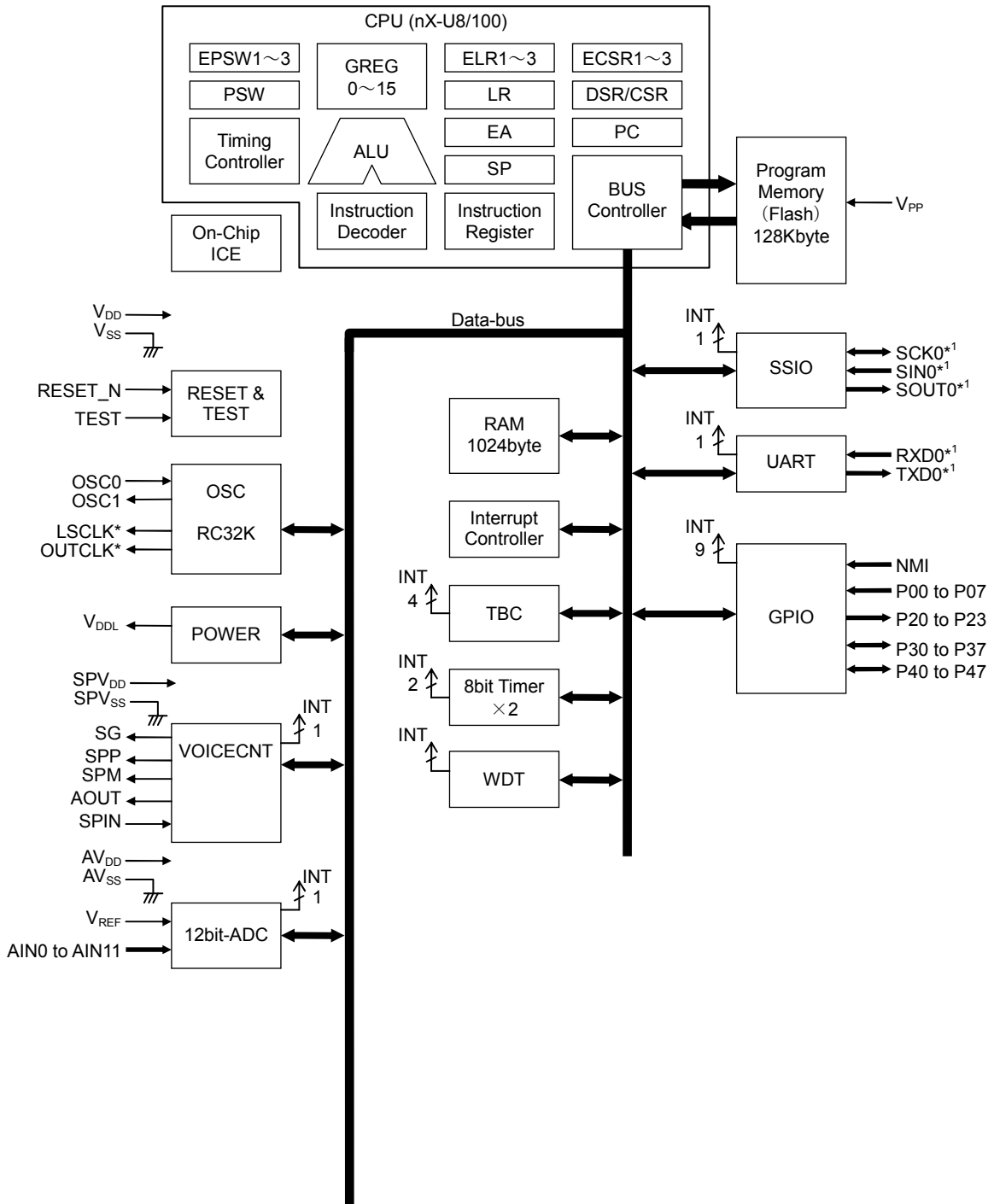

**Figure 1 Block Diagram of ML610Q347**

Figure 2 is a block diagram of the ML610347.

Symbols with an asterisk "\*" indicate that each of them is the secondary or tertiary function of the corresponding port.

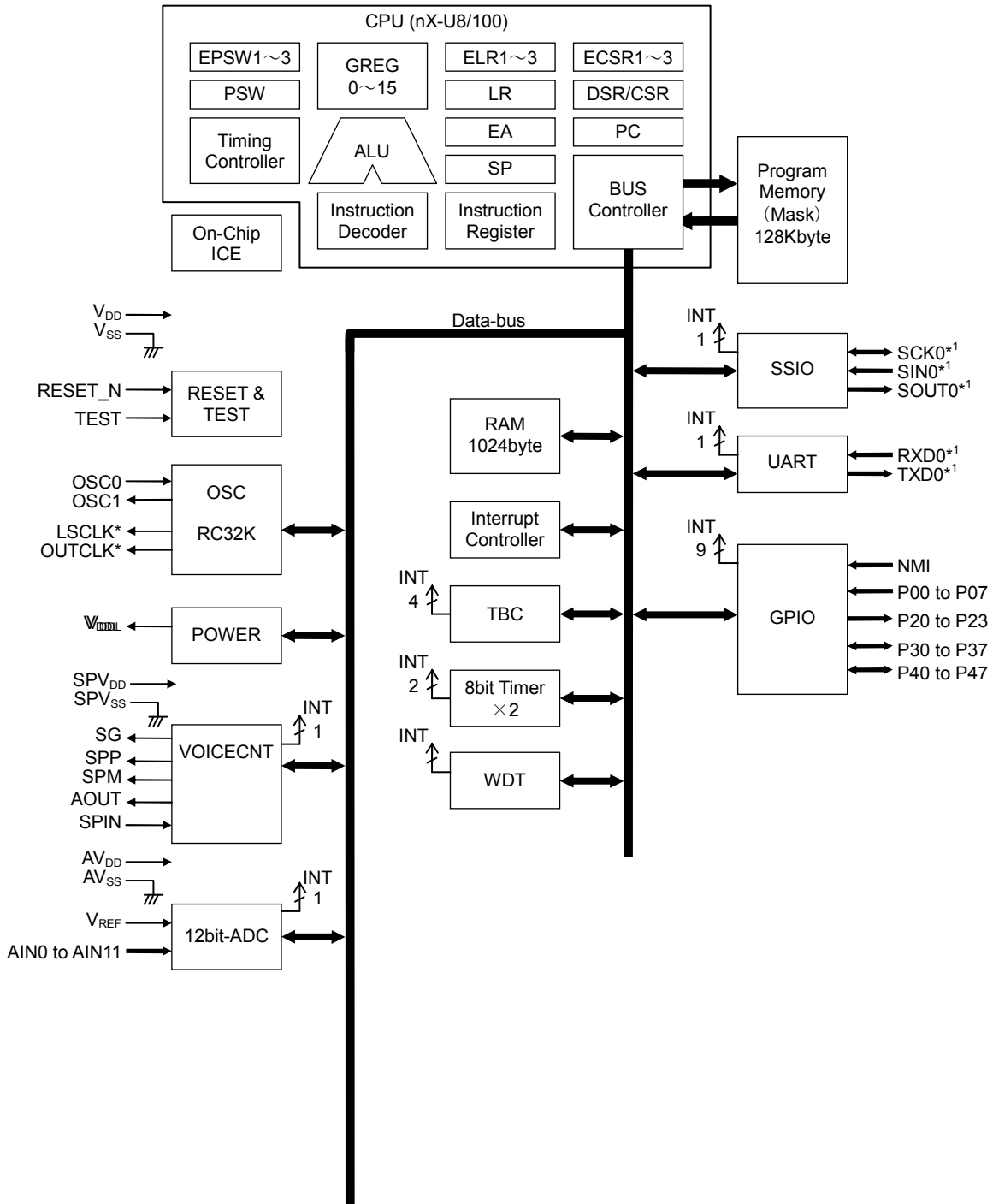

**Figure 2 Block Diagram of ML610347**



**ML610347 TQFP package product**

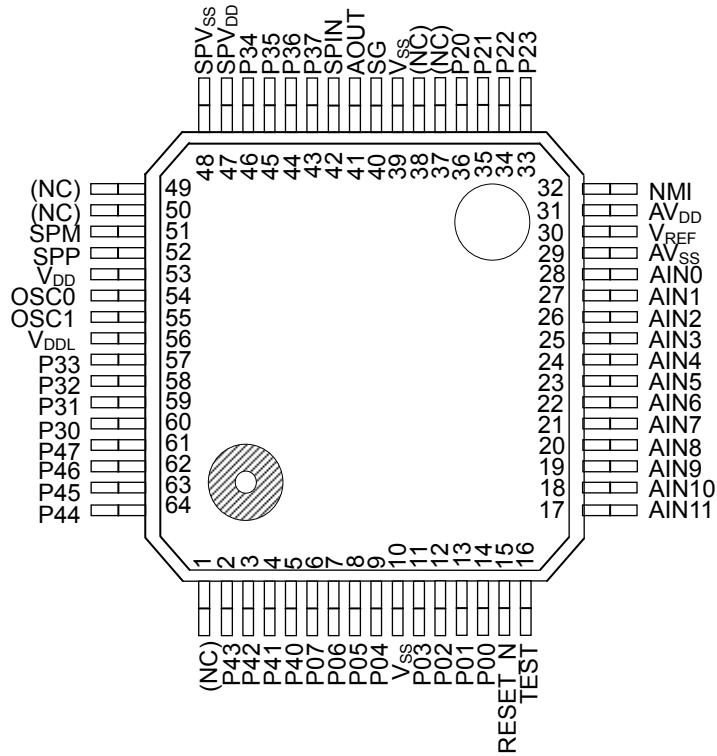

NC: No Connection

**Figure 4 Pin Configuration of ML610347 Package Product**

**LIST OF PINS**

PAD No	Primary function			Secondary function			Tertiary function		
	Pin name	I/O	Description	Pin name	I/O	Description	Pin name	I/O	Description
10,39	V <sub>SS</sub>	—	Negative power supply pin	—	—	—	—	—	—
53	V <sub>DD</sub>	—	Positive power supply pin	—	—	—	—	—	—
56	V <sub>DDL</sub>	—	Power supply for internal logic (internally generated)	—	—	—	—	—	—
48	SPV <sub>SS</sub>	—	Negative power supply pin for built-in speaker amplifier	—	—	—	—	—	—
47	SPV <sub>DD</sub>	—	Positive power supply pin for built-in speaker amplifier	—	—	—	—	—	—
29	AV <sub>SS</sub>	—	Negative power supply pin for successive-approximation type ADC	—	—	—	—	—	—
31	AV <sub>DD</sub>	—	Positive power supply pin for successive-approximation type ADC	—	—	—	—	—	—
1	V <sub>PP</sub> (*)	—	Power supply pin for flash memory	—	—	—	—	—	—
16	TEST	I/O	Input/output pin for testing	—	—	—	—	—	—
15	RESET_N	I	Reset input pin	—	—	—	—	—	—
54	OSC0	I	Connection pin for high-speed clock oscillation	—	—	—	—	—	—
55	OSC1	O	Connection pin for high-speed clock oscillation	P11	I	Input port	—	—	—
41	AOUT	O	LINE output	—	—	—	—	—	—
42	SPIN	I	Analog input to the built-in speaker amplifier	—	—	—	—	—	—
40	SG	O	Reference power supply pin of the built-in speaker amplifier	—	—	—	—	—	—
52	SPP	O	Positive output pin of the built-in speaker amplifier	—	—	—	—	—	—
51	SPM	O	Negative output pin of the built-in speaker amplifier	—	—	—	—	—	—
30	V <sub>REF</sub>	—	Reference power supply pin for successive-approximation type ADC	—	—	—	—	—	—
28	AIN0	I	Successive-approximation type ADC input	—	—	—	—	—	—
27	AIN1	I	Successive-approximation type ADC input	—	—	—	—	—	—
26	AIN2	I	Successive-approximation type ADC input	—	—	—	—	—	—
25	AIN3	I	Successive-approximation type ADC input	—	—	—	—	—	—

PAD No	Primary function			Secondary function			Tertiary function		
	Pin name	I/O	Description	Pin name	I/O	Description	Pin name	I/O	Description
24	AIN4	I	Successive-approximation type ADC input						
23	AIN5	I	Successive-approximation type ADC input						
22	AIN6	I	Successive-approximation type ADC input						
21	AIN7	I	Successive-approximation type ADC input						
20	AIN8	I	Successive-approximation type ADC input						
19	AIN9	I	Successive-approximation type ADC input						
18	AIN10	I	Successive-approximation type ADC input						
17	AIN11	I	Successive-approximation type ADC input						
32	NMI	I	Input port, non-maskable interrupt	—	—	—	—	—	—
14	P00/EXI0	I	Input port / External interrupt	—	—	—	—	—	—
13	P01/EXI1	I	Input port / External interrupt	—	—	—	—	—	—
12	P02/EXI2/RXD0	I	Input port / External interrupt / UART0 data input	—	—	—	—	—	—
11	P03/EXI3	I	Input port / External interrupt	—	—	—	—	—	—
9	P04/EXI4/T0P0CK	I	Input port / External interrupt / Timer 0 external clock input	—	—	—	—	—	—
8	P05/EXI5/T1P1CK	I	Input port / External interrupt / Timer 1 external clock input	—	—	—	—	—	—
7	P06/EXI6	I	Input port / External interrupt	—	—	—	—	—	—
6	P07/EXI7	I	Input port / External interrupt	—	—	—	—	—	—
36	P20/LED0	O	Output port / LED drive	LSCLK	O	Low-speed clock output	—	—	—
35	P21/LED1	O	Output port / LED drive	OUTCLK	O	high-speed clock output	—	—	—
34	P22/LED2	O	Output port / LED drive	—	—	—	—	—	—
33	P23/LED3	O	Output port / LED drive	—	—	—	—	—	—
60	P30	I/O	Input/output port	—	—	—	—	—	—
59	P31	I/O	Input/output port	—	—	—	—	—	—
58	P32	I/O	Input/output port	—	—	—	—	—	—
57	P33	I/O	Input/output port	—	—	—	—	—	—
46	P34	I/O	Input/output port	—	—	—	—	—	—
45	P35	I/O	Input/output port	—	—	—	—	—	—
44	P36	I/O	Input/output port	LSCLK	O	Low-speed clock output	—	—	—
43	P37	I/O	Input/output port	OUTCLK	O	high-speed clock output	—	—	—
5	P40	I/O	Input/output port	—	—	—	SIN0	I	SSIO0 data input
4	P41	I/O	Input/output port	—	—	—	SCK0	I/O	SSIO0 synchronous

PAD No	Primary function			Secondary function			Tertiary function		
	Pin name	I/O	Description	Pin name	I/O	Description	Pin name	I/O	Description
									clock input/output
3	P42	I/O	Input/output port	RXD0	I	UART0 data input	SOUT0	O	SSIO0 data output
2	P43	I/O	Input/output port	TXD0	O	UART0 data output	—	—	—
64	P44/T0P0 CK	I/O	Input/output port, Timer 0 external clock input	—	—	—	SIN0	I	SSIO0 data input
63	P45/T1P1 CK	I/O	Input/output port, Timer 1 external clock input	—	—	—	SCK0	I/O	SSIO0 synchronous clock input/output
62	P46	I/O	Input/output port	—	—	—	SOUT0	O	SSIO0 data output
61	P47	I/O	Input/output port	—	—	—	—	—	—

\*: Applies to the ML610Q347.

**PIN DESCRIPTION**

Pin name	I/O	Description	Primary/ Secondary/ Tertiary	Logic
<b>Power supply</b>				
V <sub>SS</sub>	—	Negative power supply pin	—	—
V <sub>DD</sub>	—	Positive power supply pin	—	—
V <sub>DDL</sub>	—	Positive power supply pin for internal logic (internally generated) Capacitors C <sub>L</sub> (see measuring circuit 1) are connected between this pin and V <sub>SS</sub> .	—	—
SPV <sub>SS</sub>	—	Negative power supply pin for built-in speaker amplifier	—	—
SPV <sub>DD</sub>	—	Positive power supply pin for built-in speaker amplifier	—	—
AV <sub>SS</sub>	—	Negative power supply pin for successive-approximation type ADC	—	—
AV <sub>DD</sub>	—	Positive power supply pin for successive-approximation type ADC	—	—
V <sub>PP</sub> (*)	—	Power supply pin for flash memory	—	—
<b>Test</b>				
TEST	I/O	Input/output pin for testing. Has a pull-down resistor built in.	—	Positive
<b>System</b>				
RESET_N	I	Reset input pin. When this pin is set to a “L” level, the device is placed in system reset mode and the internal circuit is initialized. If after that this pin is set to a “H” level, program execution starts. This pin has a pull-up resistor built in.	—	Negative
OSC0	I	Pins for connecting a crystal unit for high speed clock.	—	—
OSC1	O	Connect a 4.096 MHz crystal unit (see Measuring Circuit 1) to these pins. Also, connect capacitors (C <sub>DH</sub> and C <sub>GH</sub> ) between these pins and V <sub>SS</sub> as required.	—	—
LSCLK	O	Low-speed clock output. This function is allocated to the secondary function of the P20 and P36 pins.	Secondary	—
OUTCLK	O	High-speed clock output. This function is allocated to the secondary function of the P21 and P37 pins.	Secondary	—
<b>General-purpose Input port</b>				
P00–P07	I	General-purpose input ports.	Primary	Positive
<b>General-purpose Output port</b>				
P20–P23	O	General-purpose output ports. Provided with a secondary function. Cannot be used as ports if their secondary function is used.	Primary	Positive
<b>General-purpose Input/output port</b>				
P30–P37	I/O	General-purpose input/output ports.	Primary	Positive
P40–P47	I/O	Provided with a secondary function. Cannot be used as ports if their secondary function is used.		

\*Applies to the ML610Q347.

Pin name	I/O	Description	Primary/ Secondary/ Tertiary	Logic
<b>UART</b>				
TXD0	O	UART0 data output pin. Allocated to the secondary function of the P43 pin.	Secondary	Positive
RXD0	I	UART0 data input pin. Allocated to the primary function of the P02 pin and the secondary function of the P42 pin.	Secondary	Positive
<b>Synchronous serial (SSIO)</b>				
SIN0	I	Synchronous serial data input pin. Allocated to the tertiary function of the P40 pin and P44 pins.	Tertiary	Positive
SCK0	I/O	Synchronous serial clock input/output pin. Allocated to the tertiary function of the P41 and P45 pins.	Tertiary	—
SOUT0	O	Synchronous serial data output pin. Allocated to the tertiary function of the P42 and P46 pins.	Tertiary	Positive
<b>External interrupt</b>				
NMI	I	External non-maskable interrupt input pin. The interrupt occurs on both the rising and falling edges.	Primary	Positive/ Negative
EXI0–7	I	External maskable interrupt input pins. It is possible, for each bit, to specify whether the interrupt is enabled and select the interrupt edge by software. Allocated to the primary function of the P00–P07 pins.	Primary	Positive/ Negative
<b>Timer</b>				
T0P0CK	I	External clock input pin for timer 0. Allocated to the primary function of the P04 and P44 pins.	Primary	—
T1P1CK	I	External clock input pin for timer 1. Allocated to the primary function of the P05 and P45 pins.	Primary	—
<b>LED drive</b>				
LED0–3	O	NMOS open drain pins to allow direct driving of LED. Allocated to the secondary function of the P20–P22 pins.	Primary	Positive/ Negative
<b>Voice output function</b>				
AOUT	O	LINE output pin. When you use built-in speaker amplifier, connect with the SPIN pin.	—	—
SPIN	I	Analog input pin of the internal speaker amplifier.	—	—
SG	O	Reference voltage output pin of the internal speaker amplifier.	—	—
SPP	O	Positive output pin of the internal speaker amplifier.	—	—
SPM	O	Negative output pin of the internal speaker amplifier.	—	—
<b>Successive-approximation type A/D converter</b>				
V <sub>REF</sub>	—	Reference power supply pin for the successive-approximation type A/D converter.	—	—
AIN0–AIN11	I	Analog inputs to Ch0 to Ch11 of the successive-approximation type A/D converter.	—	—

## ELECTRICAL CHARACTERISTICS

### Absolute Maximum Ratings

(V<sub>SS</sub> = AV<sub>SS</sub> = SPV<sub>SS</sub> = 0V)

Parameter	Symbol	Condition	Rating	Unit
Power supply voltage 1	V <sub>DD</sub>	Ta = 25°C	-0.3 to +7.0	V
Power supply voltage 2	AV <sub>DD</sub>	Ta = 25°C	-0.3 to +7.0	V
Power supply voltage 3	SPV <sub>DD</sub>	Ta = 25°C	-0.3 to +7.0	V
Power supply voltage 4	V <sub>DDL</sub>	Ta = 25°C	-0.3 to +3.6	V
Power supply voltage 5	V <sub>PP</sub>	Ta = 25°C	-0.3 to +9.5	V
Input voltage	V <sub>IN</sub>	Ta = 25°C	-0.3 to V <sub>DD</sub> +0.3	V
Output voltage	V <sub>OUT</sub>	Ta = 25°C	-0.3 to V <sub>DD</sub> +0.3	V
Output current 1	I <sub>OUT1</sub>	P03, P04, Ta = 25°C	-12 to +11	mA
Output current 2	I <sub>OUT2</sub>	P02, Ta = 25°C	-12 to +20	mA
Power dissipation	PD	Ta = 25°C	861	mW
Storage temperature	T <sub>STG</sub>	—	-55 to +150	°C

### Recommended Operating Conditions

(V<sub>SS</sub> = AV<sub>SS</sub> = SPV<sub>SS</sub> = 0V)

Parameter	Symbol	Condition	Range	Unit
Operating temperature	T <sub>OP</sub>	—	-40 to +85	°C
Operating voltage	V <sub>DD</sub>	—	2.2 to 5.5	V
	SPV <sub>DD</sub>	—	2.3 to 5.5	
	AV <sub>DD</sub>	—	2.2 to 5.5	
Operating frequency (CPU)	f <sub>OP</sub>	—	27k to 4.2M	Hz
High-speed crystal/ceramic oscillation frequency	f <sub>XTH</sub>	—	4.0M, 4.096M	Hz
High-speed crystal oscillation external capacitor	C <sub>DH</sub>	—	15 to 32	pF
	C <sub>GH</sub>	—	15 to 32	
Capacitor externally connected to V <sub>DDL</sub> pin	C <sub>L</sub>	—	10±30%	μF
Capacitor externally connected to SG pin	C <sub>SG</sub>	—	0.1±30%	μF

**Flash Memory Operating Conditions**

( $V_{SS} = AV_{SS} = SPV_{SS} = 0V$ )

Parameter	Symbol	Condition	Range	Unit
Operating temperature	$T_{OP}$	At write/erase	0 to +40	°C
Operating voltage	$V_{DD}$	At write/erase (*1)	2.7 to 3.6	V
	$V_{DDL}$	At write/erase (*1)	2.5 to 2.75	
	$V_{PP}$	At write/erase (*1)	7.7 to 8.3	
Maximum rewrite count	$C_{EP}$	—	80	times
Data retention period	$Y_{DR}$	—	10	years

\*1: When writing data to, or erasing data from, flash ROM, it is necessary to apply a voltage within the range specified above to the  $V_{DDL}$  pin.

**DC Characteristics (1 of 5)**

( $V_{DD} = SPV_{DD} = AV_{DD} = 2.2$  to  $5.5V$ ,  $V_{SS} = AV_{SS} = SPV_{SS} = 0V$ ,  
 $T_a = -40$  to  $+85^{\circ}C$ , unless otherwise specified)

Parameter	Symbol	Condition	Min.	Typ.	Max.	Unit	Measuring circuit
High-speed oscillation start time	$T_{XTH}$	—	—	2	20	ms	1
Low-speed RC oscillator frequency	$f_{LCR}$	—	27.2k	32k	36.8k	Hz	
Reset pulse width	$P_{RST}$	—	100	—	—	μs	
Reset noise rejection pulse width	$P_{NRST}$	—	—	—	0.4		
Time from power-on reset to power-up	$T_{POR}$	—	—	—	10	ms	

**DC Characteristics (2 of 5)**

( $V_{DD} = SPV_{DD} = 2.3$  to  $5.5V$ ,  $AV_{DD} = 2.2$  to  $5.5V$ ,  $V_{SS} = AV_{SS} = SPV_{SS} = 0V$ ,  
 $T_a = -40$  to  $+85^{\circ}C$ , unless otherwise specified)

Parameter	Symbol	Condition	Min.	Typ.	Max.	Unit	Measuring circuit
LINE amplifier output load resistance	$R_{LA}$	At $1/2V_{DD}$ output	10	—	—	$k\Omega$	1
LINE amplifier output voltage range	$V_{AD}$	At output load	$DV_{DD} \times 1/6$	—	$DV_{DD} \times 5/6$	V	
SG output voltage	$V_{SG}$	—	$0.95 \times DV_{DD}/2$	$DV_{DD}/2$	$1.05 \times DV_{DD}/2$	V	
SG output resistance	$R_{SG}$	—	57	96	135	$k\Omega$	
SPM, SPP output load resistance	$R_{LSP}$	—	8	—	—	$\Omega$	
Speaker amplifier output power	PSPO1	$SPV_{DD} = 3.3V$ , $f = 1kHz$ , $RSPO = 8\Omega$ , $THD \geq 10\%$ At SPIN Input	—	0.5	—	W	
	PSPO2	$SPV_{DD} = 5.0V$ , $f = 1kHz$ , $RSPO = 8\Omega$ , $THD \geq 10\%$ At SPIN Input	—	1	—	W	
Output offset voltage between SPM and SPP with no signal present	VOF	$SPV_{DD} = 3.0V$ , SPIN – SPM gain = +6dB With a load of $8\Omega$	-50	—	+50	mV	

**DC Characteristics (3 of 5) ML610Q347**

( $V_{DD} = SPV_{DD} = AV_{DD} = 2.2$  to  $5.5V$ ,  $V_{SS} = AV_{SS} = SPV_{SS} = 0V$ ,  
 $T_a = -40$  to  $+85^{\circ}C$ , unless otherwise specified)

Parameter	Symbol	Condition	Min.	Typ.	Max.	Unit	Measuring circuit	
Supply current 1	IDD1	CPU: In STOP state. Low-speed/high-speed oscillation: stopped	$T_a \leq +40^{\circ}C$	—	0.5	2.0	$\mu A$	1
			$T_a \leq +85^{\circ}C$	—	0.5	8		
Supply current 2	IDD2	CPU: In HALT state (LTBC: Operating <sup>*3</sup> ) High-speed oscillation: Stopped	$T_a \leq +40^{\circ}C$	—	1.5	3.0		
			$T_a \leq +85^{\circ}C$	—	1.5	10		
Supply current 3	IDD3	CPU: Running at 32 kHz <sup>*1</sup> High-speed oscillation: Stopped	—	10	35			
Supply current 4	IDD4	CPU: Running at 4.096MHz Crystal/ceramic oscillating mode <sup>*2</sup>	$V_{DD} = AV_{DD} = SPV_{DD} = 3.0V$	—	1.7	4		
			$V_{DD} = AV_{DD} = SPV_{DD} = 5.0V$	—	2.2	4		
Supply current 5	IDD5	CPU: Running at 4.096MHz Crystal/ceramic oscillating mode <sup>*2</sup> During voice playback (no output load)	$V_{DD} = AV_{DD} = SPV_{DD} = 3.0V$	—	3	12		
			$V_{DD} = AV_{DD} = SPV_{DD} = 5.0V$	—	8	12		
Supply current 6	IDD6	CPU: Running at 4.096MHz Crystal/ceramic oscillating mode <sup>*2</sup> ADC: Operating	$V_{DD} = AV_{DD} = SPV_{DD} = 3.0V$	—	1.9	5.5		
			$V_{DD} = AV_{DD} = SPV_{DD} = 5.0V$	—	3.2	5.5		

\*1: Case when the CPU operating rate is 100% (with no HALT state)

\*2: Use 4.096MHz Crystal Oscillator CHC49SFWB (Kyocera).

\*3: Significant bits of BLKCON0~BLKCON4 registers are all "1".

**DC Characteristics (3 of 5) ML610347**

( $V_{DD} = SPV_{DD} = AV_{DD} = 2.2$  to  $5.5V$ ,  $V_{SS} = AV_{SS} = SPV_{SS} = 0V$ ,  
 $T_a = -40$  to  $+85^{\circ}C$ , unless otherwise specified)

Parameter	Symbol	Condition	Min.	Typ.	Max.	Unit	Measuring circuit		
Supply current 1	IDD1	CPU: In STOP state. Low-speed/high-speed oscillation: stopped	$T_a \leq +40^{\circ}C$	—	0.5	2.0	$\mu A$	1	
			$T_a \leq +85^{\circ}C$	—	0.5	8			
Supply current 2	IDD2	CPU: In HALT state (LTBC: Operating <sup>*3</sup> ) High-speed oscillation: Stopped	$T_a \leq +40^{\circ}C$	—	1.2	3.0			
			$T_a \leq +85^{\circ}C$	—	1.2	10			
Supply current 3	IDD3	CPU: Running at 32 kHz <sup>*1</sup> High-speed oscillation: Stopped	—	5	35				
Supply current 4	IDD4	CPU: Running at 4.096MHz Crystal/ceramic oscillating mode <sup>*2</sup>	$V_{DD} = AV_{DD} = SPV_{DD} = 3.0V$	—	1	4			$mA$
			$V_{DD} = AV_{DD} = SPV_{DD} = 5.0V$	—	2	4			
Supply current 5	IDD5	CPU: Running at 4.096MHz Crystal/ceramic oscillating mode <sup>*2</sup> During voice playback (no output load)	$V_{DD} = AV_{DD} = SPV_{DD} = 3.0V$	—	2.8	12			
			$V_{DD} = AV_{DD} = SPV_{DD} = 5.0V$	—	8	12			
Supply current 6	IDD6	CPU: Running at 4.096MHz Crystal/ceramic oscillating mode <sup>*2</sup> ADC: Operating	$V_{DD} = AV_{DD} = SPV_{DD} = 3.0V$	—	1.1	5.5			
			$V_{DD} = AV_{DD} = SPV_{DD} = 5.0V$	—	2.3	5.5			

\*1: Case when the CPU operating rate is 100% (with no HALT state)

\*2: Use 4.096MHz Crystal Oscillator CHC49SFWB (Kyocera).

\*3: Significant bits of BLKCON0~BLKCON4 registers are all "1".

**PACKAGE DIMENSIONS**

(Unit: mm)

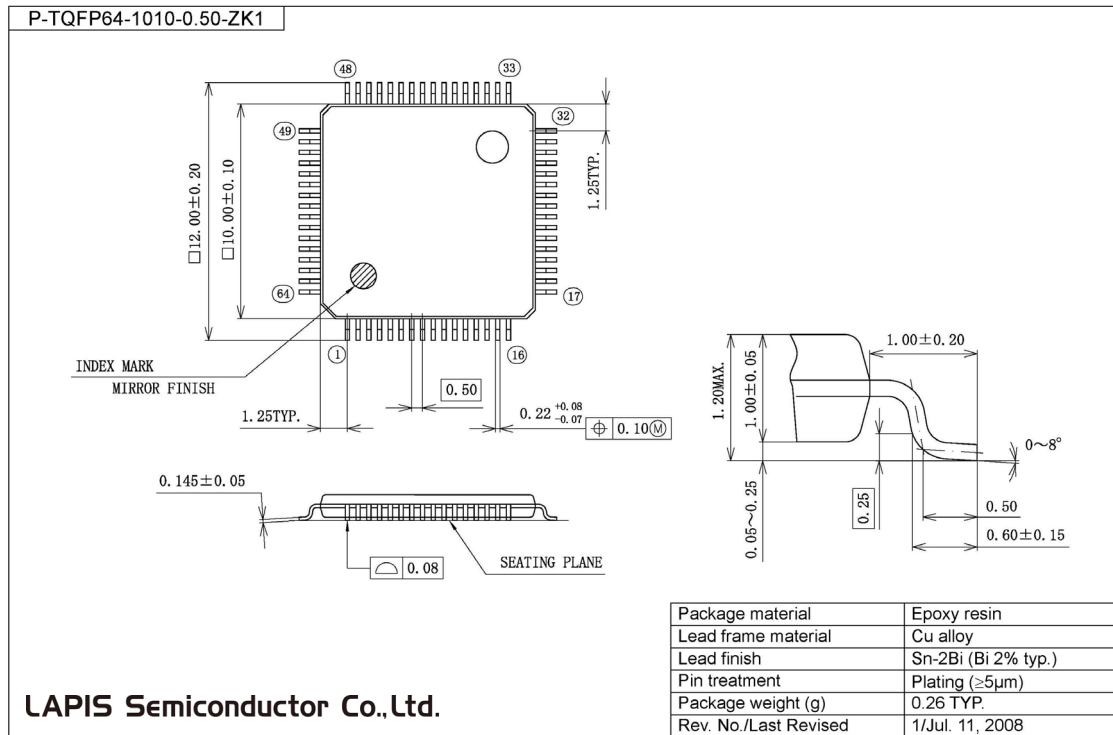

**NOTICE**

No copying or reproduction of this document, in part or in whole, is permitted without the consent of LAPIS Semiconductor Co., Ltd.

The content specified herein is subject to change for improvement without notice.

The content specified herein is for the purpose of introducing LAPIS Semiconductor's products (hereinafter "Products"). If you wish to use any such Product, please be sure to refer to the specifications, which can be obtained from LAPIS Semiconductor upon request.

Examples of application circuits, circuit constants and any other information contained herein illustrate the standard usage and operations of the Products. The peripheral conditions must be taken into account when designing circuits for mass production.

Great care was taken in ensuring the accuracy of the information specified in this document. However, should you incur any damage arising from any inaccuracy or misprint of such information, LAPIS Semiconductor shall bear no responsibility for such damage.

The technical information specified herein is intended only to show the typical functions of and examples of application circuits for the Products. LAPIS Semiconductor does not grant you, explicitly or implicitly, any license to use or exercise intellectual property or other rights held by LAPIS Semiconductor and other parties. LAPIS Semiconductor shall bear no responsibility whatsoever for any dispute arising from the use of such technical information.

The Products specified in this document are intended to be used with general-use electronic equipment or devices (such as audio visual equipment, office-automation equipment, communication devices, electronic appliances and amusement devices).

The Products specified in this document are not designed to be radiation tolerant.

While LAPIS Semiconductor always makes efforts to enhance the quality and reliability of its Products, a Product may fail or malfunction for a variety of reasons.

Please be sure to implement in your equipment using the Products safety measures to guard against the possibility of physical injury, fire or any other damage caused in the event of the failure of any Product, such as derating, redundancy, fire control and fail-safe designs. LAPIS Semiconductor shall bear no responsibility whatsoever for your use of any Product outside of the prescribed scope or not in accordance with the instruction manual.

The Products are not designed or manufactured to be used with any equipment, device or system which requires an extremely high level of reliability the failure or malfunction of which may result in a direct threat to human life or create a risk of human injury (such as a medical instrument, transportation equipment, aerospace machinery, nuclear-reactor controller, fuel-controller or other safety device). LAPIS Semiconductor shall bear no responsibility in any way for use of any of the Products for the above special purposes. If a Product is intended to be used for any such special purpose, please contact a ROHM sales representative before purchasing.

If you intend to export or ship overseas any Product or technology specified herein that may be controlled under the Foreign Exchange and the Foreign Trade Law, you will be required to obtain a license or permit under the Law.