MSM9563

IC for FM Multiplex Data Demodulation

GENERAL DESCRIPTION

The MSM9563 is an IC which demodulates FM character multiplex signals in the DARC (Data Radio Channel)*1 format to obtain digital data. The MSM9563 operates at 3 V.

The MSM9563 contains on one chip a band pass filter using a switched capacitor filter (SCF) and a group of circuits including frame memory, a frame synchronization circuit, and an error correction circuit.

By connecting an external FM receiver and memory for temporary data storage, and microcontroller, a system for obtaining digital data can easily be constructed.

The FM multiplex demodulation ICs, the MSM9500-series devices, are configured with minimum functions; so they will, by changing the software of the external microcontroller, be able to respond flexibly to the many FM multiplex broadcast services that are going to come about in the future.

The MSM9563 is best suited to radios and information processing devices that support DARC FM multiplex broadcasting. It is also best suited to car radios and car navigation systems.

*1 DARC is a registered trademark of NHK Engineering Services.

Note that a contract needs to be made with NHK Engineering Service if a manufacturer produces/sells electronic equipment utilizing the DARC technology.

FEATURES

- Built-in two receive channels including main channel and sub-channel (one of two FM stations can be selected)
- Pin compatible with MSM9553/MSM9555
- Internal frame memory enables automatic error correction.
- Built-in bandpass filter (SCF)
- Built-in block synchronization circuit and frame synchronization circuit
- Setting of the number of synchronization protection steps can be changed.
- Data clocks are regenerated by digital PLL.
- 1T delay detection
- Built-in vertical and horizontal error correction circuits
- Built-in layer 4 and layer 2 CRC processing circuits
- Parallel interface with microcontroller
- Clock output for external devices (64 kHz to 8.192 MHz variable)
- Compatible with the international standard frame formats A (real time block also supported), B, C
- Power supply: 2.7 V to 3.6 V
- Package:
44-pin plastic QFP (QFP44-P-910-0.80-2K) (Product name: MSM9563GA)

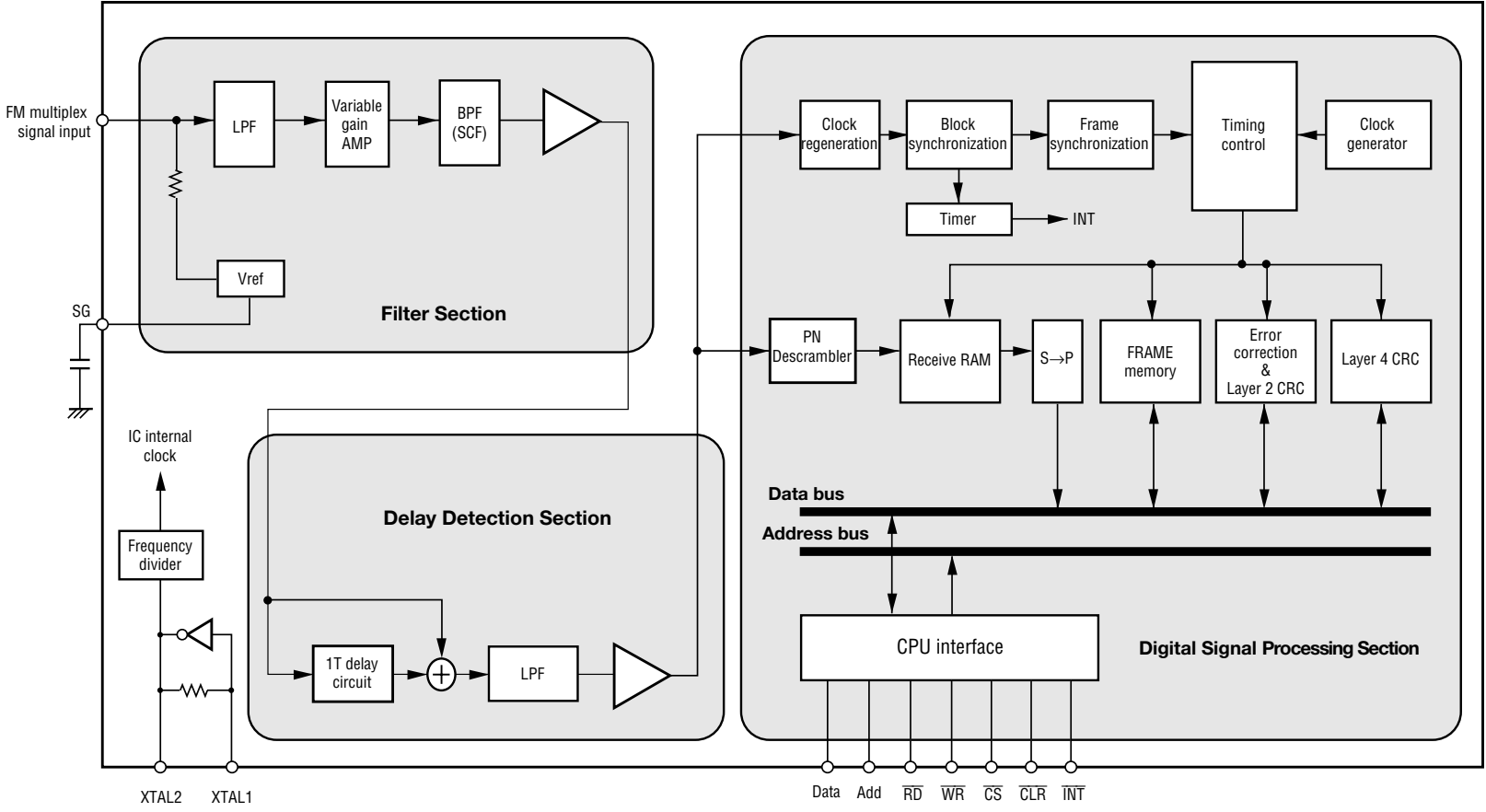

BLOCK DIAGRAM

PIN CONFIGURATION (TOP VIEW)

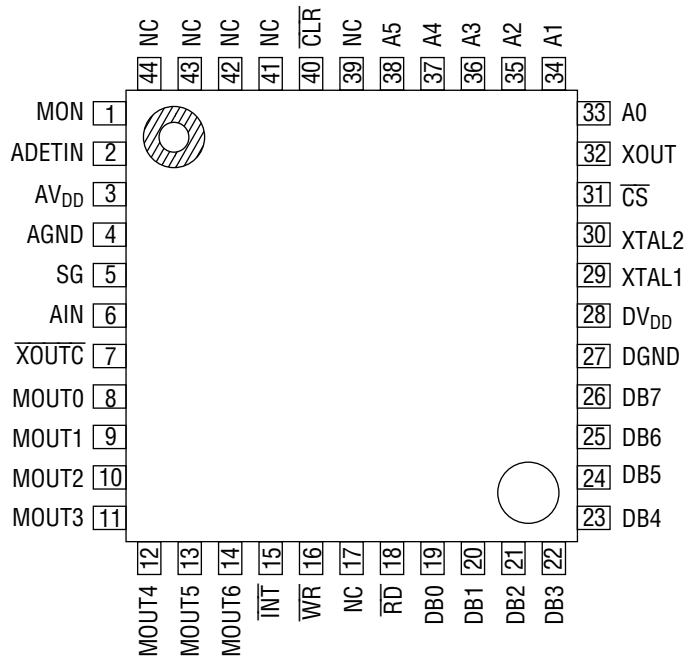

NC : No-connection pin

44-Pin Plastic QFP

PIN DESCRIPTIONS

Function	Pin	Symbol	Type	Description
Microcontroller Interface	16	\overline{WR}	I	Write signal to internal register.
	18	\overline{RD}	I	Read signal to internal register.
	15	\overline{INT}	O	Interrupt signal to microcontroller. "L": An interrupt is generated.
	31	\overline{CS}	I	Chip select signal. "L": Read, write, and data bus signals become active.
	40	\overline{CLR}	I	"L" : the internal registers are initialized and the device enters power down mode.
	33 to 38	A0 to A5	I	Address signal to internal register.
	19 to 26	DB0 to DB7	I/O	Data bus signal to internal register.
Tuner Interface	6	AIN	I	FM multiplex signal input.
	5	SG	O	Analog reference voltage output pin. Connect a capacitor between this pin and analog ground to prevent noise.
Analog Section Test	1	MON	O	Analog section waveform monitoring pin. The analog block mode setting is specified by the analog control register.
	2	ADETIN	I	Digital signal input pin for testing analog section.
Digital Section Test	8 to 14	MOUT0 to MOUT6	O	Digital section test signal output and monitor output pins.
Clock	29	XTAL1	I	8.192 MHz crystal connection pin.
	30	XTAL2	O	8.192 MHz crystal connection pin.
	32	XOUT	O	Pin for supply of 64 kHz to 8.192 MHz variable clock to the outside.
	7	\overline{XOUTC}	I	XOUT output control pin. "L" = Clock output, "H" = Output disabled. Pulled up internally.
Power Supply	3	AV _{DD}	—	Analog section power supply pin.
	4	AGND	—	Analog ground pin.
	28	DV _{DD}	—	Digital section power supply pin.
	27	DGND	—	Digital ground pin.

ABSOLUTE MAXIMUM RATINGS

Parameter	Symbol	Condition	Rating	Unit
Power Supply Voltage	AV_{DD}	$AV_{DD} = DV_{DD}$ $T_a = 25^{\circ}\text{C}$	-0.3 to +7.0	V
	DV_{DD}			
Input Voltage	V_I		-0.3 to $AV_{DD} + 0.3$	
Output Voltage	V_O	-0.3 to $DV_{DD} + 0.3$		
Maximum Power Dissipation	P_D	$T_a = 25^{\circ}\text{C}$, per package	400	mW
		$T_a = 25^{\circ}\text{C}$, per output	50	
Storage Temperature	T_{STG}	—	-55 to +150	$^{\circ}\text{C}$

RECOMMENDED OPERATING CONDITIONS

Parameter	Symbol	Condition	Range	Unit	Applied Pin
Power Supply Voltage	AV_{DD}	$AV_{DD} = DV_{DD}$	2.7 to 3.6	V	AV_{DD}
	DV_{DD}				DV_{DD}
Crystal Oscillation Frequency	f_{XTAL}	—	8.192 MHz \pm 100 ppm	—	XTAL1, XTAL2
FM Multiplex Signal Input Voltage	V_{AIN}^*	Variable amplifier gain: $\times 1$	0.6 to 0.9	V_{P-P}	AIN
		Variable amplifier gain: $\times 1.5$	0.4 to 0.6		
		Variable amplifier gain: $\times 2$	0.3 to 0.4		
		Variable amplifier gain: $\times 3$	0.2 to 0.3		
Operating Temperature	T_{op}	—	-40 to +85	$^{\circ}\text{C}$	—

* Peak values (a total voltage of the following signals (a) to (c)) of composite signals including multiplex signals.

- (a) Voice signals (100% modulated: voice max.)
- (b) Pilot signal
- (c) FM multiplex signals (10%: LMSK max.)

The maximum amplitude of an input signal is in the range of $0.9 V_{P-P}$ in which the internal IC circuit is not saturated.

Therefore, multiplex signals of up to $0.9 V_{P-P}$ can be input if only multiplex signals (excluding composite signals) are input from a signal generator.

ELECTRICAL CHARACTERISTICS(DV_{DD} = AV_{DD} = 2.7 to 3.6 V, DGND = AGND = 0 V, Ta = -40 to +85°C)

Parameter	Symbol	Condition	Min.	Typ.	Max.	Unit	Applied Pin
Supply Current	I _{DD}	When operating, no load f = 8.192 MHz	—	14	28	mA	AV _{DD} , DV _{DD}
		When in power down mode, no load	—	—	50	μA	
BPF Pass Band Attenuation	GAIN1	72 to 80 kHz Variable gain amplifier gain: 0 dB	—	—	3.0	dB	MON
BPF Stop Band Attenuation	GAIN2	0 to 53 kHz Variable gain amplifier gain: 0 dB	50	—	—	dB	MON
BPF Stop Band Attenuation	GAIN3	100 to 500 kHz Variable gain amplifier gain: 0 dB	50	—	—	dB	MON

EXTERNAL CONNECTION EXAMPLE

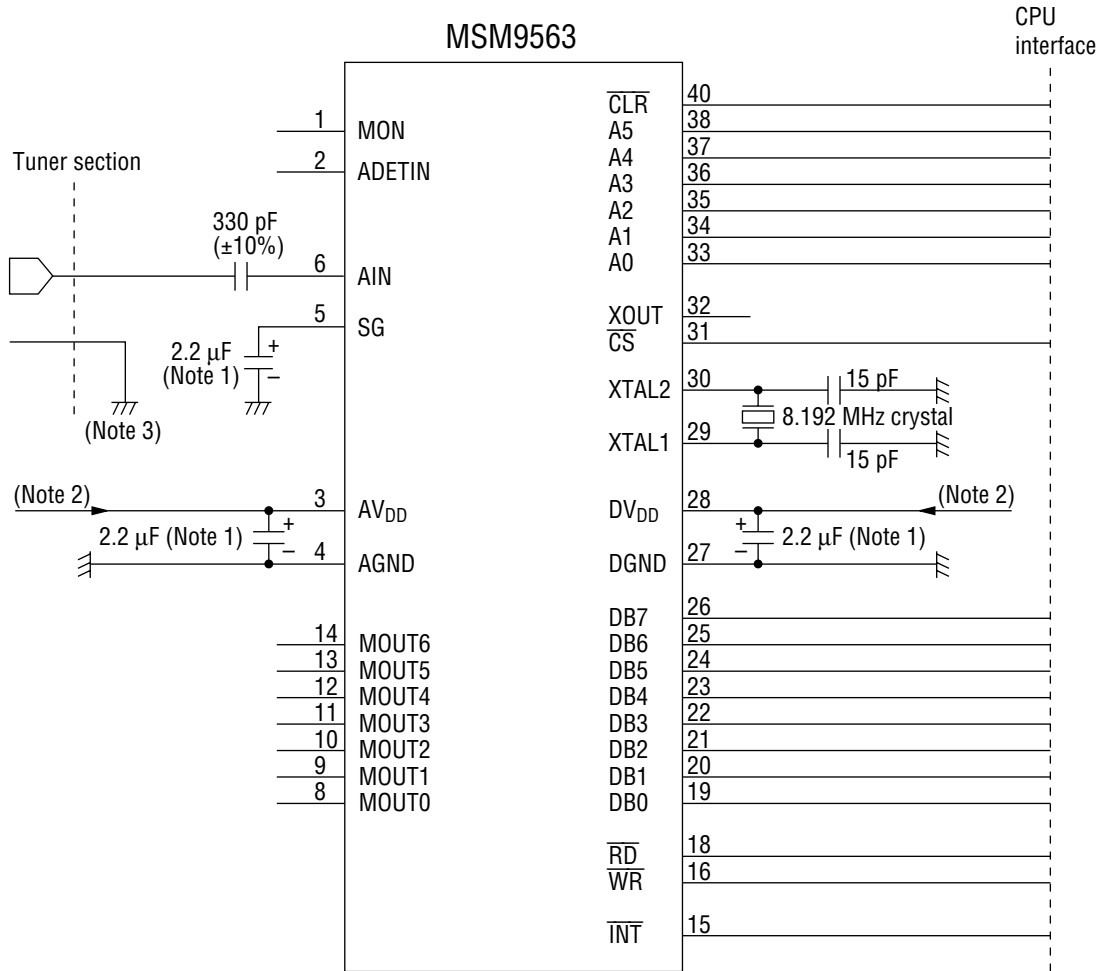

(Note 1) Use a tantalum capacitor.

(Note 2) The AV_{DD} and DV_{DD} should have different paths, respectively.

(Note 3) The AGND and tuner ground should use the same ground.

APPLICATION CIRCUIT EXAMPLE

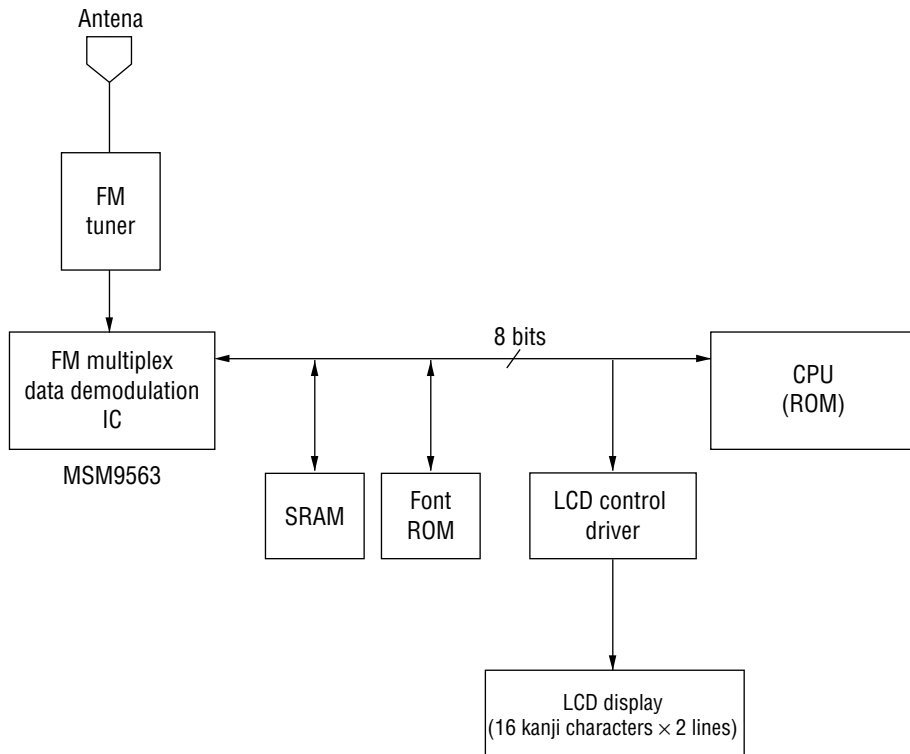

PACKAGE DIMENSIONS

(Unit : mm)

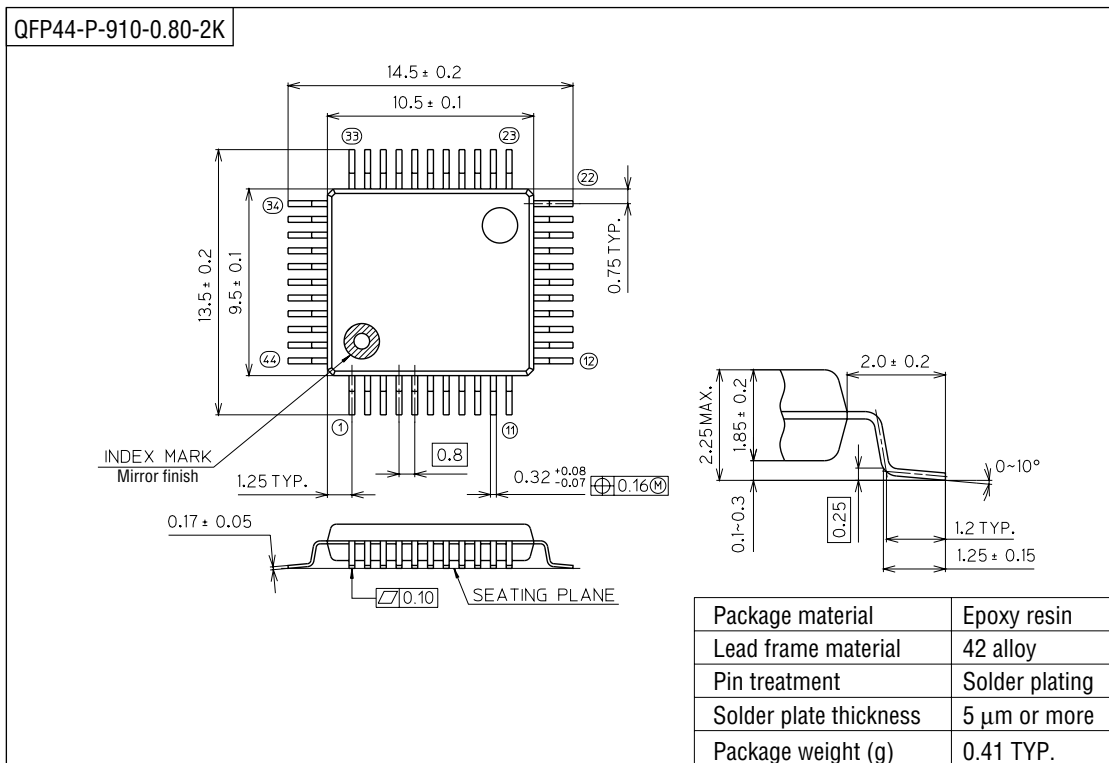

Notes for Mounting the Surface Mount Type Package

The SOP, QFP, TSOP, TQFP, LQFP, SOJ, QFJ (PLCC), SHP, and BGA are surface mount type packages, which are very susceptible to heat in reflow mounting and humidity absorbed in storage. Therefore, before you perform reflow mounting, contact responsible sales person on the product name, package name, pin number, package code and desired mounting conditions (reflow method, temperature and times).

NOTES

No copying or reproduction of this document, in part or in whole, is permitted without the consent of LAPIS Semiconductor Co., Ltd.

The content specified herein is subject to change for improvement without notice.

The content specified herein is for the purpose of introducing LAPIS Semiconductor's products (hereinafter "Products"). If you wish to use any such Product, please be sure to refer to the specifications, which can be obtained from LAPIS Semiconductor upon request.

Examples of application circuits, circuit constants and any other information contained herein illustrate the standard usage and operations of the Products. The peripheral conditions must be taken into account when designing circuits for mass production.

Great care was taken in ensuring the accuracy of the information specified in this document. However, should you incur any damage arising from any inaccuracy or misprint of such information, LAPIS Semiconductor shall bear no responsibility for such damage.

The technical information specified herein is intended only to show the typical functions of and examples of application circuits for the Products. LAPIS Semiconductor does not grant you, explicitly or implicitly, any license to use or exercise intellectual property or other rights held by LAPIS Semiconductor and other parties. LAPIS Semiconductor shall bear no responsibility whatsoever for any dispute arising from the use of such technical information.

The Products specified in this document are intended to be used with general-use electronic equipment or devices (such as audio visual equipment, office-automation equipment, communication devices, electronic appliances and amusement devices).

The Products specified in this document are not designed to be radiation tolerant.

While LAPIS Semiconductor always makes efforts to enhance the quality and reliability of its Products, a Product may fail or malfunction for a variety of reasons.

Please be sure to implement in your equipment using the Products safety measures to guard against the possibility of physical injury, fire or any other damage caused in the event of the failure of any Product, such as derating, redundancy, fire control and fail-safe designs. LAPIS Semiconductor shall bear no responsibility whatsoever for your use of any Product outside of the prescribed scope or not in accordance with the instruction manual.

The Products are not designed or manufactured to be used with any equipment, device or system which requires an extremely high level of reliability the failure or malfunction of which may result in a direct threat to human life or create a risk of human injury (such as a medical instrument, transportation equipment, aerospace machinery, nuclear-reactor controller, fuel-controller or other safety device). LAPIS Semiconductor shall bear no responsibility in any way for use of any of the Products for the above special purposes. If a Product is intended to be used for any such special purpose, please contact a ROHM sales representative before purchasing.

If you intend to export or ship overseas any Product or technology specified herein that may be controlled under the Foreign Exchange and the Foreign Trade Law, you will be required to obtain a license or permit under the Law.