ML610Q482P

8-bit Microcontroller

GENERAL DESCRIPTION

This LSI is a high-performance 8-bit CMOS microcontroller into which rich peripheral circuits, such as synchronous serial port, UART, I²C bus interface (master), buzzer driver, battery level detect circuit, and RC oscillation type A/D converter, are incorporated around 8-bit CPU nX-U8/100.

The CPU nX-U8/100 is capable of efficient instruction execution in 1-instruction 1-clock mode by 3-stage pipe line architecture parallel processing. The Flash ROM that is installed as program memory achieves low-voltage low-power consumption operation (read operation) equivalent to mask ROM and is most suitable for battery-driven applications.

The on-chip debug function that is installed enables program debugging and programming.

FEATURES

- CPU
 - 8-bit RISC CPU (CPU name: nX-U8/100)
 - Instruction system: 16-bit instructions
 - Instruction set: Transfer, arithmetic operations, comparison, logic operations, multiplication/division, bit manipulations, bit logic operations, jump, conditional jump, call return stack manipulations, arithmetic shift, and so on
 - On-Chip debug function
 - Minimum instruction execution time
 - 30.5 μ s (@32.768 kHz system clock)
 - 0.244 μ s (@4.096 MHz system clock)
- Internal memory
 - Internal 64KByte Flash ROM (32K \times 16 bits) (including unusable 1KByte TEST area)
 - Internal 4KByte Data RAM (4096 \times 8 bits)
- Interrupt controller
 - 2 non-maskable interrupt sources (Internal source: 1, External source: 1)
 - 18 maskable interrupt sources (Internal sources: 14, External sources: 4)
- Time base counter
 - Low-speed time base counter \times 1 channel
 - Frequency compensation (Compensation range: Approx. -488 ppm to $+488$ ppm. Compensation accuracy: Approx. 0.48ppm)
 - High-speed time base counter \times 1 channel
- Watchdog timer
 - Non-maskable interrupt and reset
 - Free running
 - Overflow period: 4 types selectable (125ms, 500ms, 2s, and 8s @32.768 kHz)
- Timers
 - 8 bits \times 4 channels (Timer0-3: 16-bit \times 2 configuration available by using Timer0-1 or Timer2-3)
 - Clock frequency measurement mode (in one channel of 16-bit configuration using Timer2-3)

- PWM
 - Resolution 16 bits × 1 channel
- Synchronous serial port
 - Master/slave selectable
 - LSB first/MSB first selectable
 - 8-bit length/16-bit length selectable
- UART
 - TXD/RXD × 1 channel
 - Bit length, parity/no parity, odd parity/even parity, 1 stop bit/2 stop bits
 - Positive logic/negative logic selectable
 - Built-in baud rate generator
- I²C bus interface
 - Master function only
 - Fast mode (400 kbps@4MHz), standard mode (100 kbps@1MHz, 50kbps@500kHz)
- Buzzer driver
 - 4 output modes, 8 frequencies, 16 duty levels
- RC oscillation type A/D converter
 - 24-bit counter
 - Time division × 2 channels
- Analog Comparator
 - Operating voltage: $V_{DD}=1.8V\sim 3.6V$
 - Common mode input voltage: $0.2V\sim V_{DD}-1.0V$
 - Input offset voltage: 50mV(max)
 - Interrupt allow edge selection and sampling selection
- General-purpose ports
 - Non-maskable interrupt input port × 1 channel
 - Input-only port × 6 channels (including secondary functions)
 - Output-only port × 4 channels (including secondary functions)
 - Input/output port × 22 channels (including secondary functions)
- Reset
 - Reset through the RESET_N pin
 - Power-on reset generation when powered on
 - Reset when oscillation stop of the low-speed clock is detected
 - Reset by the watchdog timer (WDT) overflow
- Power supply voltage detect function
 - Judgment voltages: One of 16 levels
 - Judgment accuracy: ±2% (Typ.)
- Clock
 - Low-speed clock: (This LSI can not guarantee the operation without low-speed clock)
Crystal oscillation (32.768 kHz/38.4KHz)
 - High-speed clock:
Built-in RC oscillation (500 kHz)
Built-in PLL oscillation (8.192 MHz ±2.5%), crystal/ceramic oscillation (4.096 MHz), external clock
 - Selection of high-speed clock mode by software:
Built-in RC oscillation, built-in PLL oscillation, crystal/ceramic oscillation, external clock

- Power management
 - HALT mode: Instruction execution by CPU is suspended (peripheral circuits are in operating states).
 - STOP mode: Stop of low-speed oscillation and high-speed oscillation (Operations of CPU and peripheral circuits are stopped.)
 - Clock gear: The frequency of high-speed system clock can be changed by software (1/1, 1/2, 1/4, or 1/8 of the oscillation clock)
 - Block Control Function: Power down (reset registers and stop clock supply) the circuits of unused peripherals.

- Shipment
 - Chip
ML610Q482P-xxxWA (Blank product: ML610Q482P-NNNWA)
 - 48-pin plastic TQFP
ML610Q482P-xxxTBZ03A (Blank product: ML610Q482P-NNNTBZ03A)
xxx: ROM code number

- Guaranteed operating range
 - Operating temperature: -40°C to $+85^{\circ}\text{C}$
 - Operating voltage: $V_{\text{DD}} = 1.1\text{V}$ to 3.6V

BLOCK DIAGRAM
ML610Q482P Block Diagram

Figure 1 show the block diagram of the ML610Q482P.
 "*" indicates the secondary function of each port.

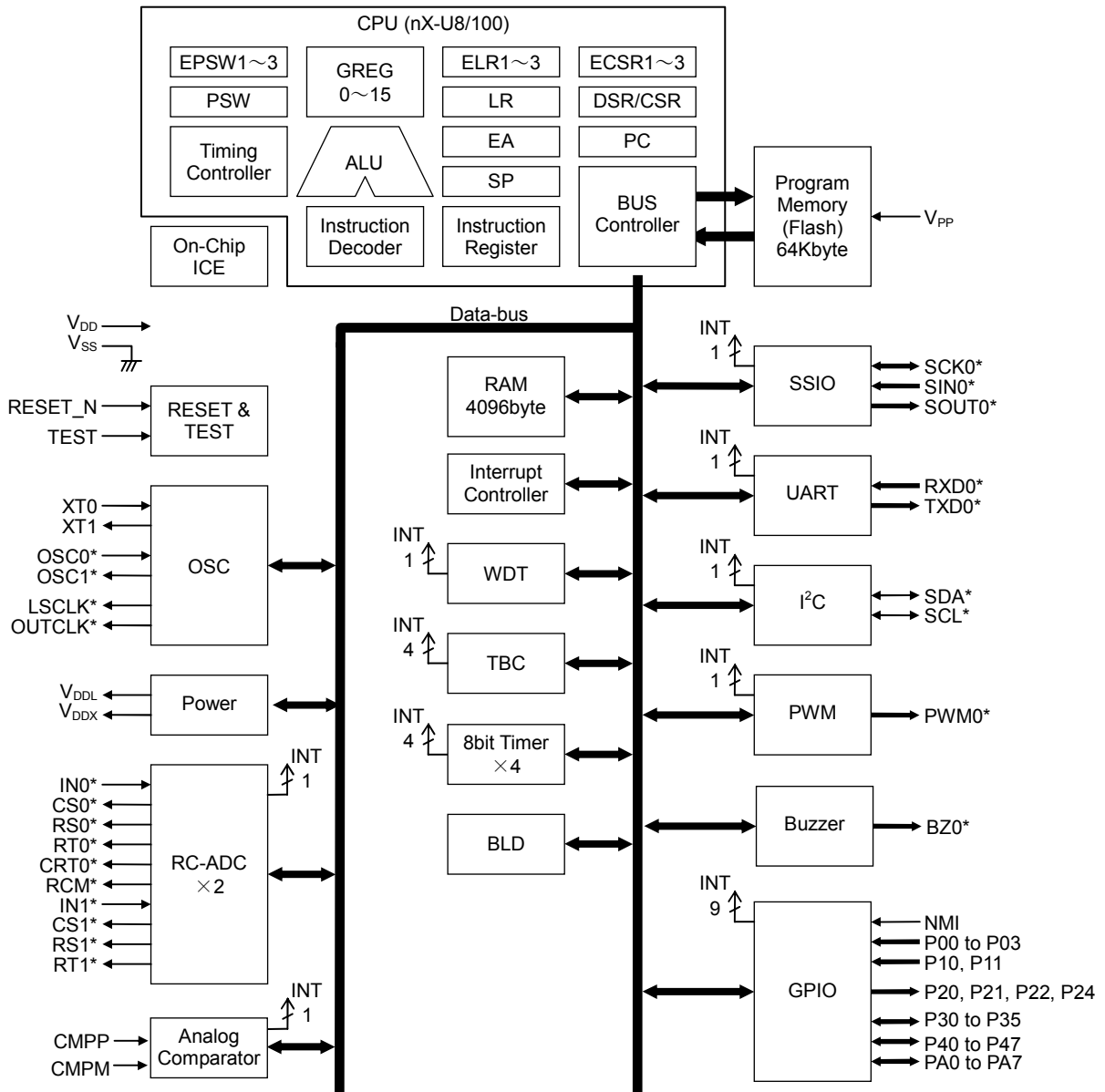
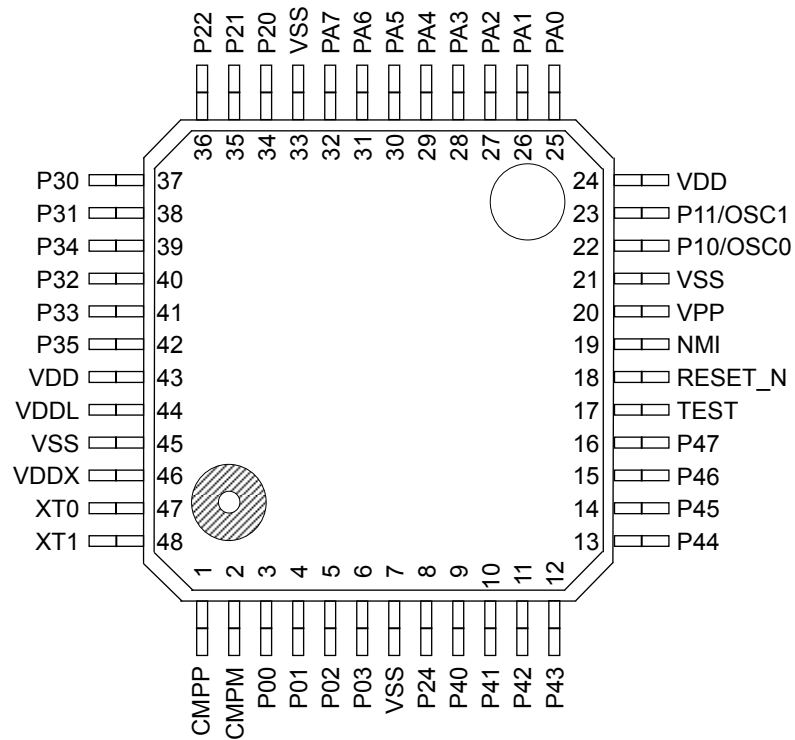

Figure 1 ML610Q482P Block Diagram

PIN CONFIGURATION

ML610Q482P TQFP48 Pin Layout



Note:
The assignment of the pads P30 to P35 are not in order.

Figure 2 ML610Q482P TQFP48 Pin Configuration

ML610Q482P Chip Pin Layout & Dimension

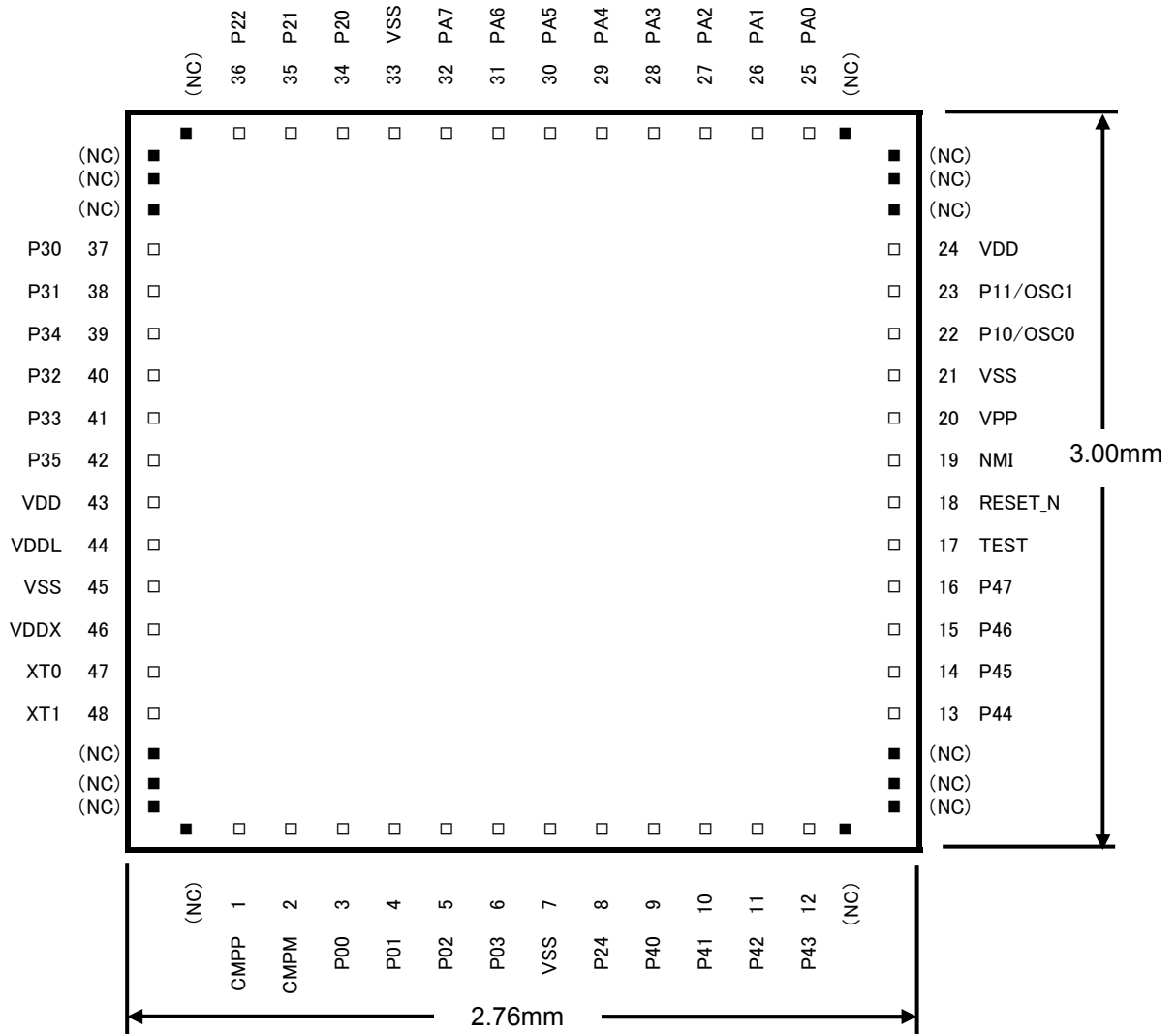

(NC): No Connection

Note:

The assignment of the pads P30 to P35 are not in order.

Chip size: 2.76 mm × 3.00 mm
 PAD count: 48 pins
 Minimum PAD pitch: 100 μm
 PAD aperture: 80 μm × 80 μm
 Chip thickness: 350 μm
 Voltage of the rear side of chip: V_{SS} level

Figure 3 ML610Q482P Chip Layout & Dimension

ML610Q482P Pad Coordinates

Table 1 ML610Q482P Pad Coordinates

				Chip Center: X=0,Y=0			
PAD No.	Pad Name	X (μm)	Y (μm)	PAD No.	Pad Name	X (μm)	Y (μm)
1	CMPP	-1036.0	-1380.0	25	PA0	1023.0	1380.0
2	CMPM	-830.0	-1380.0	26	PA1	775.0	1380.0
3	P00	-730.0	-1380.0	27	PA2	651.0	1380.0
4	P01	-482.0	-1380.0	28	PA3	403.0	1380.0
5	P02	-382.0	-1380.0	29	PA4	279.0	1380.0
6	P03	-134.0	-1380.0	30	PA5	31.0	1380.0
7	VSS	-34.0	-1380.0	31	PA6	-93.0	1380.0
8	P24	219.0	-1380.0	32	PA7	-341.0	1380.0
9	P40	327.0	-1380.0	33	VSS	-458.0	1380.0
10	P41	655.0	-1380.0	34	P20	-666.0	1380.0
11	P42	775.0	-1380.0	35	P21	-766.0	1380.0
12	P43	1023.0	-1380.0	36	P22	-1032.0	1380.0
13	P44	1260.0	-912.0	37	P30	-1260.0	922.0
14	P45	1260.0	-778.0	38	P31	-1260.0	769.0
15	P46	1260.0	-530.0	39	P34	-1260.0	521.0
16	P47	1260.0	-426.0	40	P32	-1260.0	417.0
17	TEST	1260.0	-167.0	41	P33	-1260.0	169.0
18	RESET_N	1260.0	-67.0	42	P35	-1260.0	67.0
19	NMI	1260.0	181.0	43	VDD	-1260.0	-122.0
20	VPP	1260.0	281.0	44	VDDL	-1260.0	-333.0
21	VSS	1260.0	411.0	45	VSS	-1260.0	-503.0
22	P10	1261.3	610.0	46	VDDX	-1260.0	-673.0
23	P11	1261.3	858.0	47	XT0	-1260.0	-773.0
24	VDD	1260.0	1010.0	48	XT1	-1260.0	-1021.0

PIN LIST

PAD No.	Primary function			Secondary function			Tertiary function		
	Pin name	I/O	Function	Pin name	I/O	Function	Pin name	I/O	Function
7,21,33,45	V _{SS}	—	Negative power supply pin	—	—	—	—	—	—
24,43	V _{DD}	—	Positive power supply pin	—	—	—	—	—	—
44	V _{DDL}	—	Power supply pin for internal logic (internally generated)	—	—	—	—	—	—
46	V _{DDX}	—	Power supply pin for low-speed oscillation (internally generated)	—	—	—	—	—	—
20	V _{PP}	—	Power supply pin for Flash ROM	—	—	—	—	—	—
17	TEST	I/O	Input/output pin for testing	—	—	—	—	—	—
18	RESET _N	I	Reset input pin	—	—	—	—	—	—
47	XT0	I	Low-speed clock oscillation pin	—	—	—	—	—	—
48	XT1	O	Low-speed clock oscillation pin	—	—	—	—	—	—
19	NMI	I	Non-maskable interrupt pin	—	—	—	—	—	—
3	P00/EXI0	I	Input port, External interrupt 0, Capture 0 input	—	—	—	—	—	—
4	P01/EXI1	I	Input port, External interrupt 1, Capture 1 input	—	—	—	—	—	—
5	P02/EXI2/RXD0	I	Input port, External interrupt 2, UART0 receive	—	—	—	—	—	—
6	P03/EXI3	I	Input port, External interrupt 3	—	—	—	—	—	—
1	CMPP	I	Analog comparator non-inverted input	—	—	—	—	—	—
2	CMPM	I	Analog comparator inverted input	—	—	—	—	—	—
22	P10	I	Input port	OSC0	I	High-speed oscillation	—	—	—
23	P11	I	Input port	OSC1	O	High-speed oscillation	—	—	—
34	P20/LED0	O	Output port	LSCLK	O	Low-speed clock output	—	—	—
35	P21/LED1	O	Output port	OUTCLK	O	High-speed clock output	—	—	—
36	P22/LED2	O	Output port	BZ0	O	BZ0 output	—	—	—
8	P24/LED4	O	Output port	PWM0	O	PWM0 output	—	—	—
37	P30	I/O	Input/output port	IN0	I	RC type ADC0 oscillation input pin	—	—	—
38	P31	I/O	Input/output port	CS0	O	RC type ADC0 reference capacitor connection pin	—	—	—
40	P32	I/O	Input/output port	RS0	O	RC type ADC0 reference resistor connection pin	—	—	—
41	P33	I/O	Input/output port	RT0	O	RC type ADC0 resistor sensor connection pin	—	—	—
39	P34	I/O	Input/output port	RCT0	O	RC type ADC0 resistor/capacitor sensor connection pin	PWM0	O	PWM0 output

PAD No.	Primary function			Secondary function			Tertiary function		
	Pin name	I/O	Function	Pin name	I/O	Function	Pin name	I/O	Function
42	P35	I/O	Input/output port	RCM	O	RC type ADC oscillation monitor	—	—	—
9	P40	I/O	Input/output port	SDA	I/O	I ² C data input/output	SIN0	I	SSIO data input
10	P41	I/O	Input/output port	SCL	I/O	I ² C clock input/output	SCK0	I/O	SSIO synchronous clock
11	P42	I/O	Input/output port	RXD0	I	UART data input	SOUT0	I	SSIO data output
12	P43	I/O	Input/output port	TXD0	O	UART data output	PWM0	O	PWM output
13	P44/T02 POCK	I/O	Input/output port, Timer 0/Timer 2/PWM0 external clock input	IN1	I	RC type ADC1 oscillation input pin	SIN0	I	SSIO0 data input
14	P45/T13 P1CK	I/O	Input/output port, Timer 1/Timer 3 external clock input	CS1	O	RC type ADC1 reference capacitor connection pin	SCK0	I/O	SSIO0 synchronous clock
15	P46	I/O	Input/output port	RS1	O	RC type ADC1 reference resistor connection pin	SOUT0	O	SSIO0 data output
16	P47	I/O	Input/output port	RT1	O	RC type ADC1 resistor sensor connection pin	—	—	—
25	PA0	I/O	Input/output port	—	—	—	—	—	—
26	PA1	I/O	Input/output port	—	—	—	—	—	—
27	PA2	I/O	Input/output port	—	—	—	—	—	—
28	PA3	I/O	Input/output port	—	—	—	—	—	—
29	PA4	I/O	Input/output port	—	—	—	—	—	—
30	PA5	I/O	Input/output port	—	—	—	—	—	—
31	PA6	I/O	Input/output port	—	—	—	—	—	—
32	PA7	I/O	Input/output port	—	—	—	—	—	—

PIN DESCRIPTION

Pin name	I/O	Description	Primary/ Secondary/ Tertiary	Logic
System				
RESET_N	I	Reset input pin. When this pin is set to a "L" level, system reset mode is set and the internal section is initialized. When this pin is set to a "H" level subsequently, program execution starts. A pull-up resistor is internally connected.	—	Negative
XT0	I	Crystal connection pin for low-speed clock.	—	—
XT1	O	A 32.768 kHz crystal oscillator (see measuring circuit 1) is connected to this pin. Capacitors CDL and CGL are connected across this pin and V _{SS} as required.	—	—
OSC0	I	Crystal/ceramic connection pin for high-speed clock.	Secondary	—
OSC1	O	A crystal or ceramic is connected to this pin (4.1 MHz max.). Capacitors CDH and CGH (see measuring circuit 1) are connected across this pin and V _{SS} . This pin is used as the secondary function of the P10 pin(OSC0) and P11 pin(OSC1).	Secondary	—
LSCLK	O	Low-speed clock output pin. This pin is used as the secondary function of the P20 pin.	Secondary	—
OUTCLK	O	High-speed clock output pin. This pin is used as the secondary function of the P21 pin.	Secondary	—
General-purpose input port				
P00-P03	I	General-purpose input port. Since these pins have secondary functions, the pins cannot be used as a port when the secondary functions are used.	Primary	Positive
P10,P11	I	General-purpose input port. Since these pins have secondary functions, the pins cannot be used as a port when the secondary functions are used.	Primary	Positive
General-purpose output port				
P20,P21, P22,P24	O	General-purpose output port. Since these pins have secondary functions, the pins cannot be used as a port when the secondary functions are used.	Primary	Positive
General-purpose input/output port				
P30-P35	I/O	General-purpose input/output port. Since these pins have secondary functions, the pins cannot be used as a port when the secondary functions are used.	Primary	Positive
P40-P47	I/O	General-purpose input/output port. Since these pins have secondary functions, the pins cannot be used as a port when the secondary functions are used.	Primary	Positive
PA0-PA7	I/O	General-purpose input/output port.	Primary	Positive

Pin name	I/O	Description	Primary/ Secondary/ Tertiary	Logic
UART				
TXD0	O	UART data output pin. This pin is used as the secondary function of the P43 pin.	Secondary	Positive
RXD0	I	UART data input pin. This pin is used as the secondary function of the P42 or the primary function of the P02 pin.	Primary/Secondary	Positive
I²C bus interface				
SDA	I/O	I ² C data input/output pin. This pin is used as the secondary function of the P40 pin. This pin has an NMOS open drain output. When using this pin as a function of the I ² C, externally connect a pull-up resistor.	Secondary	Positive
SCL	O	I ² C clock output pin. This pin is used as the secondary function of the P41 pin. This pin has an NMOS open drain output. When using this pin as a function of the I ² C, externally connect a pull-up resistor.	Secondary	Positive
Synchronous serial (SSIO)				
SCK0	I/O	Synchronous serial clock input/output pin. This pin is used as the tertiary function of the P41 or P45 pin.	Tertiary	—
SIN0	I	Synchronous serial data input pin. This pin is used as the tertiary function of the P40 or P44 pin.	Tertiary	Positive
SOUT0	O	Synchronous serial data output pin. This pin is used as the tertiary function of the P42 or P46 pin.	Tertiary	Positive
PWM				
PWM0	O	PWM0 output pin. This pin is used as the tertiary function of the P24 or P43 or P34 pin.	Tertiary	Positive
T02P0CK	O	PWM0 external clock input pin. This pin is used as the primary function of the P44 pin.	Primary	—
External interrupt				
NMI	I	External non-maskable interrupt input pin. An interrupt is generated on both edges.	Primary	Positive/negative
EXI0-3	I	External maskable interrupt input pins. Interrupt enable and edge selection can be performed for each bit by software. These pins are used as the primary functions of the P00-P03 pins.	Primary	Positive/negative
Timer				
T02P0CK	I	External clock input pin used for both Timer 0 and Timer 2. The clocks for these timers are selected by software. This pin is used as the primary function of the P44 pin.	Primary	—
T13P1CK	I	External clock input pin used for both Timer 1 and Timer 3. The clocks for these timers are selected by software. This pin is used as the primary function of the P45 pin.	Primary	—
Buzzer				
BZ0	O	Buzzer signal output pin. This pin is used as the secondary function of the P22 pin.	Secondary	Positive/negative
LED drive				
LED0,1,2,4	O	NMOS open drain output pins to drive LED. These pins are used as the primary function of the P20,P21,P22,P24 pins.	Primary	Positive/negative

Pin name	I/O	Description	Primary/ Secondary/ Tertiary	Logic
RC oscillation type A/D converter				
IN0	I	Channel 0 oscillation input pin. This pin is used as the secondary function of the P30 pin.	Secondary	—
CS0	O	Channel 0 reference capacitor connection pin. This pin is used as the secondary function of the P31 pin.	Secondary	—
RS0	O	This pin is used as the secondary function of the P32 pin which is the reference resistor connection pin of Channel 0.	Secondary	—
RT0	O	Resistor sensor connection pin of Channel 0 for measurement. This pin is used as the secondary function of the P34 pin.	Secondary	—
CRT0	O	Resistor/capacitor sensor connection pin of Channel 0 for measurement. This pin is used as the secondary function of the P33 pin.	Secondary	—
RCM	O	RC oscillation monitor pin. This pin is used as the secondary function of the P35 pin.	Secondary	—
IN1	I	Oscillation input pin of Channel 1. This pin is used as the secondary function of the P44 pin.	Secondary	—
CS1	O	Reference capacitor connection pin of Channel 1. This pin is used as the secondary function of the P45 pin.	Secondary	—
RS1	O	Reference resistor connection pin of Channel 1. This pin is used as the secondary function of the P46 pin.	Secondary	—
RT1	O	Resistor sensor connection pin for measurement of Channel 1. This pin is used as the secondary function of the P47 pin.	Secondary	—
Analog comparator				
CMPP	I	Non-inverted input pin.	—	—
CMPM	I	Inverted input pin.	—	—
For testing				
TEST	I/O	Input/output pin for testing. A pull-down resistor is internally connected.	—	—
Power supply				
V _{SS}	—	Negative power supply pin.	—	—
V _{DD}	—	Positive power supply pin.	—	—
V _{DDL}	—	Positive power supply pin (internally generated) for internal logic. Capacitors CL0 and CL1 (see measuring circuit 1) are connected between this pin and V _{SS} .	—	—
V _{DDX}	—	Plus-side power supply pin (internally generated) for low-speed oscillation. Capacitor Cx (see measuring circuit 1) is connected between this pin and V _{SS} .	—	—
V _{PP}	—	Power supply pin for programming Flash ROM. A pull-up resistor is internally connected.	—	—

TERMINATION OF UNUSED PINS

Table 2 shows methods of terminating the unused pins.

Table 2 Termination of Unused Pins

Pin	Recommended pin termination
V _{PP}	Open
RESET_N	Open
TEST	Open
NMI	Open
P00 to P03	V _{DD} or V _{SS}
P10, P11	V _{DD}
P20, P21, P22, P24	Open
P30 to P35	Open
P40 to P47	Open
PA0 to PA7	Open
CMPP, CPM	V _{DD}

Note:

It is recommended to set the unused input ports and input/output ports to the inputs with pull-down resistors/pull-up resistors or the output mode since the supply current may become excessively large if the pins are left open in the high impedance input setting.

ELECTRICAL CHARACTERISTICS

ABSOLUTE MAXIMUM RATINGS

(V_{SS} = 0V)

Parameter	Symbol	Condition	Rating	Unit
Power supply voltage 1	V _{DD}	Ta = 25°C	-0.3 to +4.6	V
Power supply voltage 2	V _{PP}	Ta = 25°C	-0.3 to +9.5	V
Power supply voltage 3	V _{DDL}	Ta = 25°C	-0.3 to +3.6	V
Power supply voltage 4	V _{DDX}	Ta = 25°C	-0.3 to +3.6	V
Input voltage	V _{IN}	Ta = 25°C	-0.3 to V _{DD} +0.3	V
Output voltage	V _{OUT}	Ta = 25°C	-0.3 to V _{DD} +0.3	V
Output current 1	I _{OUT1}	Port3-A, Ta = 25°C	-12 to +11	mA
Output current 2	I _{OUT2}	Port2, Ta = 25°C	-12 to +20	mA
Power dissipation	PD	Ta = 25°C	1.16	W
Storage temperature	T _{STG}	—	-55 to +150	°C

RECOMMENDED OPERATING CONDITIONS

(V_{SS} = 0V)

Parameter	Symbol	Condition	Range	Unit
Operating temperature	T _{OP}	—	-40 to +85	°C
Operating voltage	V _{DD}	—	1.1 to 3.6	V
Operating frequency (CPU)	f _{OP}	V _{DD} = 1.1 to 3.6V	30k to 36k	Hz
		V _{DD} = 1.3 to 3.6V	30k to 650k	
		V _{DD} = 1.8 to 3.6V	30k to 4.2M	
Low-speed crystal oscillation frequency	f _{XTL}	—	32.768k/38.4k	Hz
Low-speed crystal oscillation external capacitor	C _{DL}	—	0 to 12	pF
	C _{GL}	—	0 to 12	
High-speed crystal/ceramic oscillation frequency	f _{XTH}	—	4.0M / 4.096M	Hz
High-speed crystal oscillation external capacitor	C _{DH}	—	24	pF
	C _{GH}	—	24	
Capacitor externally connected to V _{DDL} pin	C _{L0}	—	1.0±30%	μF
	C _{L1}	—	0.1±30%	
Capacitor externally connected to V _{DDX} pin	C _X	—	0.1±30%	μF

OPERATING CONDITIONS OF FLASH ROM

(V_{SS} = 0V)

Parameter	Symbol	Condition	Range	Unit
Operating temperature	T _{OP}	At write/erase	0 to +40	°C
Operating voltage	V _{DD}	At write/erase ^{*1}	2.75 to 3.6	V
	V _{DDL}	At write/erase ^{*1}	2.5 to 2.75	
	V _{PP}	At write/erase ^{*1}	7.7 to 8.3	
Write cycles	C _{EP}	—	10	cycles
Data retention	Y _{DR}	—	10	years

*1: Those voltages must be supplied to V_{DDL} pin and V_{PP} pin when programming and erasing Flash ROM. V_{PP} pin has an internal pulldown resistor.

CONDITIONS OF ANALOG COMPARATOR

($V_{DD} = 1.1$ to $3.6V$, $V_{SS} = 0V$, $T_a = -40$ to $+85^{\circ}C$, unless otherwise specified) (2/4)

Parameter	Symbol	Condition	Rating			Unit	Measuring circuit
			Min.	Typ.	Max.		
Common mode Input voltage	CMV_{IN}	$V_{DD} = 1.8$ to $3.6V$	0.2	—	$V_{DD} - 1$	V	1
Input offset voltage	V_{CMPOF}	$V_{DD} = 1.8$ to $3.6V$, $T_a = 25^{\circ}C$	—	—	50	mV	
Response time	T_{CMP}	$V_{DD} = 1.8$ to $3.6V$, $T_a = 25^{\circ}C$ Over drive = $100mV$	—	—	100	μs	
Wake-up time	T_{CMPW}		—	—	3	ms	
Circuit current (during operation)	I_{CMP}	$V_{DD} = 1.8$ to $3.6V$, $T_a = 25^{\circ}C$	—	2	4	μA	

DC CHARACTERISTICS (1/4)

($V_{DD} = 1.1$ to $3.6V$, $V_{SS} = 0V$, $T_a = -40$ to $+85^{\circ}C$, unless otherwise specified) (1/4)

Parameter	Symbol	Condition	Rating			Unit	Measuring circuit	
			Min.	Typ.	Max.			
500kHz RC oscillation frequency	f_{RC}	$V_{DD} = 1.3$ to $3.6V$	$T_a = 25^{\circ}C$	Typ. -10%	500	Typ. +10%	kHz	1
			$T_a = -40$ to $+85^{\circ}C$	Typ. -35%	500	Typ. +35%	kHz	
PLL oscillation frequency*4	f_{PLL}	LSCLK = $32.768kHz$ $V_{DD} = 1.8$ to $3.6V$	-2.5%	8.192	+2.5%	MHz		
Low-speed crystal oscillation start time*2	T_{XTL}	—	—	0.3	2	s		
500kHz RC oscillation start time	T_{RC}	—	—	50	500	μs		
High-speed crystal oscillation start time*3	T_{XTH}	$V_{DD} = 1.8$ to $3.6V$	—	2	20	ms		
PLL oscillation start time	T_{PLL}	$V_{DD} = 1.8$ to $3.6V$	—	1	10			
Low-speed oscillation stop detect time*1	T_{STOP}	—	0.2	3	20	μs		
Reset pulse width	P_{RST}	—	200	—	—			
Reset noise elimination pulse width	P_{NRST}	—	—	—	0.3	μs		
Power-on reset activation power rise time	T_{POR}	—	—	—	10	ms		

*1: When low-speed crystal oscillation stops for a duration more than the low-speed oscillation stop detect time, the system is reset to shift to system reset mode.

*2: Use 32.768KHz Crystal Oscillator C-001R (Epson Toyocom) with capacitance $C_{GL}/C_{DL} = 0pF$.

*3: Use 4.096MHz Crystal Oscillator CHC49SFWB (Kyocera).

*4: 1024 clock average.

RESET

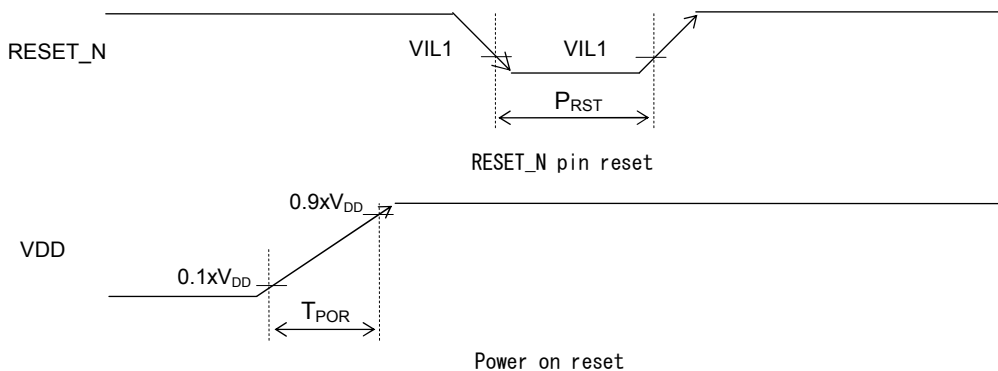

DC CHARACTERISTICS (2/4)

(V_{DD} = 1.1 to 3.6V, V_{SS} = 0V, Ta = -40 to +85°C, unless otherwise specified) (2/4)

Parameter	Symbol	Condition		Rating			Unit	Measuring circuit		
				Min.	Typ.	Max.				
BLD threshold voltage	V _{BLD}	V _{DD} = 1.35 to 3.6V		Typ. -2%		Typ. +2%	V	1		
									LD2-0 = 0H	1.35
									LD2-0 = 1H	1.4
									LD2-0 = 2H	1.45
									LD2-0 = 3H	1.5
									LD2-0 = 4H	1.6
									LD2-0 = 5H	1.7
									LD2-0 = 6H	1.8
									LD2-0 = 7H	1.9
									LD2-0 = 8H	2.0
									LD2-0 = 9H	2.1
									LD2-0 = 0AH	2.2
									LD2-0 = 0BH	2.3
									LD2-0 = 0CH	2.4
LD2-0 = 0DH	2.5									
LD2-0 = 0EH	2.7									
LD2-0 = 0FH	2.9									
BLD threshold voltage temperature deviation	ΔV _{BLD}	V _{DD} = 1.35 to 3.6V		—	0	—	%/°C			
Supply current 1	IDD1	CPU: In STOP state. Low-speed/high-speed oscillation: stopped.		Ta=25°C	—	0.2	0.5	μA		
				Ta=-40 to +85°C	—	—	5			
Supply current 2	IDD2	CPU: In HALT state (LTBC,WDT:Operating* ³). High-speed oscillation: Stopped.		Ta=25°C	—	0.5	1.3	μA		
				Ta=-40 to +85°C	—	—	6			
Supply current 3	IDD3	CPU: In 32.768kHz operating state.* ¹ High-speed oscillation: Stopped.		Ta=25°C	—	5	7	μA		
				Ta=-40 to +85°C	—	—	12			
Supply current 4	IDD4	CPU: In 500kHz CR operating state.		Ta=25°C	—	70	85	μA		
				Ta=-40 to +85°C	—	—	100			
Supply current 5	IDD5	CPU: In 4.096MHz operating state.PLL: In oscillating state.V _{DD} = 1.8 to 3.6V		Ta=25°C	—	0.83	1	mA		
				Ta=-40 to +85°C	—	—	1.2			
Supply current 6	IDD6	CPU: In 4.096MHz operating state.Crystal/ceramic: In oscillating state.* ^{1*2} V _{DD} = 3.0V		Ta=25°C	—	1.3	1.4	mA		
				Ta=-40 to +85°C	—	—	2.0			

*¹ : Use 32.768KHz Crystal Oscillator C-001R (Epson Toyocom) with capacitance C_{GL}/C_{DL}=0pF.*² : Use 4.096MHz Crystal Oscillator CHC49SFWB (Kyocera).*³ : Significant bits of BLKCON0~BLKCON4 registers are all "1".

DC CHARACTERISTICS (3/4)

(V_{DD} = 1.1 to 3.6V, V_{SS} = 0V, Ta = -40 to +85°C, unless otherwise specified) (3/4)

Parameter	Symbol	Condition	Rating			Unit	Measuring circuit	
			Min.	Typ.	Max.			
Output voltage 1 (P20, P21, P22, P24/2 nd function is selected) (P30–P35) (P40–P47) (PA0–PA7)	VOH1	IOH1 = -0.5mA, V _{DD} = 1.8 to 3.6V	V _{DD} -0.5	—	—	V	2	
		IOH1 = -0.1mA, V _{DD} = 1.3 to 3.6V	V _{DD} -0.3	—	—			
		IOH1 = -0.03mA, V _{DD} = 1.1 to 3.6V	V _{DD} -0.3					
	VOL1	IOL1 = +0.5mA, V _{DD} = 1.8 to 3.6V	—	—	0.5			
		IOL1 = +0.1mA, V _{DD} = 1.3 to 3.6V	—	—	0.5			
		IOL1 = +0.03mA, V _{DD} = 1.1 to 3.6V	—	—	0.3			
Output voltage 2 (P20, P21, P22, P24/2 nd function is Not selected)	VOL2	IOL2 = +5mA, V _{DD} = 1.8 to 3.6V	—	—	0.5			
Output voltage 3 (P40, P41)	VOL3	IOL3 = +3mA, V _{DD} = 2.0 to 3.6V (when I ² C mode is selected)	—	—	0.4			
Output leakage (P20, P21, P22, P24) (P30–P35) (P40–P47) (PA0–PA7) ^{*1}	IOOH	VOH = V _{DD} (in high-impedance state)	—	—	1	μA	3	
	IOOL	VOL = V _{SS} (in high-impedance state)	-1	—	—			
Input current 1 (RESET_N)	IIH1	VIH1 = V _{DD}		0	—	1	μA	4
	IIL1	VIL1 = V _{SS}	V _{DD} = 1.8 to 3.6V	-600	-300	-20		
			V _{DD} = 1.3 to 3.6V	-600	-300	-10		
V _{DD} = 1.1 to 3.6V			-600	-300	-2			
Input current 1 (TEST)	IIH1	VIH1 = V _{DD}	V _{DD} = 1.8 to 3.6V	20	300	600		
			V _{DD} = 1.3 to 3.6V	10	300	600		
			V _{DD} = 1.1 to 3.6V	2	300	600		
	IIL1	VIL1 = V _{SS}		-1	—	—		
	Input current 2 (NMI) (P00–P03) (P10, P11) (P30–P35) (P40–P47) (PA0–PA7)	IIH2	VIH2 = V _{DD} (when pulled-down)	V _{DD} = 1.8 to 3.6V	2	30		
V _{DD} = 1.3 to 3.6V				0.2	30	200		
V _{DD} = 1.1 to 3.6V				0.01	30	200		
IIL2		VIL2 = V _{SS} (when pulled-up)	V _{DD} = 1.8 to 3.6V	-200	-30	-2		
			V _{DD} = 1.3 to 3.6V	-200	-30	-0.2		
			V _{DD} = 1.1 to 3.6V	-200	-30	-0.01		
IIH2Z		VIH2 = V _{DD} (in high-impedance state)		—	—	1		
IIL2Z	VIL2 = V _{SS} (in high-impedance state)		-1	—	—			

DC CHARACTERISTICS (4/4) $(V_{DD} = 1.1 \text{ to } 3.6\text{V}, V_{SS} = 0\text{V}, T_a = -40 \text{ to } +85^\circ\text{C}, \text{ unless otherwise specified}) (4/4)$

Parameter	Symbol	Condition	Rating			Unit	Measuring circuit
			Min.	Typ.	Max.		
Input voltage 1 (RESET_N) (TEST) (NMI) (P00–P03) (P10, P11) (P31–P35) (P40–P43) (P45–P47) (PA0–PA7) ^{*1}	VIH1	$V_{DD} = 1.3 \text{ to } 3.6\text{V}$	0.7 $\times V_{DD}$	—	V_{DD}	V	5
		$V_{DD} = 1.1 \text{ to } 3.6\text{V}$	0.7 $\times V_{DD}$	—	V_{DD}		
	VIL1	$V_{DD} = 1.3 \text{ to } 3.6\text{V}$	0	—	0.3 $\times V_{DD}$		
		$V_{DD} = 1.1 \text{ to } 3.6\text{V}$	0	—	0.2 $\times V_{DD}$		
Input voltage 2 (P30, P44)	VIH2	—	0.7 $\times V_{DD}$	—	V_{DD}	pF	—
	VIL2	—	0	—	0.3 $\times V_{DD}$		
Input pin capacitance (NMI) (P00–P03) (P10, P11) (P30–P35) (P40–P47) (PA0–PA7)	CIN	f = 10kHz $V_{rms} = 50\text{mV}$ $T_a = 25^\circ\text{C}$	—	—	5		

MEASURING CIRCUITS

MEASURING CIRCUIT 1

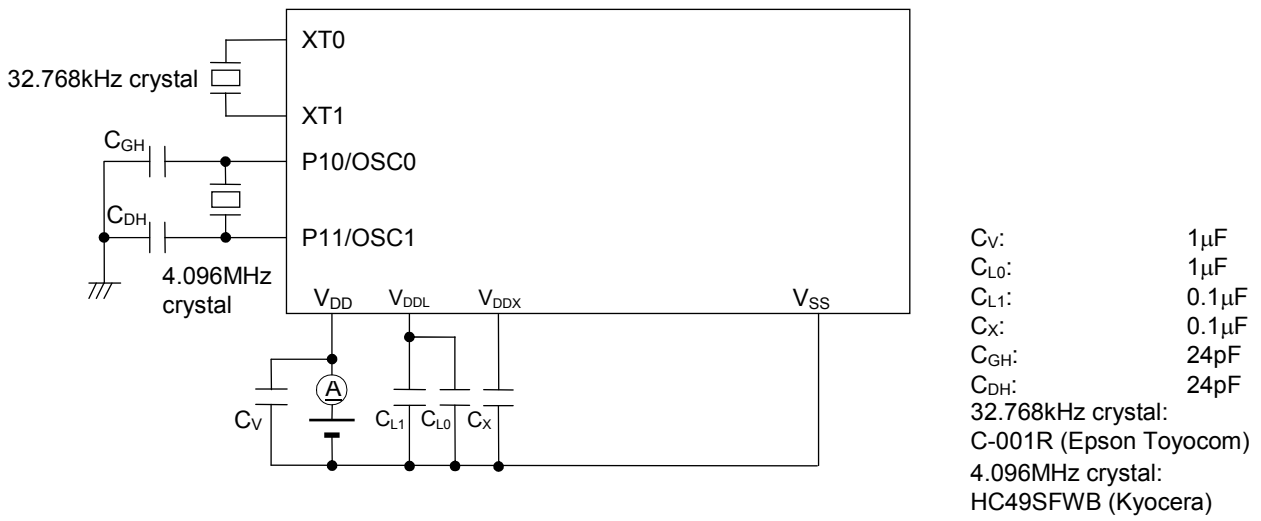

MEASURING CIRCUIT 2

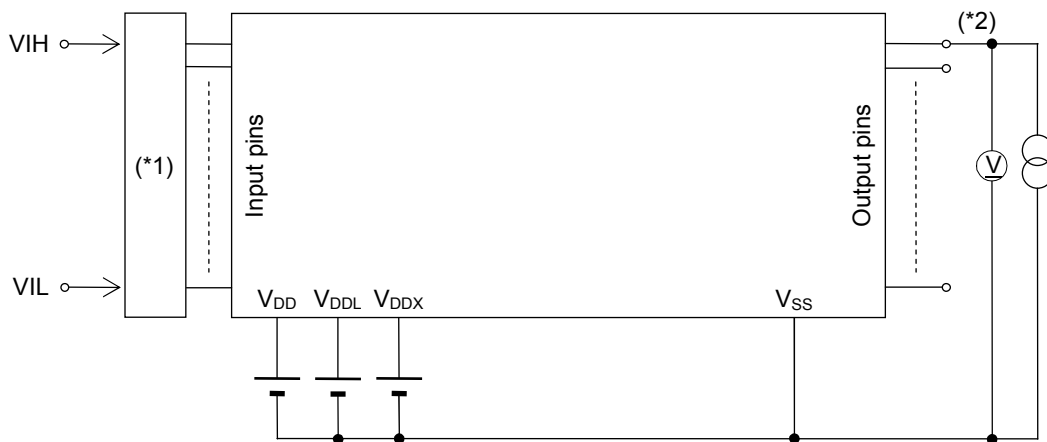

(*1) Input logic circuit to determine the specified measuring conditions.
 (*2) Measured at the specified output pins.

MEASURING CIRCUIT 3

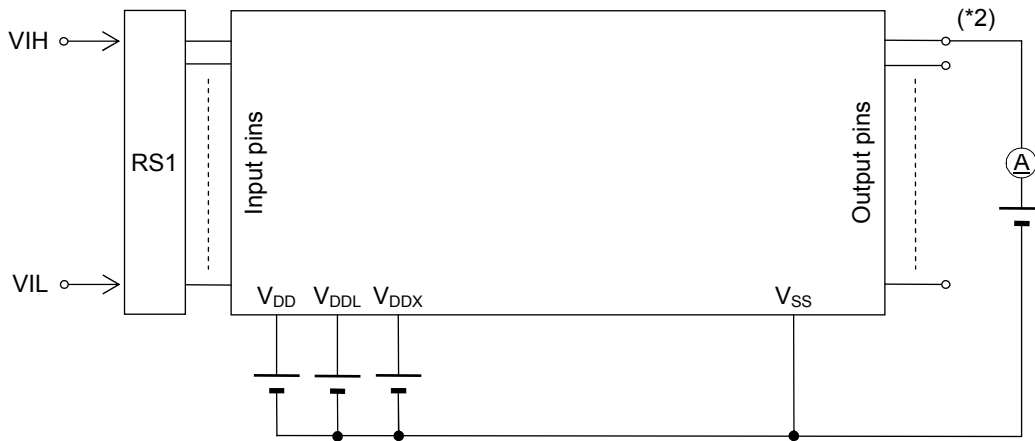

*1: Input logic circuit to determine the specified measuring conditions.
 *2: Measured at the specified output pins.

MEASURING CIRCUIT 4

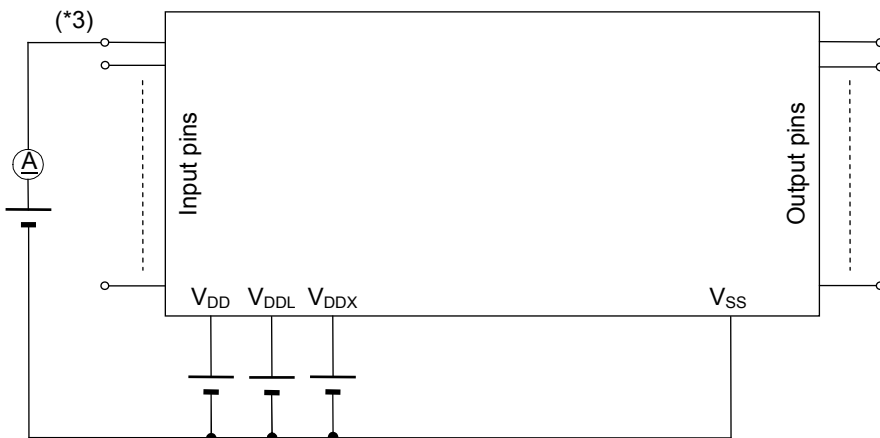

*3: Measured at the specified output pins.

MEASURING CIRCUIT 5

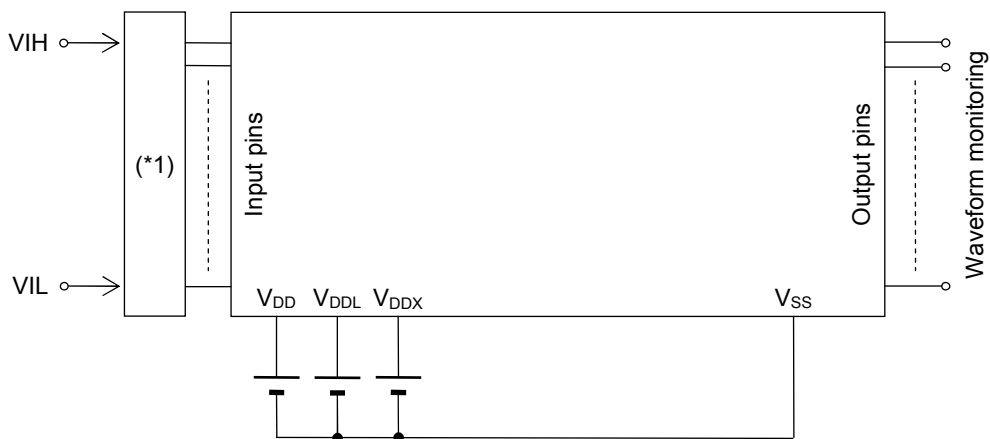

*1: Input logic circuit to determine the specified measuring conditions.

AC CHARACTERISTICS (External Interrupt)

($V_{DD} = 1.1$ to $3.6V$, $V_{SS} = 0V$, $T_a = -40$ to $+85^{\circ}C$, unless otherwise specified)

Parameter	Symbol	Condition	Rating			Unit
			Min.	Typ.	Max.	
External interrupt disable period	T_{NUL}	Interrupt: Enabled (MIE = 1), CPU: NOP operation System clock: 32.768kHz	76.8	—	106.8	μs

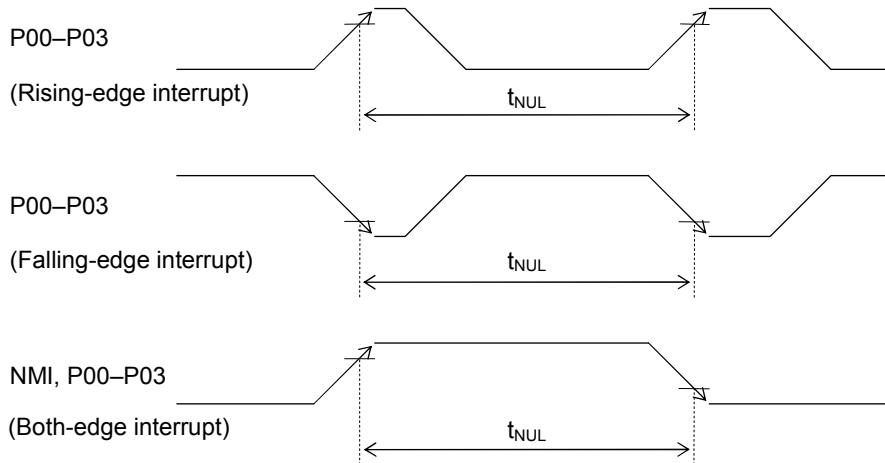

AC CHARACTERISTICS (UART)

($V_{DD} = 1.3$ to $3.6V$, $V_{SS} = 0V$, $T_a = -40$ to $+85^{\circ}C$, unless otherwise specified)

Parameter	Symbol	Condition	Rating			Unit
			Min.	Typ.	Max.	
Transmit baud rate	t_{TBRT}	—	—	BRT^{*1}	—	s
Receive baud rate	t_{RBRT}	—	BRT^{*1} -3%	BRT^{*1}	BRT^{*1} +3%	s

*1: Baud rate period (including the error of the clock frequency selected) set with the UART0 baud rate register (UA0BRTL,H) and the UART0 mode register 0 (UA0MOD0).

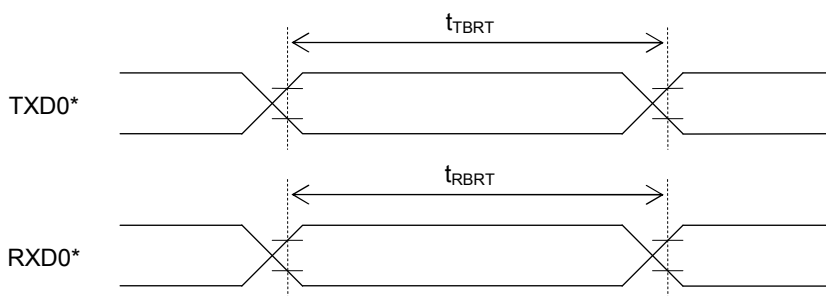

*: Indicates the secondary function of the port.

AC CHARACTERISTICS (Synchronous Serial Port) $(V_{DD} = 1.3 \text{ to } 3.6\text{V}, V_{SS} = 0\text{V}, T_a = -40 \text{ to } +85^\circ\text{C}, \text{ unless otherwise specified})$

Parameter	Symbol	Condition	Rating			Unit
			Min.	Typ.	Max.	
SCLK input cycle (slave mode)	t_{SCYC}	When RC oscillation is active ^{*2} ($V_{DD} = 1.3 \text{ to } 3.6\text{V}$)	10	—	—	μs
		When high-speed oscillation is active ^{*3} ($V_{DD} = 1.8 \text{ to } 3.6\text{V}$)	1	—	—	μs
SCLK output cycle (master mode)	t_{SCYC}	—	—	SCLK ^{*1}	—	s
SCLK input pulse width (slave mode)	t_{SW}	When RC oscillation is active ^{*2} ($V_{DD} = 1.3 \text{ to } 3.6\text{V}$)	4	—	—	μs
		When high-speed oscillation is active ^{*3} ($V_{DD} = 1.8 \text{ to } 3.6\text{V}$)	0.4	—	—	μs
SCLK output pulse width (master mode)	t_{SW}	—	SCLK ^{*1} $\times 0.4$	SCLK ^{*1} $\times 0.5$	SCLK ^{*1} $\times 0.6$	s
SOUT output delay time (slave mode)	t_{SD}	When RC oscillation is active ^{*2} ($V_{DD} = 1.3 \text{ to } 3.6\text{V}$)	—	—	500	ns
		When high-speed oscillation is active ^{*3} ($V_{DD} = 1.8 \text{ to } 3.6\text{V}$)	—	—	240	
SOUT output delay time (master mode)	t_{SD}	When RC oscillation is active ^{*2} ($V_{DD} = 1.3 \text{ to } 3.6\text{V}$)	—	—	500	ns
		When high-speed oscillation is active ^{*3} ($V_{DD} = 1.8 \text{ to } 3.6\text{V}$)	—	—	240	
SIN input setup time (slave mode)	t_{SS}	—	80	—	—	ns
SIN input setup time (master mode)	t_{SS}	When RC oscillation is active ^{*2} ($V_{DD} = 1.3 \text{ to } 3.6\text{V}$)	500	—	—	ns
		When high-speed oscillation is active ^{*3} ($V_{DD} = 1.8 \text{ to } 3.6\text{V}$)	240	—	—	
SIN input hold time	t_{SH}	When RC oscillation is active ^{*2} ($V_{DD} = 1.3 \text{ to } 3.6\text{V}$)	300	—	—	ns
		When high-speed oscillation is active ^{*3} ($V_{DD} = 1.8 \text{ to } 3.6\text{V}$)	80	—	—	

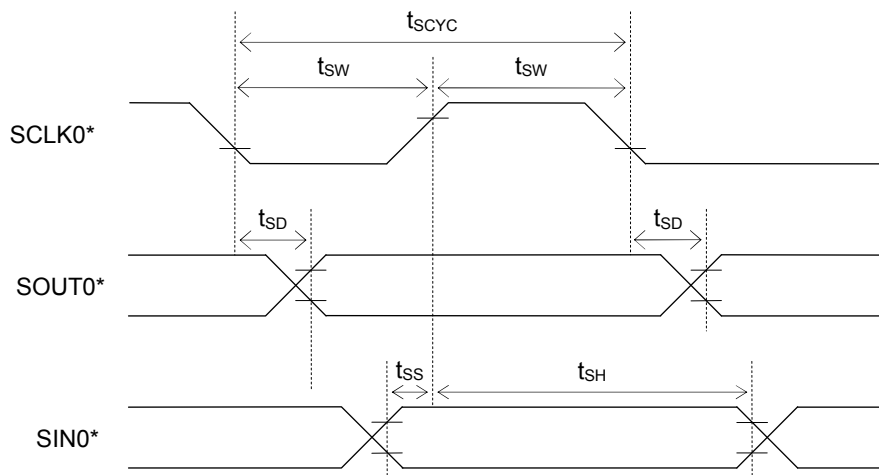
*¹: Clock period selected with S0CK3–0 of the serial port 0 mode register (SIO0MOD1)*²: When RC oscillation is selected with OSCM1–0 of the frequency control register (FCON0)*³: When Crystal/ceramic oscillation, built-in PLL oscillation, or external clock input is selected with OSCM1–0 of the frequency control register (FCON0)

*: Indicates the secondary function of the port.

AC CHARACTERISTICS (I²C Bus Interface: Standard Mode 100kbit/s)(V_{DD} = 1.8 to 3.6V, V_{SS} = 0V, Ta = -40 to +85°C, unless otherwise specified)

Parameter	Symbol	Condition	Rating			Unit
			Min.	Typ.	Max.	
SCL clock frequency	f _{SCL}	—	0	—	100	kHz
SCL hold time (start/restart condition)	t _{HD:STA}	—	4.0	—	—	μs
SCL "L" level time	t _{LOW}	—	4.7	—	—	μs
SCL "H" level time	t _{HIGH}	—	4.0	—	—	μs
SCL setup time (restart condition)	t _{SU:STA}	—	4.7	—	—	μs
SDA hold time	t _{HD:DAT}	—	0	—	—	μs
SDA setup time	t _{SU:DAT}	—	0.25	—	—	μs
SDA setup time (stop condition)	t _{SU:STO}	—	4.0	—	—	μs
Bus-free time	t _{BUF}	—	4.7	—	—	μs

AC CHARACTERISTICS (I²C Bus Interface: Fast Mode 400kbit/s)(V_{DD} = 1.8 to 3.6V, V_{SS} = 0V, Ta = -40 to +85°C, unless otherwise specified)

Parameter	Symbol	Condition	Rating			Unit
			Min.	Typ.	Max.	
SCL clock frequency	f _{SCL}	—	0	—	400	kHz
SCL hold time (start/restart condition)	t _{HD:STA}	—	0.6	—	—	μs
SCL "L" level time	t _{LOW}	—	1.3	—	—	μs
SCL "H" level time	t _{HIGH}	—	0.6	—	—	μs
SCL setup time (restart condition)	t _{SU:STA}	—	0.6	—	—	μs
SDA hold time	t _{HD:DAT}	—	0	—	—	μs
SDA setup time	t _{SU:DAT}	—	0.1	—	—	μs
SDA setup time (stop condition)	t _{SU:STO}	—	0.6	—	—	μs
Bus-free time	t _{BUF}	—	1.3	—	—	μs

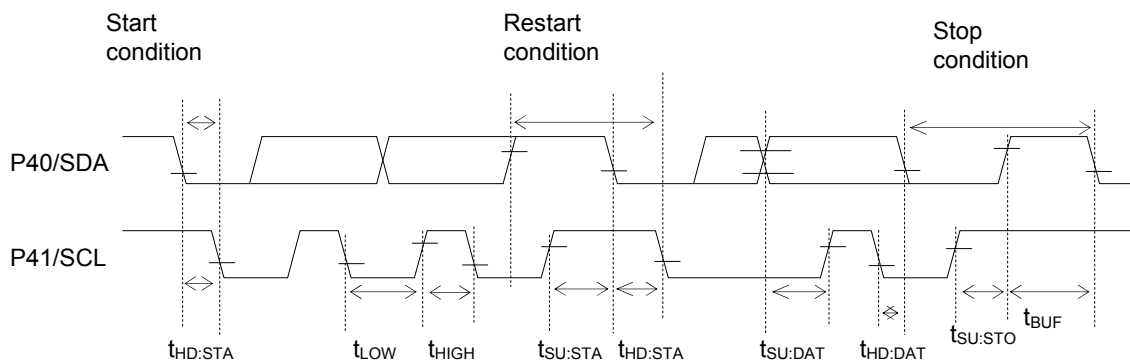

AC CHARACTERISTICS (RC Oscillation A/D Converter)

(V_{DD} = 1.3 to 3.6V, V_{SS} = 0V, Ta = -20 to +70°C, unless otherwise specified)

Parameter	Symbol	Condition	Rating			Unit
			Min.	Typ.	Max.	
Resistors for oscillation	RS0, RS1, RT0, RT0-1, RT1	CS0, CT0, CS1 ≥ 740pF	1	—	—	kΩ
Oscillation frequency VDD = 1.5V	f _{OSC1}	Resistor for oscillation = 1kΩ	209.4	330.6	435.1	kHz
	f _{OSC2}	Resistor for oscillation = 10kΩ	41.29	55.27	64.16	kHz
	f _{OSC3}	Resistor for oscillation = 100kΩ	4.71	5.97	7.06	kHz
RS to RT oscillation frequency ratio ^{*1} VDD = 1.5V	Kf1	RT0, RT0-1, RT1 = 1kHz	5.567	5.982	6.225	—
	Kf2	RT0, RT0-1, RT1 = 10kHz	0.99	1	1.01	—
	Kf3	RT0, RT0-1, RT1 = 100kHz	0.104	0.108	0.118	—
Oscillation frequency VDD = 3.0V	f _{OSC1}	Resistor for oscillation = 1kΩ	407.3	486.7	594.6	kHz
	f _{OSC2}	Resistor for oscillation = 10kΩ	49.76	59.28	72.76	kHz
	f _{OSC3}	Resistor for oscillation = 100kΩ	5.04	5.993	7.04	kHz
RS to RT oscillation frequency ratio ^{*1} VDD = 3.0V	Kf1	RT0, RT0-1, RT1 = 1kHz	8.006	8.210	8.416	—
	Kf2	RT0, RT0-1, RT1 = 10kHz	0.99	1	1.01	—
	Kf3	RT0, RT0-1, RT1 = 100kHz	0.100	0.108	0.115	—

*1: Kfx is the ratio of the oscillation frequency by the sensor resistor to the oscillation frequency by the reference resistor on the same conditions.

$$Kfx = \frac{f_{oscx}(RT0-CS0 \text{ oscillation})}{f_{oscx}(RS0-CS0 \text{ oscillation})}, \quad \frac{f_{oscx}(RT0-1-CS0 \text{ oscillation})}{f_{oscx}(RS0-CS0 \text{ oscillation})}, \quad \frac{f_{oscx}(RT1-CS1 \text{ oscillation})}{f_{oscx}(RS1-CS1 \text{ oscillation})}$$

(x = 1, 2, 3)

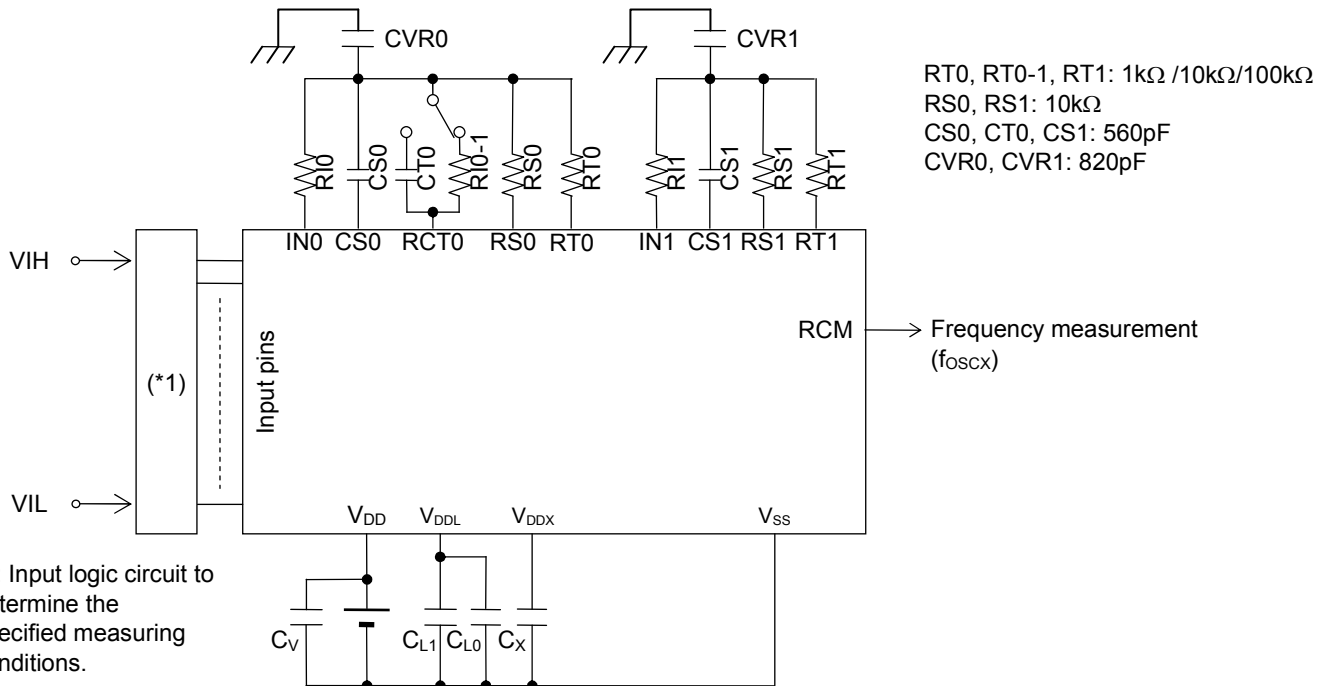

Note:

- Please have the shortest layout for the common node (wiring patterns which are connected to the external capacitors, resistors and IN0/IN1 pin), including CVR0/CVR1. Especially, do not have long wire between IN0/IN1 and RS0/RS1. The coupling capacitance on the wires may occur incorrect A/D conversion. Also, please do not have signals which may be a source of noise around the node.
- When RT0/RT1 (Thermistor and etc.) requires long wiring due to the restricted placement, please have VSS(GND) trace next to the signal.
- Please make wiring to components (capacitor, resistor and etc.) necessary for objective measurement. Wiring to reserved components may affect to the A/D conversion operation by noise the components itself may have.

Package Dimensions

(Unit: mm)

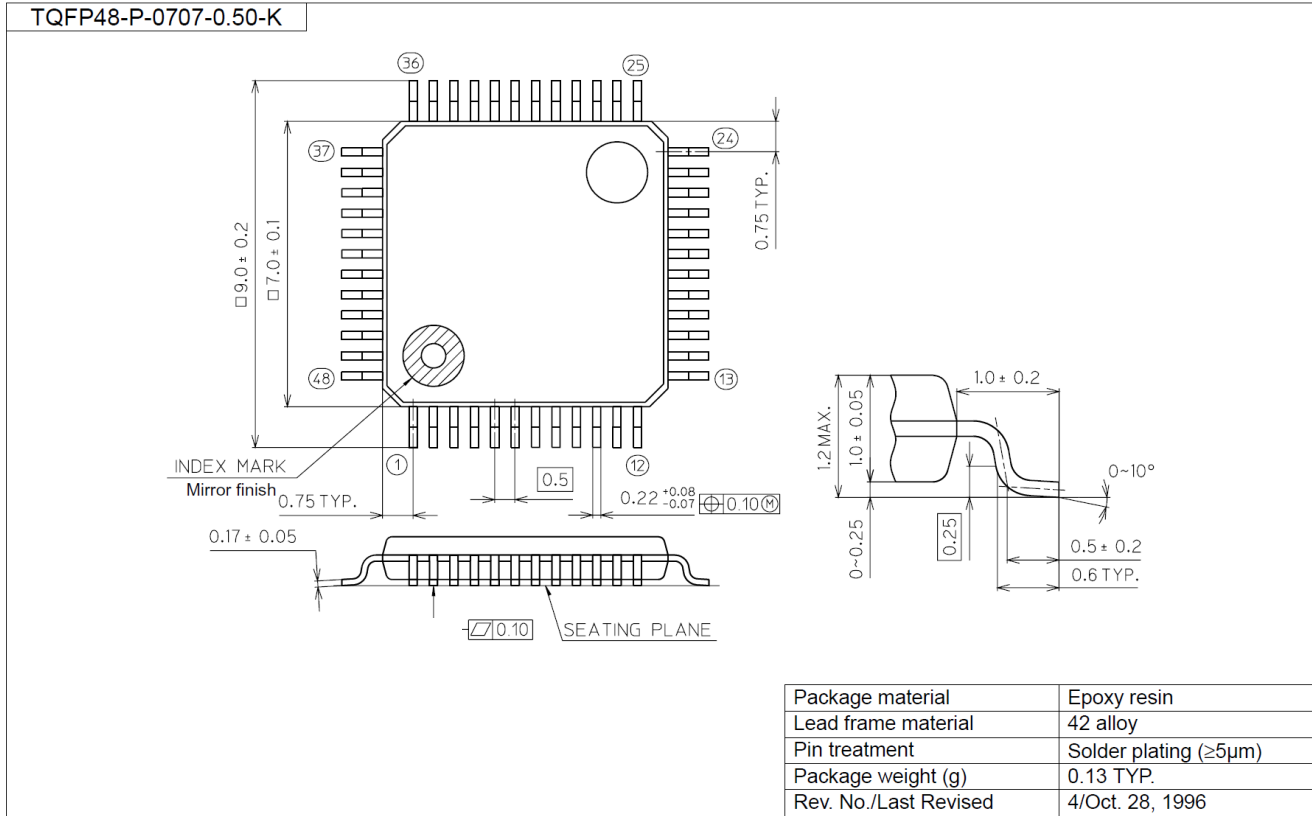

Notes for Mounting the Surface Mount Type Package

The surface mount type packages are very susceptible to heat in reflow mounting and humidity absorbed in storage. Therefore, before you perform reflow mounting, contact our responsible sales person for the product name, package name, pin number, package code and desired mounting conditions (reflow method, temperature and times).

REVISION HISTORY

Document No.	Date	Page		Description
		Previous Edition	Current Edition	
FEDL610Q482P-01	Dec.9, 2009	-	-	Formally edition 1

NOTICE

No copying or reproduction of this document, in part or in whole, is permitted without the consent of LAPIS Semiconductor Co., Ltd.

The content specified herein is subject to change for improvement without notice.

The content specified herein is for the purpose of introducing LAPIS Semiconductor's products (hereinafter "Products"). If you wish to use any such Product, please be sure to refer to the specifications, which can be obtained from LAPIS Semiconductor upon request.

Examples of application circuits, circuit constants and any other information contained herein illustrate the standard usage and operations of the Products. The peripheral conditions must be taken into account when designing circuits for mass production.

Great care was taken in ensuring the accuracy of the information specified in this document. However, should you incur any damage arising from any inaccuracy or misprint of such information, LAPIS Semiconductor shall bear no responsibility for such damage.

The technical information specified herein is intended only to show the typical functions of and examples of application circuits for the Products. LAPIS Semiconductor does not grant you, explicitly or implicitly, any license to use or exercise intellectual property or other rights held by LAPIS Semiconductor and other parties. LAPIS Semiconductor shall bear no responsibility whatsoever for any dispute arising from the use of such technical information.

The Products specified in this document are intended to be used with general-use electronic equipment or devices (such as audio visual equipment, office-automation equipment, communication devices, electronic appliances and amusement devices).

The Products specified in this document are not designed to be radiation tolerant.

While LAPIS Semiconductor always makes efforts to enhance the quality and reliability of its Products, a Product may fail or malfunction for a variety of reasons.

Please be sure to implement in your equipment using the Products safety measures to guard against the possibility of physical injury, fire or any other damage caused in the event of the failure of any Product, such as derating, redundancy, fire control and fail-safe designs. LAPIS Semiconductor shall bear no responsibility whatsoever for your use of any Product outside of the prescribed scope or not in accordance with the instruction manual.

The Products are not designed or manufactured to be used with any equipment, device or system which requires an extremely high level of reliability the failure or malfunction of which may result in a direct threat to human life or create a risk of human injury (such as a medical instrument, transportation equipment, aerospace machinery, nuclear-reactor controller, fuel-controller or other safety device). LAPIS Semiconductor shall bear no responsibility in any way for use of any of the Products for the above special purposes. If a Product is intended to be used for any such special purpose, please contact a ROHM sales representative before purchasing.

If you intend to export or ship overseas any Product or technology specified herein that may be controlled under the Foreign Exchange and the Foreign Trade Law, you will be required to obtain a license or permit under the Law.

Copyright 2008 - 2011 LAPIS Semiconductor Co., Ltd.