



ML22420MB/ML22460MB

Speech Synthesis LSI with Serial ROM Interface Including 4-Channel Mixing Function

GENERAL DESCRIPTION

ML22420 and ML22460 are voice synthesis LSIs with serial interface to the external ROM that stores voice data.

These LSIs include edit ROM, ADPCM2 decoder, 16-bit DA converter, low pass filter and monaural speaker amplifier. Also, ML22420 supports the synchronous serial interface and ML22460 supports the I2C interface.

By integrating all the functions required for voice output into a single chip, these LSIs can be more easily incorporated in compact portable devices.

- Maximum External ROM capacity: 128Mbits
- External ROM capacity and maximum vocal reproduction time:
(at the case of 4-bit OKI ADPCM2 algorithm)

External ROM capacity	Maximum vocal reproduction time (sec)		
	F _S = 4.0 kHz	F _S = 8.0 kHz	F _S = 16 kHz
128 Mbits	8,352	4,176	2,088
64 Mbits	4,176	2,088	1,044
16 Mbits	1,044	522	261

- Voice synthesis method: 4-bit OKI ADPCM2
8-bit Nonlinear PCM
8-bit PCM, 16-bit PCM
Can be specified for each phrase.
- Sampling frequency(F_S): 4.0 / 5.3 / 6.4 / 8.0 / 10.6 / 12.0 / 12.8 / 16.0 / 21.3 / 24.0 / 25.6 / 32.0 / 48.0 kHz
F_S can be specified for each phrase.
- Built-in low-pass filter and 16-bit DA converter
- Speaker driving amplifier: 0.7 W (when Z=8Ω, DV_{DD}=5 V, Ta=25°C)
2ch analog inputs (internal: 1ch, external: 1ch)
- CPU command interface: 3-wired serial clock-synchronized (ML22420)
I2C interface (ML22460)
- Maximum number of phrases: 1024 phrases from 000h to 3FFh
- Volume control: 32 levels (OFF is included) can be set by CVOL command.
50 levels (OFF is included) can be set by AVOL command.
- Repeat function: LOOP commands
- 4-channel mixing function: Available when F_S for each channel is 16kHz or less
- Master clock frequency: 4.096 MHz
- Power supply voltage: 2.7 V to 5.5 V
- Operating temperature range: -40°C to +85°C
- Package: 30-pins plastic SSOP (SSOP30-P-56-0.65-K-MC)
- Product name: ML22420, ML22460

The following table shows the differences among the other speech synthesis LSIs.

Item	MSM9841	ML2240	ML22420/460
CPU interface	Parallel	Parallel/Serial	Serial/I2C
Voice memory	external	←	←
Memory interface	8/16-bits parallel	8-bits parallel	Serial
Voice synthesis algorithm	4-bit Oki ADPCM2 8-bit nonlinear PCM 8-bit straight PCM 16-bit straight PCM	←	←
Maximum number of phrases	-	256	1024
Sampling frequency (kHz)	4.0/ 6.4/ 8.0/ 12.8/ 16.0/ 32.0	4.0/ 5.3/ 6.4/ 8.0/ 10.7/ 12.8/ 16.0	4.0/5.3/6.4/8.0/10.6/ 12.0/12.8/16.0/21.3/ 24.0/25.6/32.0/48.0
Clock frequency	4.096MHz (with a built-in crystal oscillator circuit)	←	←
D/A converter	14 bits	←	16 bits
Low-pass filter	2nd order comb. filter	FIR interpolation filter	←
Speaker driving amplifier	N.A.	N.A.	Built-in 0.7W (8Ω, DV _{DD} = 5 V)
Edit ROM function	Available	←	←
Simultaneous sound production function (mixing function)	Monaural	4-channels	←
Volume control	8 levels	29 levels	32 levels
Silence insertion	N.A.	20 ms to 1024 ms (4 ms step)	←
Repeat function	Available	←	←
Silent interval for seam during continuous playback (*1)	No (Seamless)	←	←
Power supply voltage	2.7 V to 5.5 V	←	←
Package	56-pins QFP	80-pins TQFP	30-pins SSOP

*1: Continuous playback as shown below is possible.

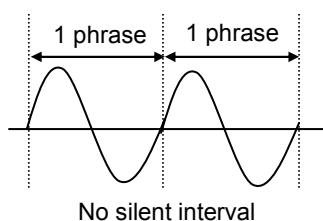

BLOCK DIAGRAMS

(ML22420MB : Synchronous serial interface)

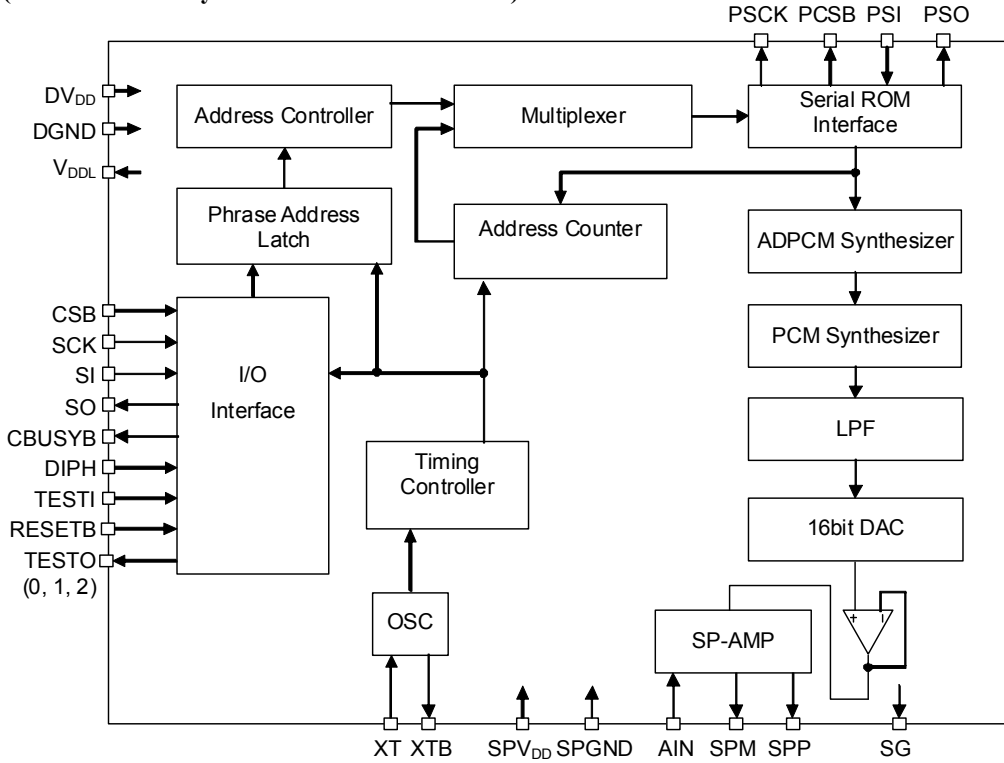

(ML22460MB : I2C interface)

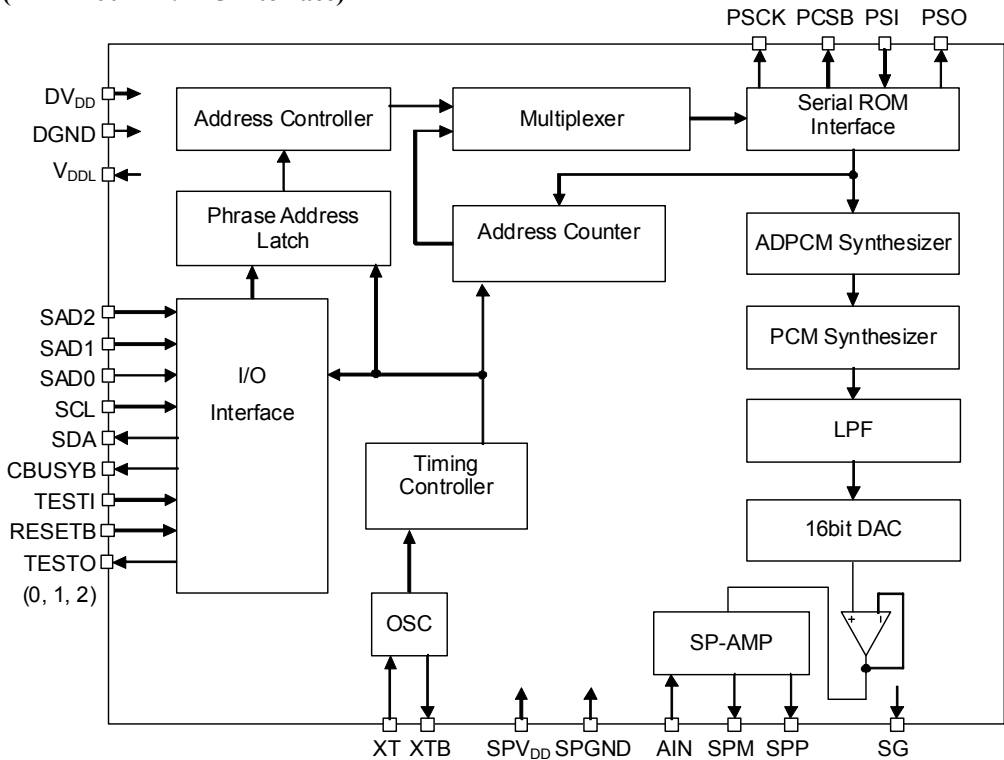

PIN CONFIGURATIONS (TOP VIEW)

(ML22420MB : Synchronous serial interface)

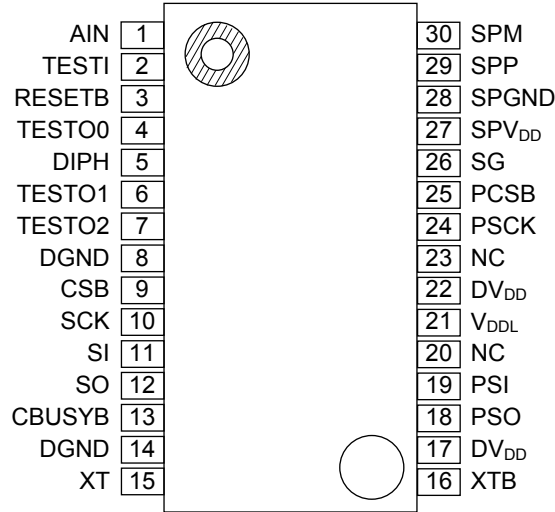

NC:No Connection

30-Pin Plastic SSOP

(ML22460MB : I2C interface)

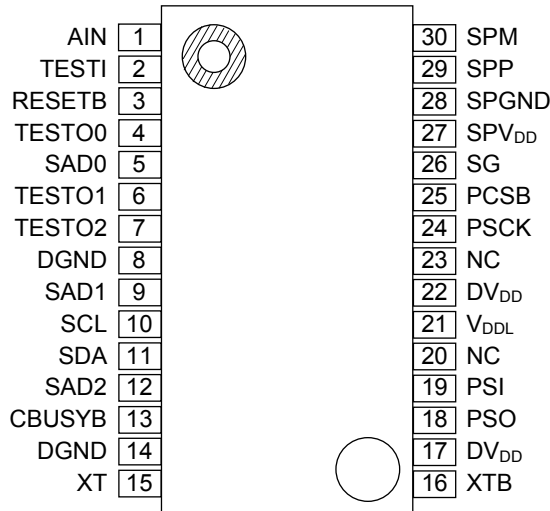

NC:No Connection

30-Pin Plastic SSOP

PIN DESCRIPTION (COMMON TO ALL PRODUCTS)

Pin	Symbol	I/O	Initial value (*1)	Description
1	AIN	I	0	Input pin for speaker amplifier.
2	TESTI	I	0	Input pin for testing. Fix this pin to "L" level (DGND level). This pin has a pull-down resistor built in.
3	RESETB	I	0 (*2)	Input pin for reset. At the "L" level, the LSI enters initial state. During reset, the entire circuitry stops and enters power down state. Input "L" level when power is supplied. After the power supply voltage is stable, drive this pin to "H" level. Then the entire circuitry can be powered up. This pin has a pull-up resistor built in.
4,6,7	TESTO (0,1,2)	O	Hi-Z	Output pins for testing. Leave these pins open.
8,14	DGND	—	—	Ground pins for logic circuitry.
13	CBUSYB	O	1	Output pin for command processing status. This pin outputs "L" level during command processing. Any command should be entered when this pin is "H" level.
15	XT	I	0	Connect to the crystal or ceramic resonator. A feedback resistor around 1 MΩ is built in between this pin and the XTB pin. Use this pin if need to use an external clock. If the resonator is used, connect it as close to this pin as possible.
16	XTB	O	1	Connect to the crystal or ceramic resonator. When to use an external clock, leave this pin open. If the resonator is used, connect it as close to this pin as possible.
17, 22	DV _{DD}	—	—	Power supply pins for logic circuitry. Connect a capacitor of 0.1μF or more between these pins and DGND pins.
18	PSO	O	1	Serial data output pin for voice ROM interface.
19	PSI	I	Hi-Z	Serial data input pin for voice ROM interface.
20,23	N.C.			Non connected pins. Leave these pins open.
21	V _{DDL}	—	—	Regulator output pin for internal logic circuitry. Connect a capacitor recommended between this pin and DGND pin.
24	PSCK	O	1	Clock output pin for voice ROM interface.
25	PCSB	O	1	Chip select output pin for voice ROM interface. At the "L" level, ROM access is available.
26	SG	—	0	Reference voltage output pin for the speaker amplifier built-in. Connect a capacitor recommended between this pin and DGND pin.
27	SPV _{DD}	—	—	Power supply pin for the speaker amplifier. Connect a bypass capacitor of 0.1μF or more between this pin and SPGND pin.
28	SPGND	—	—	Ground pin for the speaker amplifier.
29	SPP	O	0	Positive(+) output pin of the speaker amplifier built-in. Serves as the LINE output (*3), if built-in speaker amplifier is not used.
30	SPM	O	Hi-Z	Negative(-) output pin of the speaker amplifier built-in.

*1: Indicate the initial value during reset input or power down.

*2: "H" during power down.

*3: Output a voice signal before amplified by the speaker amplifier built-in.

PIN DESCRIPTION (FOR ML22420 SYNCHRONOUS SERIAL INTERFACE)

Pin	Symbol	I/O	Initial value (*1)	Description
5	DIPH	I	0	Set pin of the SCK clock edge. When this pin is "L" level, rising edge is available for input(SI) and falling edge is available for output(SO). When this pin is "H" level, falling edge is available for input(SI) and rising edge is available for output(SO).
9	CSB	I	1	Chip select pin. At the "L" level, data input/output is available.
10	SCK	I	0	Synchronous clock input pin for serial interface.
11	SI	I	0	Input pin of synchronous serial data. When the DIPH pin is "L" level, data is shifted in at the rising edges of the SCK clock pulses. When the DIPH pin is "H" level, data is shifted in at the falling edges of the SCK clock pulses.
12	SO	O	Hi-Z	Output pin of synchronous serial data. When the DIPH pin is "L" level, data is output at the falling edges of the SCK clock pulses. When the DIPH pin is "H" level, data is output at the rising edges of the SCK clock pulses. When the CSB pin is "H" level, this pin is Hi-Z state.

*1: Indicate the initial value during reset or power down.

PIN DESCRIPTION (FOR ML22460 I2C INTERFACE)

Pin	Symbol	I/O	Initial value (*1)	Description
5, 9, 12	SAD0 SAD1 SAD2	I	0	Set pin of the slave address.
10	SCL	I	0	Clock input pin for I2C serial interface. This pin should be connected to pull-up resistor.
11	SDA	IO	0	Input/output pin for I2C serial data. Use for setting the mode of write/read and writing address, writing data or reading data. This pin should be connected to pull-up resistor. (N-ch MOS) open drain, when output mode. High impedance(Hi-Z), when input mode.

*1: Indicate the initial value during reset or power down.

ABSOLUTE MAXIMUM RATINGS

(DGND = SPGND = 0 V, Ta = 25°C)

Parameter	Symbol	Condition	Rating	Unit
Power supply voltage	DV _{DD} , SPV _{DD}	—	-0.3 to +7.0	V
Input voltage	V _{IN}	—	-0.3 to DV _{DD} +0.3	V
Power dissipation	P _D		938	mW
Output short-circuit current	I _{OS}	Applies to all pins except SPM, SPP and V _{DDL} pins.	10	mA
		Applies to SPM and SPP pins.	300	mA
		Applies to V _{DDL} pin.	50	mA
Storage temperature	T _{STG}	—	-55 to +150	°C

RECOMMENDED OPERATING CONDITIONS

(DGND = SPGND = 0 V)

Parameter	Symbol	Condition	Range			Unit
Power supply voltage	DV _{DD} , SPV _{DD}	—	2.7 to 5.5			V
Operating temperature	T _{OP}	—	-40 to +85			°C
Master clock frequency	f _{OSC}	—	Min.	Typ.	Max.	MHz
			3.5	4.096	4.5	
External capacitors for crystal oscillator	Cd, Cg	—	15	30	45	pF

ELECTRICAL CHARACTERISTICS

DC Characteristics (for the 3V applications)

$DV_{DD} = SPV_{DD} = 2.7$ to 3.6 V, $DGND = AGND = 0$ V, $T_a = -40$ to $+85^\circ\text{C}$

Parameter	Symbol	Condition	Min.	Typ.	Max.	Unit
"H" input voltage	V_{IH}	—	$0.86 \times DV_{DD}$	—	DV_{DD}	V
"L" input voltage	V_{IL}	—	0	—	$0.14 \times DV_{DD}$	V
"H" output voltage 1	V_{OH1}	$I_{OH} = -1$ mA	$DV_{DD} - 0.4$	—	—	V
"H" output voltage 2 (*1)	V_{OH2}	$I_{OH} = -50$ μA	$DV_{DD} - 0.4$	—	—	V
"L" output voltage 1	V_{OL1}	$I_{OL} = 2$ mA	—	—	0.4	V
"L" output voltage 2 (*1)	V_{OL2}	$I_{OL} = 50$ μA	—	—	0.4	V
"L" output voltage 3 (*2)	V_{OL3}	$I_{OL} = 3$ mA	—	—	0.4	V
"H" input current 1	I_{IH1}	$V_{IH} = DV_{DD}$	—	—	10	μA
"H" input current 2 (*3)	I_{IH2}	$V_{IH} = DV_{DD}$	0.3	2.0	15	μA
"H" input current 3 (*4)	I_{IH3}	$V_{IH} = DV_{DD}$	2	30	200	μA
"L" input current 1	I_{IL1}	$V_{IL} = \text{GND}$	-10	—	—	μA
"L" input current 2 (*3)	I_{IL2}	$V_{IL} = \text{GND}$	-15	-2.0	-0.3	μA
"L" input current 3 (*5)	I_{IL3}	$V_{IL} = \text{GND}$	-200	-30	-2	μA
"H" output leak current 3 (*6)	I_{ILOH}	$V_{OH} = DV_{DD}$	—	—	10	μA
"L" output leak current 3 (*6)	I_{ILOL}	$V_{OL} = \text{GND}$	-10	—	—	μA
Supply current during playback	I_{DD}	$f_{OSC} = 4.096$ MHz No output load	—	—	20	mA
Power-down supply current	I_{DDS}	$T_a = -40$ to $+40^\circ\text{C}$	—	1	10	μA
		$T_a = -40$ to $+85^\circ\text{C}$	—	1	20	μA

*1: Applies to the XTB pin.

*2: Applies to the SCL and SDA pins.

*3: Applies to the XT pin.

*4: Applies to the TESTI pin.

*5: Applies to the RESETB pin.

*6: Applies to the TESTO(0, 1 and 2) pins.

DC Characteristics (for the 5V applications)
 $DV_{DD} = SPV_{DD} = 4.5 \text{ to } 5.5 \text{ V}$, $DGND = SPGND = 0 \text{ V}$, $T_a = -40 \text{ to } +85^\circ\text{C}$

Parameter	Symbol	Condition	Min.	Typ.	Max.	Unit
"H" input voltage	V_{IH}	—	$0.8 \times DV_{DD}$	—	DV_{DD}	V
"L" input voltage	V_{IL}	—	0	—	$0.2 \times DV_{DD}$	V
"H" output voltage 1	V_{OH1}	$I_{OH} = -1 \text{ mA}$	$DV_{DD} - 0.4$	—	—	V
"H" output voltage 2 (*1)	V_{OH2}	$I_{OH} = -50 \mu\text{A}$	$DV_{DD} - 0.4$	—	—	V
"L" output voltage 1	V_{OL1}	$I_{OL} = 2 \text{ mA}$	—	—	0.4	V
"L" output voltage 2 (*1)	V_{OL2}	$I_{OL} = 50 \mu\text{A}$	—	—	0.4	V
"L" output voltage 3 (*2)	V_{OL3}	$I_{OL} = 3 \text{ mA}$	—	—	0.4	V
"H" input current 1	I_{IH1}	$V_{IH} = DV_{DD}$	—	—	10	μA
"H" input current 2 (*3)	I_{IH2}	$V_{IH} = DV_{DD}$	0.8	5.0	20	μA
"H" input current 3 (*4)	I_{IH3}	$V_{IH} = DV_{DD}$	20	100	400	μA
"L" input current 1	I_{IL1}	$V_{IL} = \text{GND}$	-10	—	—	μA
"L" input current 2 (*3)	I_{IL2}	$V_{IL} = \text{GND}$	-20	-5.0	-0.8	μA
"L" input current 3 (*5)	I_{IL3}	$V_{IL} = \text{GND}$	-400	-100	-20	μA
"L" output leak current 2 (*6)	I_{ILOH}	$V_{OH} = DV_{DD}$	—	—	10	μA
"L" output leak current 3 (*6)	I_{ILOL}	$V_{OL} = \text{GND}$	-10	—	—	μA
Supply current during playback	I_{DD}	$f_{OSC} = 4.096 \text{ MHz}$ No output load	—	—	25	mA
Power-down supply current	I_{DDs}	$T_a = -20 \text{ to } +40^\circ\text{C}$	—	1	15	μA
		$T_a = -20 \text{ to } +85^\circ\text{C}$	—	1	30	μA

*1: Applies to the XTB pin.

*2: Applies to the SCL and SDA pins.

*3: Applies to the XT pin.

*4: Applies to the TESTI pin.

*5: Applies to the RESETB pin.

*6: Applies to the TESTO(0, 1 and 2) pins.

Characteristics of Analog Circuitry (for the 3V applications) $DV_{DD} = SPV_{DD} = 2.7$ to 3.6 V, $DGND = SPGND = 0$ V, $T_a = -40$ to $+85^\circ\text{C}$

Parameter	Symbol	Condition	Min.	Typ.	Max.	Unit
AIN input resistance	R_{AIN}	—	15	20	25	$k\Omega$
AIN input voltage range	V_{AIN}		—	—	$DV_{DD} \times 2/3$	Vp-p
LINE output load resistance	R_{LA}	During 1/2 DV_{DD} output	10	—	—	$k\Omega$
LINE output voltage range	V_{AO}	No output load	$DV_{DD}/6$	—	$DV_{DD} \times 5/6$	V
SG output voltage	V_{SG}	—	$0.95 \times V_{DDL}/2$	$V_{DDL}/2$	$1.05 \times V_{DDL}/2$	V
SG output resistance	R_{SG}	During power down	57	96	135	$k\Omega$
SPM, SPP output load resistance	R_{LSP}	—	8	—	—	Ω
Speaker amplifier output power	P_{SPO}	$SPV_{DD} = 3.3\text{V}$, $f = 1\text{kHz}$ $R_{SPO} = 8\Omega$, $THD \geq 10\%$	100	300	—	mW
Output offset voltage between SPM and SPP with no signal present	V_{OF}	SPIN–SPM gain = 0dB With a load of 8Ω	–50	—	+50	mV

Characteristics of Analog Circuitry (for the 5V applications) $DV_{DD} = SPV_{DD} = 4.5$ to 5.5 V, $DGND = SPGND = 0$ V, $T_a = -20$ to $+85^\circ\text{C}$

Parameter	Symbol	Condition	Min.	Typ.	Max.	Unit
AIN input resistance	R_{AIN}	—	15	20	25	$k\Omega$
AIN input voltage range	V_{AIN}		—	—	$DV_{DD} \times 2/3$	Vp-p
LINE output load resistance	R_{LA}	During 1/2 DV_{DD} output	10	—	—	$k\Omega$
LINE output voltage range	V_{AO}	No output load	$DV_{DD}/6$	—	$DV_{DD} \times 5/6$	V
SG output voltage	V_{SG}	—	$0.95 \times V_{DDL}/2$	$V_{DDL}/2$	$1.05 \times V_{DDL}/2$	V
SG output resistance	R_{SG}	During power down	57	96	135	$k\Omega$
SPM, SPP output load resistance	R_{LSP}	—	8	—	—	Ω
Speaker amplifier output power	P_{SPO}	$SPV_{DD} = 5.0\text{V}$, $f = 1\text{kHz}$ $R_{SPO} = 8\Omega$, $THD \geq 10\%$ $T_a = 25^\circ\text{C}$	500	700	—	mW
Output offset voltage between SPM and SPP with no signal present	V_{OF}	SPIN–SPM gain = 0dB With a load of 8Ω	–50	—	+50	mV

FUNCTIONAL DESCRIPTION

Synchronous Serial Command Interface (Applied to ML22420)

The CSB, SCK, SI, and SO pins are used to input the command data or to read the status. Driving the CSB pin to “L” level enables the serial CPU interface.

After the CSB pin is driven to “L” level, the command data are input through the SI pin from the MSB synchronized with the SCK clock. The command data shifts in through the SI pin at the rising or falling edge of the SCK clock pulse. Then, a command is executed at the rising or falling edge of the eighth pulse of the SCK clock.

As for status reading, status is output from the SO pin, synchronized with the SCK clock after the CSB pin is driven to “L” level.

The SCK clock edge is specified by the input level of the DIPH pin.

- When the DIPH pin is “L” level, rising edge is available for input from SI pin and falling edge is available for output from SO pin.
- When the DIPH pin is “H” level, falling edge is available for input from SI pin and rising edge is available for output from SO pin.

It is possible to input command data, even if the CSB pin is fixed by “L” level. However, if unexpected pulses caused by noise are induced through the SCK pin, SCK clock pulses are incorrectly counted, causing a failure in normal recognition of command. Then it is recommended that the CSB pin is “L” level only for command input.

The count of the SCK clock pulse is initialized when the CSB pin goes to “H” level.

Command Data Input or Status Read Timing

- When DIPH pin is “L” level

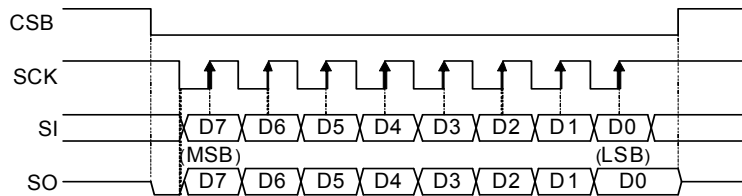

- When DIPH pin is “H” level

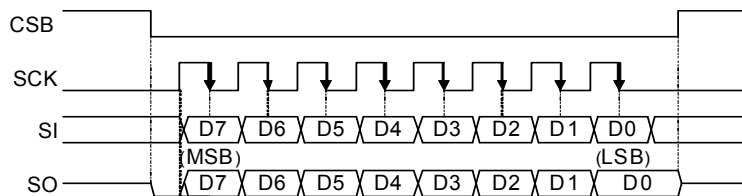

The following table shows the contents of each data output at a status read.

bit	Output status signal
MSB	Channel 4 BUSYB output (BUSYB3)
7SB	Channel 3 BUSYB output (BUSYB2)
6SB	Channel 2 BUSYB output (BUSYB1)
5SB	Channel 1 BUSYB output (BUSYB0)
4SB	Channel 4 NCR output (NCR3)
3SB	Channel 3 NCR output (NCR2)
2SB	Channel 2 NCR output (NCR1)
LSB	Channel 1 NCR output (NCR0)

The BUSYB output is “L” level when a command is being processed or the playback of a particular channel is going on. In other states, the BUSYB output is “H” level. The NCR output is “L” level when a command is being processed or particular channel is in standby for playback. In other states, the NCR output is “H” level.

I2C Command Interface (Applied to ML22460)

The I2C Interface built-in is an serial interface (: slave side) that is compliant with I2C bus specification. It supports Fast mode and enables data transmission/reception at 400 kbps. The SCL and SDA pins are used to input the command data or to read the status. Pins (:SAD0, 1 and 2) are used to set the slave address. Pull-up resistor should be connected to SCL pin and SDA pin.

For the master on the I2C bus to communicate with this device (: slave), input the slave address with the first seven bits after setting the start condition. The upper three bits of the slave address can be set using the SAD0 to 2 pins. The eighth bit of slave address is used to set the direction (: write or read) of communication. If the eighth bit is “0” level, it is write mode from master to slave. And, if the eighth bit is “1” level, it is read mode from master.

The communication is made in the unit of byte. And acknowledge is needed for each byte.

The protocol of I2C communication is shown below.

- Command flow at the data write
 - Start condition
 - Slave address +W(0)
 - Write address (ex. 1st byte of the command)
 - Write data (ex. 2nd byte of the command)
 - STOP condition

• Data write timing

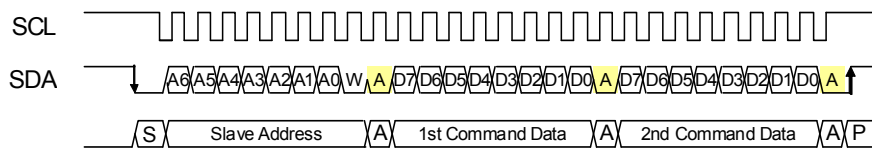

- Command flow at the data read
 - Start condition
 - Slave address +R(1)
 - Read data (ex. Status read)
 - STOP condition

• Data read timing

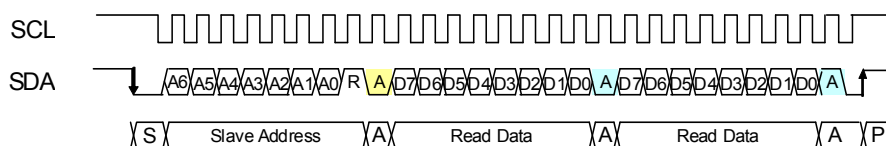

Setting of the slave address using the SAD0 to 2 pins

SAD2	SAD1	SAD0	Lower 4 bits
0	0	0	0101
0	0	1	0101
0	1	0	0101
0	1	1	0101
1	0	0	0101
1	0	1	0101
1	1	0	0101
1	1	1	0101

The following table shows the contents of each data output at the status read. Status is updated by the RDSTAT command, therefore, be sure to input the RDSTAT command in order to read status.

bit	Output status signal
MSB	Channel 4 BUSYB output (BUSYB3)
7SB	Channel 3 BUSYB output (BUSYB2)
6SB	Channel 2 BUSYB output (BUSYB1)
5SB	Channel 1 BUSYB output (BUSYB0)
4SB	Channel 4 NCR output (NCR3)
3SB	Channel 3 NCR output (NCR2)
2SB	Channel 2 NCR output (NCR1)
LSB	Channel 1 NCR output (NCR0)

The BUSYB signal is “L” level when either a command is being processed or the playback of a particular channel is going on. In other states, the BUSYB signal is “H” level. The NCR signal is “L” level when either a command is being processed or a particular channel is in standby for playback. In other states, the NCR signal is “H” level.

Command List

Each command is configured by the unit of byte (:8-bits). The following commands, AMODE, AVOL, FADR, PLAY, MUON and CVOL, use two bytes.

Command	D7	D6	D5	D4	D3	D2	D1	D0	Description
PUP	0	0	0	0	0	0	0	0	Power-up command. shift from the power down state to the command waiting state
PDWN	0	0	1	0	0	0	0	0	Power-down command. shift from the command waiting state to the power down state
RDSTAT	1	0	1	1	0	0	0	0	Status read command. Read the command status of each channel.
AMODE	0	0	0	0	0	1	0	0	Control command of analog circuitry. Set operation of power-up/dpwn and input/output.
	FAD	DAG1	DAG0	AIG1	AIG0	DAEN	SPEN	POP	
PLAY	0	1	0	0	F9	F8	C1	C0	Playback start command. Set phrase address using F9 to F0 bits for each channel. Set channel using C1 and C0 bits.
	F7	F6	F5	F4	F3	F2	F1	F0	
STOP	0	1	1	0	CH3	CH2	CH1	CH0	Playback stop command. Can be set for each channel.
FADR	0	0	1	1	F9	F8	C1	C0	Set command of playback phrase. Can be set for each channel. Use START command to start.
	F7	F6	F5	F4	F3	F2	F1	F0	
START	0	1	0	1	CH3	CH2	CH1	CH0	Playback start command without phrase spec. Use FADR command to set phrase. Can start playback on multiple channels simultaneously. After played back by PLAY command, the same phrase can be played back with this command.
MUON	0	1	1	1	CH3	CH2	CH1	CH0	Silence insertion command. Set the silent time length for each channel using M7 to M0 bits in the 2nd byte.
	M7	M6	M5	M4	M3	M2	M1	M0	
SLOOP	1	0	0	0	CH3	CH2	CH1	CH0	Set command of repeat playback. Setting is enabled during playback. Can be specified for each channel.
CLOOP	1	0	0	1	CH3	CH2	CH1	CH0	Stop command of repeat playback. Can be specified for each channel. Also, repeat playback is released by STOP command automatically.
CVOL	1	0	1	0	CH3	CH2	CH1	CH0	Volume control command. Set volume for each channel using CV4 to CV0 bits in the 2nd byte.
	0	0	0	CV4	CV3	CV2	CV1	CV0	
AVOL	0	0	0	0	1	0	0	0	Analog volume control command. Set volume after channel mixing using AV5 to AV0 bits.
	0	0	AV5	AV4	AV3	AV2	AV1	AV0	

Voice Synthesis Algorithm

Four types of voice synthesis algorithm are supported. They are OKI 4-bit ADPCM2, OKI 8-bit non-linear PCM, 8-bit straight PCM and 16-bit straight PCM. Select the best one according to the characteristics of playback voice.

The following table shows key features of each algorithm.

Voice synthesis algorithm	Applied waveform	Feature
OKI 4-bit ADPCM2	Normal voice waveform	Up version of LAPIS Semiconductor's specific voice synthesis algorithm (:OKI 4-bit ADPCM). Voice quality is improved.
OKI 8-bit Nonlinear PCM	Waveform including high frequency signals (sound effect, etc.)	Algorithm which plays back mid-range of waveform as 10-bit equivalent voice quality.
8-bit straight PCM		Normal 8-bit PCM algorithm.
16-bit straight PCM		Normal 16-bit PCM algorithm,

Memory Allocation and Creating Voice Data

The ROM is partitioned into four data areas: voice (i.e., phrase) control area, test area, voice area, and edit ROM area.

The voice control area manages the voice data in the ROM. It contains data for controlling the start/stop addresses of voice data for 1,024 phrases, use/non-use of the edit ROM function and so on.

The test area contains data for testing.

The voice area contains actual waveform data.

The edit ROM area contains data for effective use of voice data. For the details, refer to the section of “Edit ROM Function.”

The edit ROM area is not available if the edit ROM is not used.

The ROM data is created using a dedicated tool.

Configuration of ROM data

0x00000	Voice control area (Fixed 64 Kbits)
0x01FFF	
0x02000	Test area
0x0205F	
0x02060	Voice area
max: 0xFFFFFFF	
max: 0xFFFFFFF	
	Edit ROM area Depends on creation of ROM data.

Playback Time and Memory Capacity

The playback time depends on the memory capacity, sampling frequency, and playback method.

The equation to know the playback time is shown below. But this is not applied if the edit ROM function is used.

$$\text{Playback time [sec]} = \frac{(\text{Memory capacity} - 64) \text{ [Kbit]} \times 1.024}{\text{Sampling frequency [kHz]} \times \text{Bit length}}$$

(Bit length is 4 at the 4-bit ADPCM2 and 8/16 at the PCM.)

Example) In the case that the sampling frequency is 16 kHz, algorithm is 4-bit ADPCM2 and ROM capacity is 16 Mbits, the playback time is approx. 261 seconds, as shown below.

$$\text{Playback time} = \frac{(16,000 \times 1.024 - 64) \times 1.024}{16 \times 4} \cong 261 \text{ [sec]}$$

Edit ROM Function

The edit ROM function makes it possible to play back multiple phrases in succession. The following functions are set using the edit ROM function:

- Continuous playback: There is no limit to set the number of times of continuous playback. It depends on the memory capacity only.
- Silence insertion: 20ms to 1,024 ms

It is possible to use voice ROM effectively to use the edit ROM function. Below is an example of the ROM structure, case of using the edit ROM function.

Example 1) Phrases using the Edit ROM Function

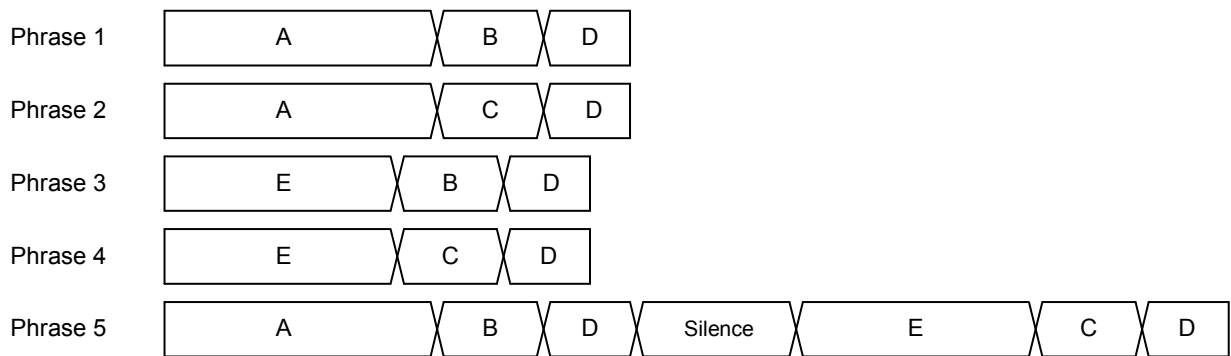

Example 2) Structure of the ROM that contents of example 1 are stored

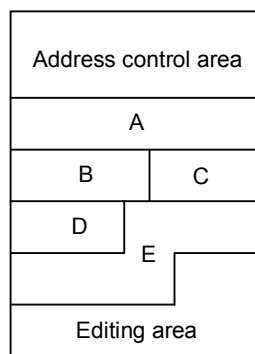

Mixing Function

It is possible to perform mixing of four channels simultaneously. And also, it is possible to specify PLAY, STOP, and CVOL commands for each channel respectively. The mixing function is available if the sampling frequency (F_s) is 16 kHz or less.

- Precautions for Waveform Clamp

Adjust the volume of each channel using the CVOL command, if the waveform clamp is increased by channel mixing.

APPLICATION CIRCUIT

ML22420: $DV_{DD}=SPV_{DD}=V_{DD}$

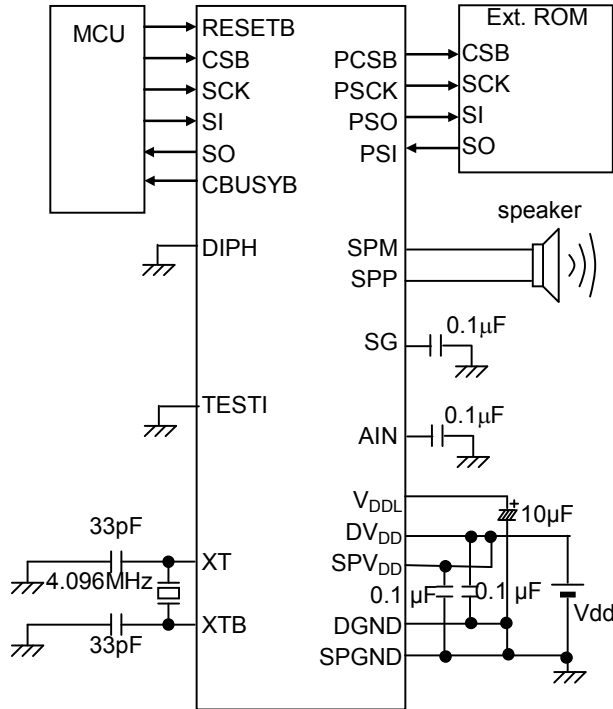

ML22460: $DV_{DD}=SPV_{DD}=V_{DD}$

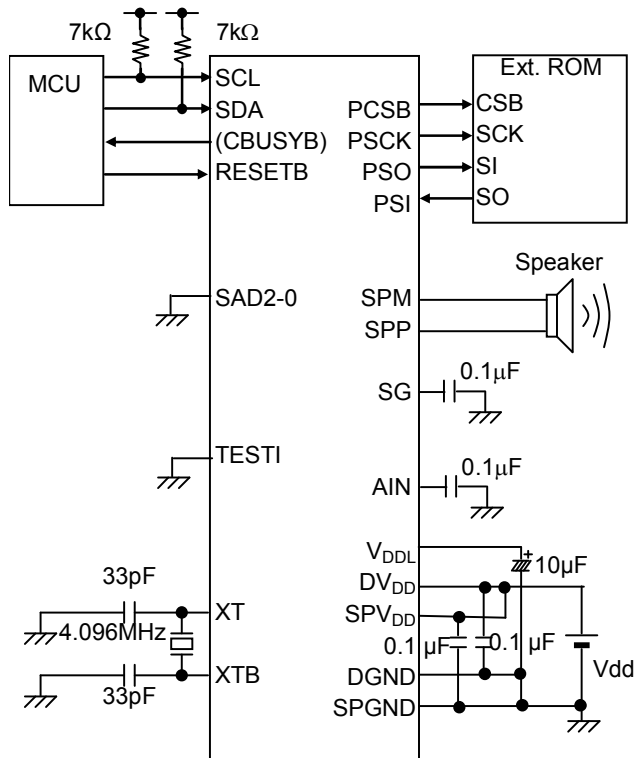

PACKAGE DIMENSIONS

(Unit: mm)

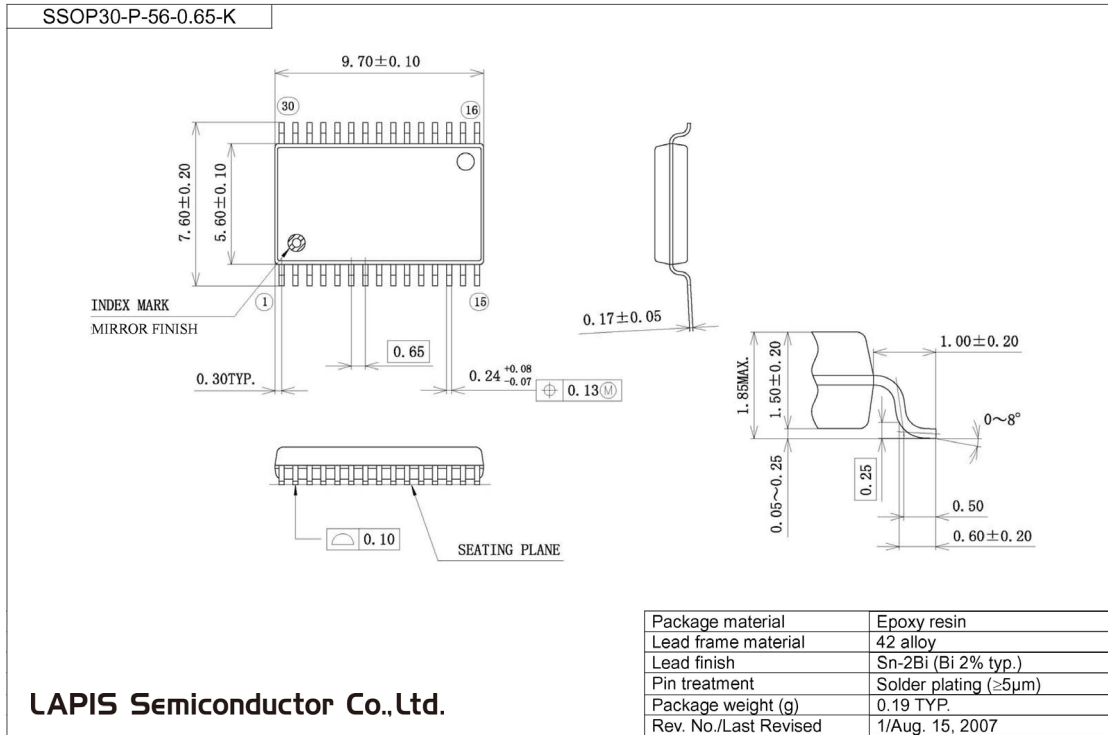

Notes for Mounting the Surface Mount Type Package:

The surface mount type packages are very susceptible to heat in reflow mounting and humidity absorbed in storage. Therefore, before you perform reflow mounting, contact ROHM's responsible sales person for the product name, package name, pin number, package code and desired mounting conditions (reflow method, temperature and times).

NOTICE

No copying or reproduction of this document, in part or in whole, is permitted without the consent of LAPIS Semiconductor Co., Ltd.

The content specified herein is subject to change for improvement without notice.

The content specified herein is for the purpose of introducing LAPIS Semiconductor's products (hereinafter "Products"). If you wish to use any such Product, please be sure to refer to the specifications, which can be obtained from LAPIS Semiconductor upon request.

Examples of application circuits, circuit constants and any other information contained herein illustrate the standard usage and operations of the Products. The peripheral conditions must be taken into account when designing circuits for mass production.

Great care was taken in ensuring the accuracy of the information specified in this document. However, should you incur any damage arising from any inaccuracy or misprint of such information, LAPIS Semiconductor shall bear no responsibility for such damage.

The technical information specified herein is intended only to show the typical functions of and examples of application circuits for the Products. LAPIS Semiconductor does not grant you, explicitly or implicitly, any license to use or exercise intellectual property or other rights held by LAPIS Semiconductor and other parties. LAPIS Semiconductor shall bear no responsibility whatsoever for any dispute arising from the use of such technical information.

The Products specified in this document are intended to be used with general-use electronic equipment or devices (such as audio visual equipment, office-automation equipment, communication devices, electronic appliances and amusement devices).

The Products specified in this document are not designed to be radiation tolerant.

While LAPIS Semiconductor always makes efforts to enhance the quality and reliability of its Products, a Product may fail or malfunction for a variety of reasons.

Please be sure to implement in your equipment using the Products safety measures to guard against the possibility of physical injury, fire or any other damage caused in the event of the failure of any Product, such as derating, redundancy, fire control and fail-safe designs. LAPIS Semiconductor shall bear no responsibility whatsoever for your use of any Product outside of the prescribed scope or not in accordance with the instruction manual.

The Products are not designed or manufactured to be used with any equipment, device or system which requires an extremely high level of reliability the failure or malfunction of which may result in a direct threat to human life or create a risk of human injury (such as a medical instrument, transportation equipment, aerospace machinery, nuclear-reactor controller, fuel-controller or other safety device). LAPIS Semiconductor shall bear no responsibility in any way for use of any of the Products for the above special purposes. If a Product is intended to be used for any such special purpose, please contact a ROHM sales representative before purchasing.

If you intend to export or ship overseas any Product or technology specified herein that may be controlled under the Foreign Exchange and the Foreign Trade Law, you will be required to obtain a license or permit under the Law.