



ML22Q340/340/Q341/341

LAPIS Semiconductor ADPCM Speech Synthesis LSI

GENERAL DESCRIPTION

The ML22340/ML22Q340/ML22341/ML22Q341, which include mask ROM and Flash memory for storing speech data, respectively, are speech synthesis LSIs which can controll speech playback utilizing an event input system. It includes speaker amplifier and 16bit DA Converter, so it is possible to have high quality sound and solution for playback with 1chip..

FEATURES

- Playback Time

Product Name	Capasitance of ROM(bit)	Maximum Playback time(s) (Fsam=8.0kHz)		
		HQ-ADPCM	4bitADPCM2	16bitPCM
ML22Q340/340	640K	—	20	5
ML22Q341/341	896K	35	28	7

- Speech sysnthesis system: 4-bit ADPCM2
8-bit/16-bit straight PCM system
8-bit nonlinear PCM system
HQ-ADPCM (*1) (ML22Q341/341)
(can be specified for each phrase)
- Speech ROM capacity ML22340: 640-Kbit Mask ROM
ML22Q340: 640-Kbit Flash
ML22341: 896-Kbit Mask ROM
ML22Q341: 896-Kbit Flash
- Sampling frequency: 8.0/16.0 /32.0kHz, 6.4/12.8/25.6 kHz/, 10.7/21.3 kHz
(fsam can be specified in units of phrase)
- Analog output: Built-in 16-bit DA converter
- Interface: Event input system (built-in noise elimination function)
- Sequencer output function: 16 types
- Maximum event count: 30 events
- Input pin setting: High-impedance input (CMOS input), pull-down input, or pull-up input is selectable based on ROM data
- Output pin setting: High-impedance output, CMOS output, Pch open drain output, Nch open drain output, or LED drive is selectable based on ROM data
- Source oscillation frequency: 4.096 MHz (Typ.)
- Power supply voltage: 2.3V to 5.5V
- Flash memory rewrite cycles: 80 times (ML22Q340/Q341)
- Operating temperature range: -40°C to +85°C
- Package: 30-pin plastic SSOP (SSOP30-56-0.65-6K)
48-pin plastic TQFP (TQFP48-0707-0.50-K) TBD
- Product name: ML22340-xxxMB (xxx: ROM code number)
ML22341-xxxMB (xxx: ROM code number)
ML22Q340-NNNMB/ML22Q340-xxxMB (xxx: ROM code number)
ML22Q341-NNNMB/ML22Q341-xxxMB (xxx: ROM code number)

(*1)  HQ-ADPCM is audio compression technology featuring high-quality sound. It was developed by "Ky's". "Ky's" is a registered trademark of Kyushu Institute of Technology, one of the national universities in Japan.

DESCRIPTION OF FUNCTIONS

Event Activation

Power-down is released by the change in the input signal to the EVIN0-4 pins and the event number specified by the EVIN0-4 pins in time t_{CHT} is internally captured and the event execution according to the number is started.

Disconnection Detection

Set the event1 (EVIN0="H", EVIN1-4="L") , operate the disconnection detection. If disconnection detection, the "ERR" pin output "H". And the 100ms "H" pulse is output right after the event start.
During the event operating, the disconnection detection can't be operated.

Thermal Detection

In the case of setting the thermal detection mode, if higher temperature than the judgement temperature, the "ERR" pin output "H".

Edit Phrase

Two or more voice phrases are joined and it can be played continuously. Moreover, the silent section can be inserted between voice phrases.

Setting of Mask Option

The following table shows the items which can be set by using the Mask option (ROM data):

Parameter	Setting value
Setting of the internal speaker amplifier	Use or unuse of the internal speaker amplifier selectable
Setting of thermal detection	Use or unuse of thermal detection selectable
Setting of judgement temperature	150°C or 125°C or 100°C selectable
EVIN0-4 pin input setting	High-impedance input (CMOS input), pull-up input, or pull-down input selectable (EVIN0 pin can specify only high-impedance input and pull-up input)
Setting of the initial value of SEQ0-6 pin output	“L” output, or “H” output state selectable (SEQ0 pin can specify only the “L” output)
Setting of SEQ0-6 pin output	CMOS output, Nch open drain, Pch open drain, high-impedance or LED drive pin selectable (SEQ0 pin can specify only the CMOS output)
Setting of use or unuse of SEQ0-6 pins	Use or unuse of the SEQ output of SEQ0-6 pins selectable (SEQ0 pin can specify only the “use”)
Speech synthesis system	4-bit ADPCM/2/8-bit/16-bit straight PCM system 8-bit nonlinear PCM system HQ-ADPCM (apply to ML22Q341/341)
Sampling frequency	8.0/16.0 /32.0kHz, 6.4/12.8/25.6 kHz/, 10.7/21.3 kHz
Event execution mode	Play once mode, scheduled play mode and change immediately mode can be selected for each execution event.
Setting of the SEQ output pattern of SEQ0-6 pins	SEQ pattern: 01h to 10h selectable SEQ pattern 01h to 08h : Level Output SEQ pattern 09h to 0Ch : Pulse Output SEQ pattern 0Dh to 10h : Edit silent/sound detection output with edit playback
Transfer time for pop noise elimination, play start, and power down: WS1 ~ WS4	0 to 1020 ms ((00h~FFh)×4ms) selectable
Setting of the count of Pulse output of SEQ output pattern	1 to 256 times ((00h~FFh)+1 times) output selectable
Delay time / Pulse width of SEQ output pattern: t _{SEQD} / t _{SEQW}	4 to 1024 ms ((00h~FFh)×4ms+4ms) selectable

And volume setting is as follows.

Setting value	Volume [dB]	Setting value	Volume [dB]	Setting value	Volume [dB]
00h	+2.98	0Ah	-0.41	15h	-6.87
01h	+2.70	0Bh	-0.83	16h	-7.79
02h	+2.40	0Ch	-1.28	17h	-8.82
03h	+2.10	0Dh	-1.75	18h	-9.99
04h	+1.78	0Eh	-2.25	19h	-11.34
05h	+1.45	0Fh	-2.77	1Ah	-12.94
06h	+1.11	10h	-3.34	1Bh	-14.90
07h	+0.76	11h	-3.94	1Ch	-17.44
08h	+0.39	12h	-4.58	1Dh	-21.04
09h	+0.00	13h	-5.28	1Eh	-27.31
		14h	-6.04	1Fh	OFF

Event contents

There are three kinds of event contents, Stop (00h), Disconnection Detection (01h), and Play (02h~1Fh), as follows.

EVENT No.	Input pattern					Contents
	EVIN4	EVIN3	EVIN2	EVIN1	EVIN0	
00h	L	L	L	L	L	Stop
01h	L	L	L	L	H	Disconnection Detection
02h	L	L	L	H	L	Play
03h	L	L	L	H	H	↑
04h	L	L	H	L	L	↑
05h	L	L	H	L	H	↑
06h	L	L	H	H	L	↑
07h	L	L	H	H	H	↑
:	:	:	:	:	:	:
:	:	:	:	:	:	:
18h	H	H	L	L	L	↑
19h	H	H	L	L	H	↑
1Ah	H	H	L	H	L	↑
1Bh	H	H	L	H	H	↑
1Ch	H	H	H	L	L	↑
1Dh	H	H	H	L	H	↑
1Eh	H	H	H	H	L	↑
1Fh	H	H	H	H	H	↑

BLOCK DIAGRAM

ML22Q340-NNN/ML22Q341-NNN

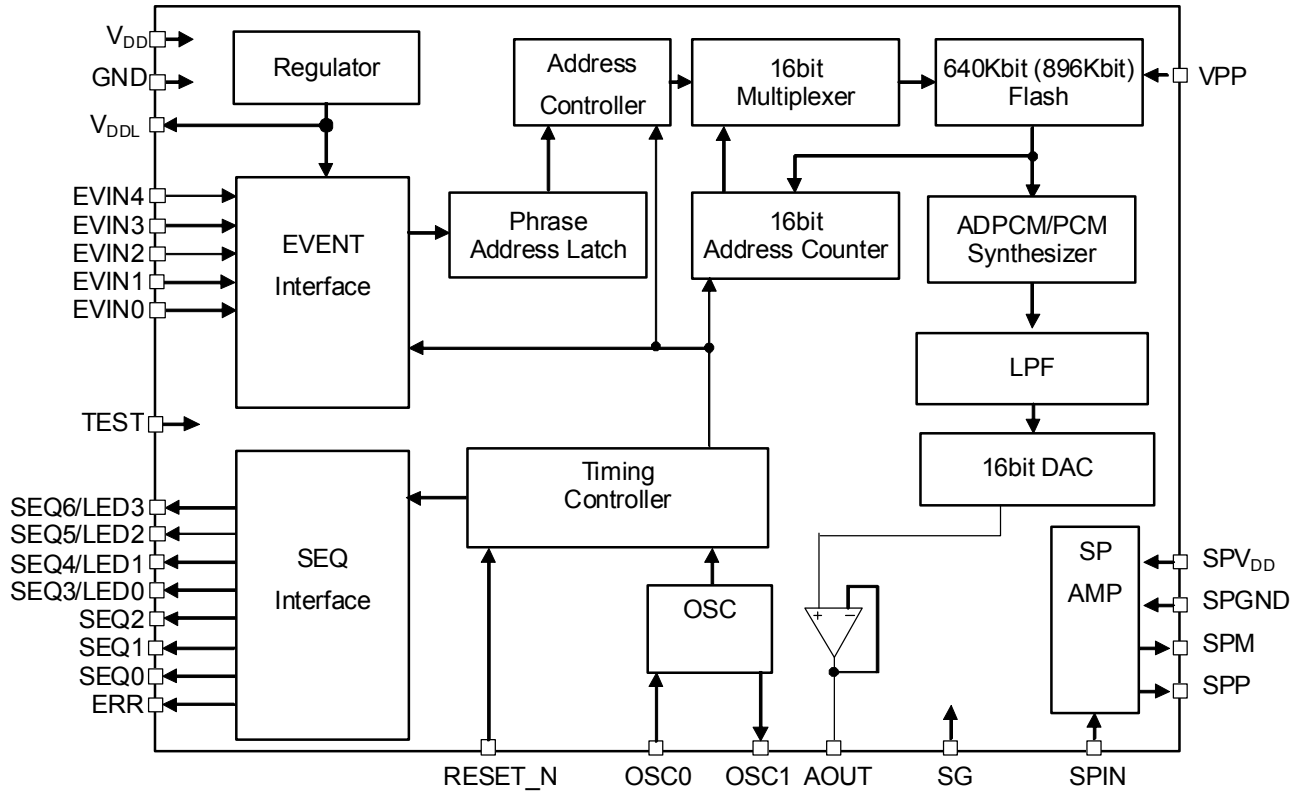

():Applies to ML22Q341

BLOCK DIAGRAM

ML22340-xxx/ML22341-xxx

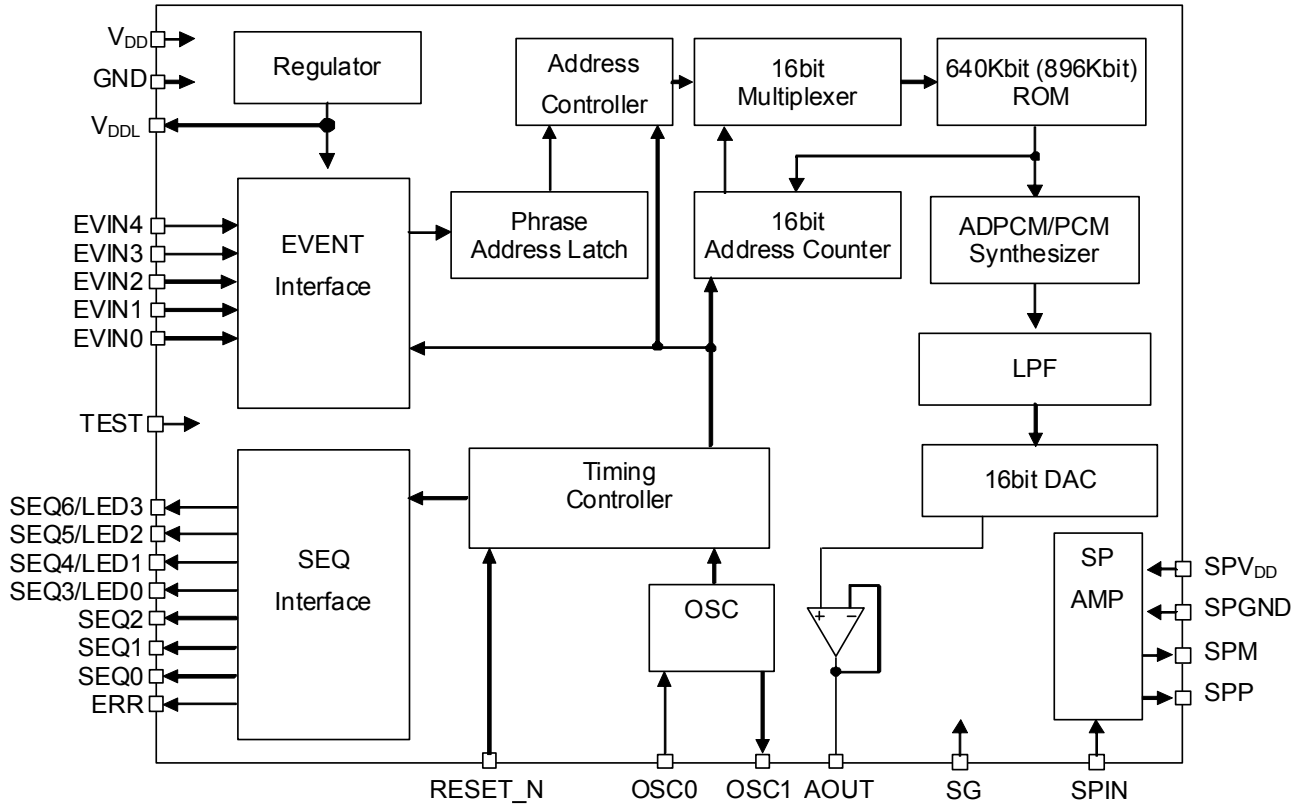

() : Applies to ML22341

PIN CONFIGURATION (TOP VIEW)

ML22Q340-NNNMB/ML22Q341-NNNMB

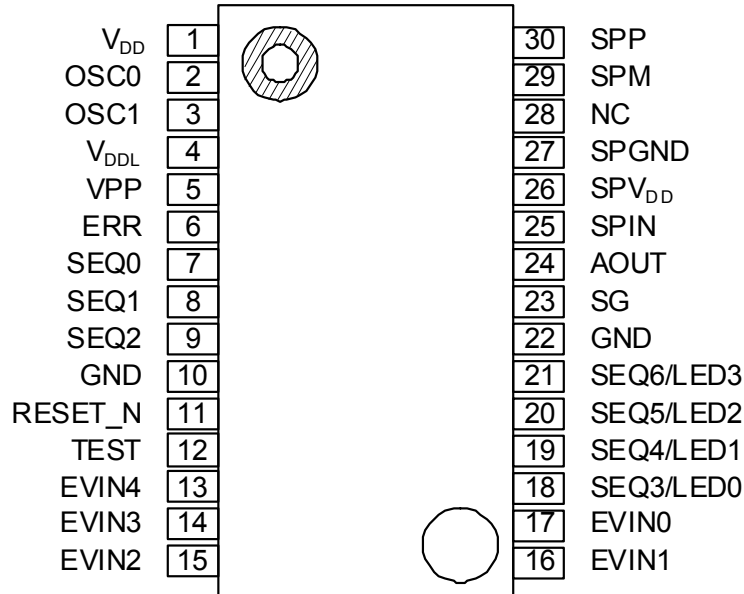

NC: Unused pin

30-pin Plastic SSOP

ML22340-xxxMB/ML22341-xxxMB

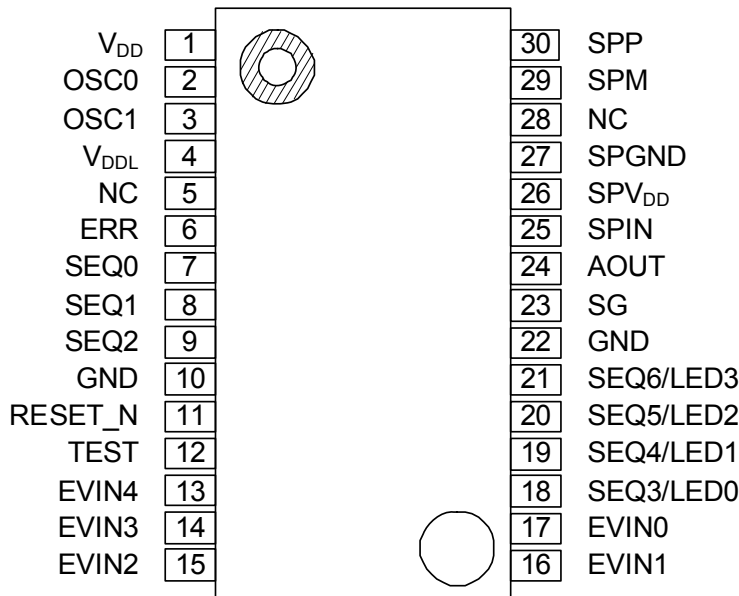

NC: Unused pin

30-pin Plastic SSOP

PIN DESCRIPTIONS

Pin No.	symbol	I/O	Description
11	RESET_N	I	Place this pin at a "L" level when powered on. After the supply voltage is settled, place this pin at a "H" level.
17 16 15 14 13	EVIN0 EVIN1 EVIN2 EVIN3 EVIN4	I	Event specifying input pins. Event execution or stop can be performed by changes in the input signals to the activation pins set by the EVIN0 pin or Mask option Set the unused pins to be pulled up or pulled down. And the SEQ0 pin can specify only the SEQ pattern 6.
12	TEST	I	Input pin for testing. Fix this pin at a "L" level (GND level).
2	OSC0	I	Pin for connecting a crystal or a ceramic vibrator. A feed back resistor (about 1 MΩ) is included between OSC0 and OSC1 pins. When a vibrator is used, place it as close to the LSI as possible.
3	OSC1	O	Pin for connecting a crystal or a ceramic vibrator. When a vibrator is used, place it as close to the LSI as possible.
6	ERR	O	Error output pin for thermal detection and disconnection detection. If disconnection detection or a higher temperature than the judgment temperature is detected, this pin output "H". Setting event 1, operate the disconnection detection. And the 100ms "H" pulse is output right after the event start.
7 8 9	SEQ0 SEQ1 SEQ2	O	Sequencer output pins. This pin is output SEQ pattern 01h~10h based on ROM data. The SEQ patterns (01h to 10h) set by Mask option are output. And the SEQ0 pin can specify only the SEQ pattern 6.
18 19 20 21	SEQ3/LED0 SEQ4/LED1 SEQ5/LED2 SEQ6/LED3	O	Sequencer output pins. These pins can drive LED. The patterns set by Mask option are output.
24	AOUT	O	Playback signal output pin. When you use built-in speaker amplifier, connect with the SPIN pin.
5	VPP *Note 1	—	Power supply pin for rewriting Flash memory. Fix this pin to GND except when rewriting Flash memory.
1	V _{DD}	—	Digital power supply pin. Connect a capacitor of 0.1 μF or more between this pin and GND.
4	V _{DDL}	—	Output pin of the regulator for the internal logic power supply. Connect a electrolytic capacitor of 10 uF or more and a ceramic capacitor of 0.1 μF or more between the V _{DDL} and GND pins.
10,22	GND	—	Digital ground pin.
27	SPGND	—	Speaker amplifier ground pin.
26	SPV _{DD}	—	Speaker amplifier power supply pin.
25	SPIN	I	Analog input pin of internal speaker amplifier.
23	SG	O	Built-in speaker amplifier's reference voltage output pin. Connect a capacitor of 0.1 μF or more between this pin and GND.
30	SPP	O	Positive output pin of the built-in speaker amplifier.
29	SPM	O	Negative output pin of the built-in speaker amplifier.

Notes: 1. Applies to ML22Q340-NNN / ML22Q341-NNN.

ABSOLUTE MAXIMUM RATINGS

(GND = SPGND = 0 V)

Parameter	Symbol	Condition	Rating	Unit
Digital power supply voltage	V _{DD}	Ta = 25 °C	-0.3 to +7.0	V
Speaker power supply voltage	SPV _{DD}		-0.3 to +7.0	V
Internal logic power supply voltage	V _{DDL}		-0.3 to +3.6	V
Flash power supply voltage (Note 1)	V _{PP}		-0.3 to +9.5	V
Input voltage	V _{IN}	Ta = 25 °C When JEDEC 2-layer board is mounted	-0.3 to V _{DD} +0.3	V
Power dissipation	P _D	Ta = 25 °C	861	mW
Output short current	I _{SC1}	except LED drive pin, Ta = 25 °C	-12 to +11	mA
	I _{SC2}	LED drive pin, Ta = 25 °C	-12 to +20	mA
Storage temperature	T _{STG}	—	-55 to +150	°C

Note 1: Applies to the ML22Q340-NNN/ML22Q341-NNN.

RECOMMENDED OPERATING CONDITIONS

(GND = SPGND = 0 V)

Parameter	Symbol	Condition	Range			Unit
			Min.	Typ.	Max.	
Digital power supply voltage	V _{DD}	—	2.3 to 5.5			V
		ML22Q340 / ML22Q341 read	2.3 to 5.5			
		ML22Q340 / ML22Q341 write	2.7 to 5.5			
Speaker power supply voltage	SPV _{DD}	—	2.3 to 5.5			V
Flash power supply voltage	V _{PP}	ML22Q340 / ML22Q341 write	7.7 to 8.3			V
Flash memory rewrite cycles	N	ML22Q340 / ML22Q341	80			—
Operating temperature	T _{OP1}	ML22340 / ML22341	-40 to +85			°C
	T _{OP2}	ML22Q340 / ML22Q341 read	-40 to +85			
	T _{OP3}	ML22Q340 / ML22Q341 write	0 to +40			
Source oscillation frequency	f _{OSC}	—	Min.	Typ.	Max.	MHz
			3.5	4.096	4.5	

ELECTRICAL CHARACTERISTICS

DC Characteristics

$V_{DD} = SPV_{DD} = 2.3 \text{ to } 5.5 \text{ V}$, $GND = SPGND = 0 \text{ V}$, $T_a = -40 \text{ to } +85^\circ\text{C}$

Parameter	Symbol	Condition	Min.	Typ.	Max.	Unit
“H” input voltage	V_{IH}	—	$0.7 \times V_{DD}$	—	V_{DD}	V
“L” voltage	V_{IL}	—	0	—	$0.3 \times V_{DD}$	V
“H” output voltage 1	V_{OH1}	$I_{OH} = -0.5 \text{ mA}$ CMOS output, Pch open drain selected	$V_{DD} - 0.5$	—	—	V
“H” output voltage 2	V_{OH2}	$I_{OH} = -100 \mu\text{A}$ OSC2 pin	$V_{DD} - 0.5$	—	—	V
“L” output voltage 1	V_{OL1}	$I_{OL} = 0.5 \text{ mA}$ CMOS output, Nch open drain selected	—	—	0.5	V
“L” output voltage 2	V_{OL2}	$I_{OL} = 100 \mu\text{A}$ OSC1 pin	—	—	0.5	V
“L” output voltage 3	V_{OL4}	$I_{OL} = 8 \text{ mA}$, $V_{DD} \geq 2.3\text{V}$ LED mode selected	—	—	0.5	V
“H” input current 1	I_{IH1}	$V_{IH} = V_{DD}$ High-impedance input selected	—	—	1	μA
“H” input current 2	I_{IH2}	$V_{IH} = V_{DD}$ TEST pin	0.02	0.3	1.5	mA
“H” input current 3	I_{IH3}	$V_{IH} = V_{DD}$ Pull-down input selected	2	30	250	μA
“L” input current 1	I_{IL1}	$V_{IL1} = GND$ High-impedance input selected	-1	—	—	μA
“L” input current 2	I_{IL2}	$V_{IL} = GND$ RESET_N pin	-1.5	-0.3	-0.02	mA
“L” input current 3	I_{IL3}	$V_{IH} = V_{DD}$ Pull-up input selected	-250	-30	-2	μA
Supply current during operate	I_{DD1}	Non-loaded output $V_{DD} = SPV_{DD} = 3.0\text{V}$	—	2.5	12	mA
	I_{DD2}	Non-loaded output $V_{DD} = SPV_{DD} = 5.0\text{V}$	—	8	12	
Supply current during power down	I_{DDS1}	$T_a \leq 40^\circ\text{C}$	—	0.5	2.0	μA
	I_{DDS2}	$T_a \leq 85^\circ\text{C}$	—	0.5	8.0	

Analog Characteristics

$V_{DD} = SPV_{DD} = 2.3 \text{ to } 5.5 \text{ V}$, $GND = SPGND = 0 \text{ V}$, $T_a = -40 \text{ to } +85^\circ\text{C}$

Parameter	Symbol	Condition	Min.	Typ.	Max.	Unit
AOUT output load resistance	R_{LAO}	During 1/2 DV_{DD} output	10	—	—	$k\Omega$
AOUT output voltage range	V_{AOUT}	No output load	$1/6 \times V_{DD}$	—	$5/6 \times V_{DD}$	V
SG output voltage	V_{SG}	—	$0.95 \times V_{DD}/2$	$V_{DD}/2$	$1.05 \times V_{DD}/2$	V
SG output resistance	R_{SG}	—	57	96	135	$k\Omega$
SPM, SPP output load resistance	R_{LSP}	—	8	—	—	Ω
Speaker amplifier output power	P_{SPO}	$SPV_{DD}=5.0\text{V}$, $f=1\text{kHz}$, $R_{SPO}=8\Omega$, $THD \geq 10\%$	—	1	—	W
Output offset voltage between SPM and SPP with no signal present	V_{OF}	SPIN-SPM gain=0dB 8 Ω load	-50	—	50	mV

Event Control example

○ Event Control example 1 (Only one playback in Play once mode)

Operation: Only one event specified is executed after event activation.
Control method: Input the event number to be executed to the EVIN0-4 pins.

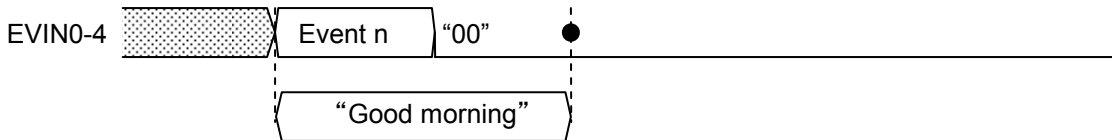

○ Event Control example 2 (Only one playback in Scheduled play mode)

Operation: Only one specification mode is executed
Control method: Input the event number to be executed to the EVIN0-4 pins. After event activation, input "00" to the EVIN0-4 pins before event execution is ended.

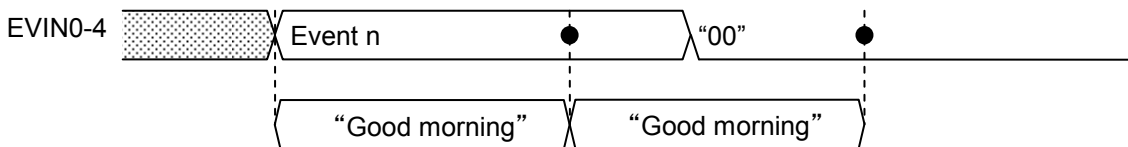

○ Event Control example 3 (Repetitive playback in Scheduled play mode)

Operation: While the EVIN0-4 pin states are held, the event execution is repeated.
In the case of the event execution stop, the event execution is terminated.
Control method: Input the event number to be executed to the EVIN0-4 pins. After event activation, hold the EVIN0-4 pin states. When desired to stop event execution, input all "0s" to the EVIN0-4 pins.

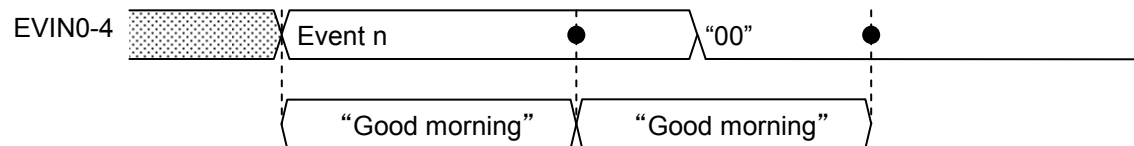

○ Event Control example 4 (Change in playback phrase in Scheduled play mode)

Operation: The event execution specified first is ended and newly specified event execution is started.
Control method: Input the event number to be executed to the EVIN0-4 pins. After event activation, input the event number to be executed next to the EVIN0-4 pins and hold the EVIN0-4 pin states until the current event execution is ended.

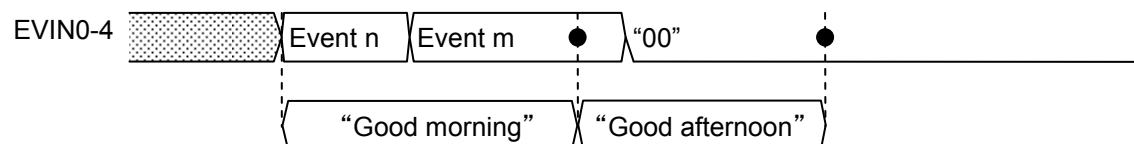

○ Event Control example 5 (Repetitive playback in Change immediately mode)

Operation: Event execution is performed until the EVIN0-4 pin states are changed. The event execution stops when the EVIN0-4 pin states are changed.

Control method: Input the event number to be executed to the EVIN0-4 pins. After event activation, hold the EVIN0-4 pin states while the event execution is to be performed. When desired to stop event execution, input all "0s" to the EVIN0-4 pins

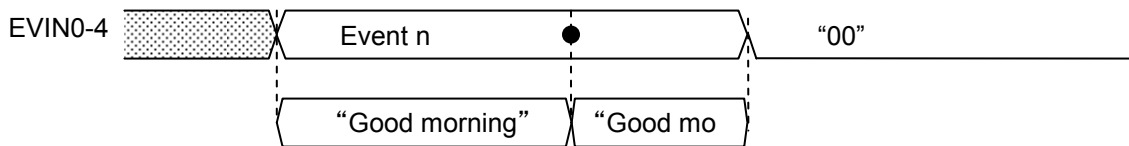

○ Event Control example 6 (Change in playback phrase in Change immediately mode)

Operation: The event execution specified first is ended and newly specified event execution is started.

Control method: Input the event number to be executed to the EVIN0-4 pins. After event activation, input the event number to be executed next to the EVIN0-4 pins

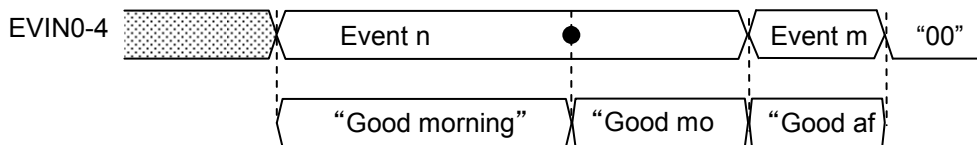

Configuration of Built-in ROM

The built-in ROM consists of the initialization, event management, and speech data areas.

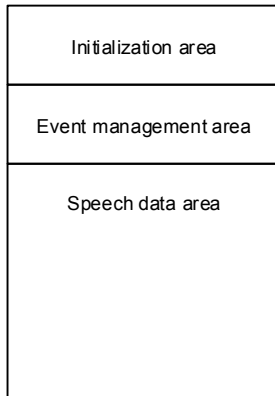

Built-in ROM configuration

Notes: Since the data which exceeds 64 K bytes in one phrase cannot be played, please divide the voice phrase to be set to each below 64 K bytes, and join those data by the edit phrase function.

EXAMPLE OF APPLICATION CIRCUIT

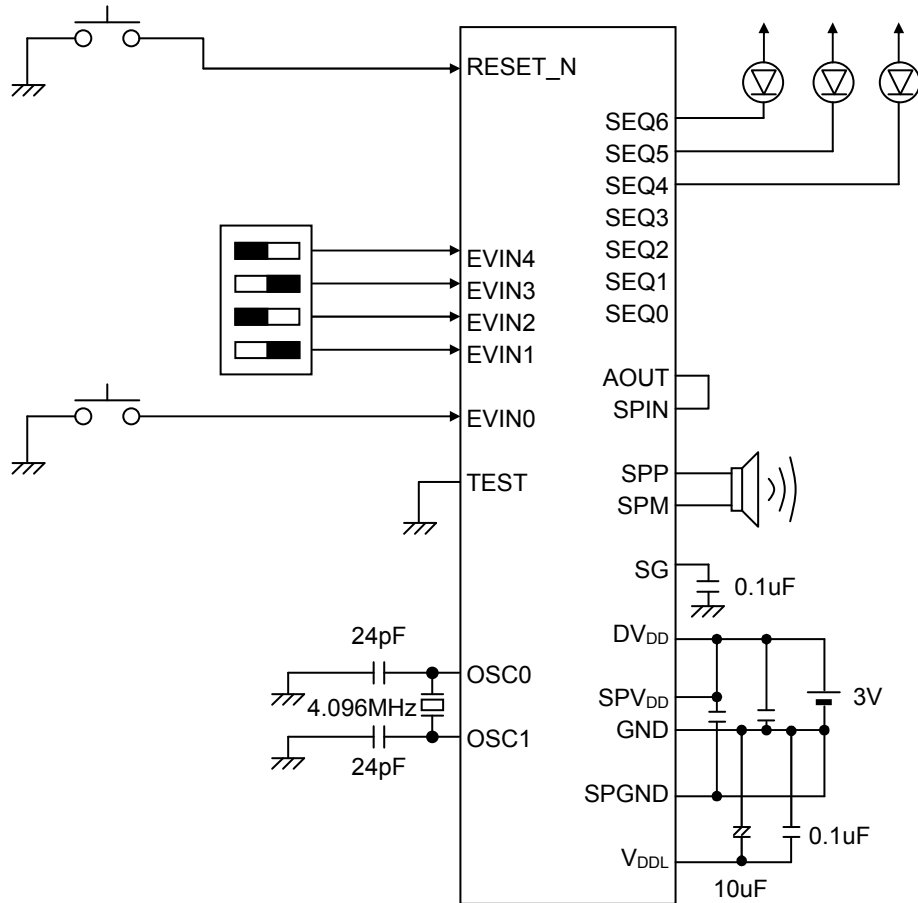

PACKAGE DIMENSIONS

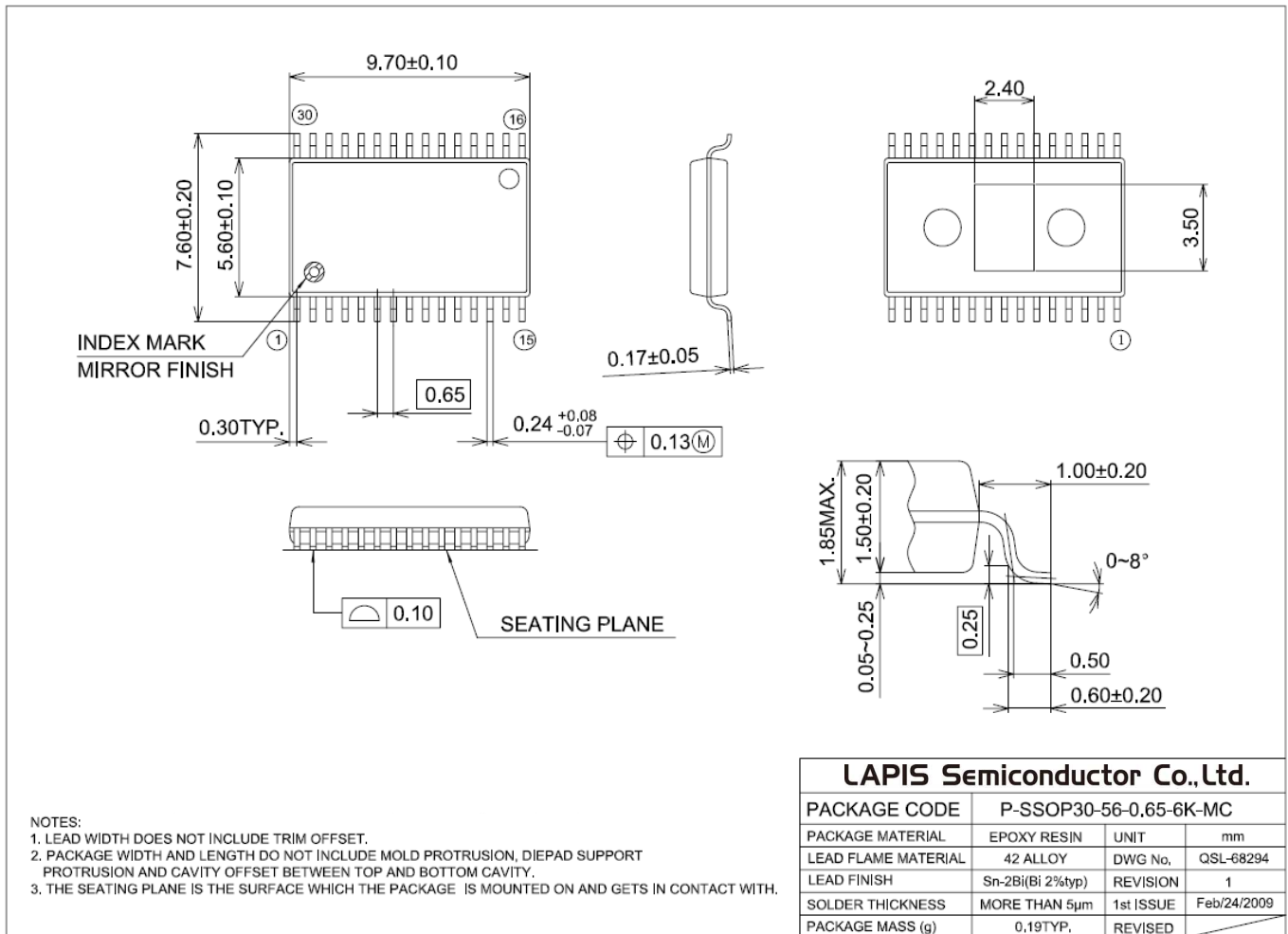

Notes for Mounting the Surface Mount Type Package

The surface mount type packages are very susceptible to heat in reflow mounting and humidity absorbed in storage. Therefore, before you perform reflow mounting, contact ROHM's responsible sales person for the product name, package name, pin number, package code and desired mounting conditions (reflow method, temperature and times).

NOTICE

No copying or reproduction of this document, in part or in whole, is permitted without the consent of LAPIS Semiconductor Co., Ltd.

The content specified herein is subject to change for improvement without notice.

The content specified herein is for the purpose of introducing LAPIS Semiconductor's products (hereinafter "Products"). If you wish to use any such Product, please be sure to refer to the specifications, which can be obtained from LAPIS Semiconductor upon request.

Examples of application circuits, circuit constants and any other information contained herein illustrate the standard usage and operations of the Products. The peripheral conditions must be taken into account when designing circuits for mass production.

Great care was taken in ensuring the accuracy of the information specified in this document. However, should you incur any damage arising from any inaccuracy or misprint of such information, LAPIS Semiconductor shall bear no responsibility for such damage.

The technical information specified herein is intended only to show the typical functions of and examples of application circuits for the Products. LAPIS Semiconductor does not grant you, explicitly or implicitly, any license to use or exercise intellectual property or other rights held by LAPIS Semiconductor and other parties. LAPIS Semiconductor shall bear no responsibility whatsoever for any dispute arising from the use of such technical information.

The Products specified in this document are intended to be used with general-use electronic equipment or devices (such as audio visual equipment, office-automation equipment, communication devices, electronic appliances and amusement devices).

The Products specified in this document are not designed to be radiation tolerant.

While LAPIS Semiconductor always makes efforts to enhance the quality and reliability of its Products, a Product may fail or malfunction for a variety of reasons.

Please be sure to implement in your equipment using the Products safety measures to guard against the possibility of physical injury, fire or any other damage caused in the event of the failure of any Product, such as derating, redundancy, fire control and fail-safe designs. LAPIS Semiconductor shall bear no responsibility whatsoever for your use of any Product outside of the prescribed scope or not in accordance with the instruction manual.

The Products are not designed or manufactured to be used with any equipment, device or system which requires an extremely high level of reliability the failure or malfunction of which may result in a direct threat to human life or create a risk of human injury (such as a medical instrument, transportation equipment, aerospace machinery, nuclear-reactor controller, fuel-controller or other safety device). LAPIS Semiconductor shall bear no responsibility in any way for use of any of the Products for the above special purposes. If a Product is intended to be used for any such special purpose, please contact a ROHM sales representative before purchasing.

If you intend to export or ship overseas any Product or technology specified herein that may be controlled under the Foreign Exchange and the Foreign Trade Law, you will be required to obtain a license or permit under the Law.

Copyright 2008 - 2011 LAPIS Semiconductor Co., Ltd.