

# ML9208A-xx

## 5 × 7 Dot Character × 16-Digit Display Controller/Driver with Character RAM

### GENERAL DESCRIPTION

The ML9208A-xx is a dot matrix vacuum fluorescent display tube controller driver IC which displays characters, numerics and symbols.

Dot matrix vacuum fluorescent display tube drive signals are generated by serial data sent from a micro-controller. A display system is easily realized by internal ROM and RAM for character display.

### FEATURES

- Logic power supply and vacuum fluorescent display tube drive power supply ( $V_{DD}$ ) : 3.3 V  $\pm$  0.3V or 5.0 V  $\pm$  0.5V
- Fluorescent display tube drive power supply ( $V_{FL}$ ) :  $V_{DD} - 20$  V to  $V_{DD} - 42$  V
- VFD driver output current  
(VFD driver output can be connected directly to the fluorescent display tube. No pull-down resistor is required.)
  - Segment driver (SEG1 to SEG35) : -6 mA ( $V_{FL} = V_{DD} - 42$  V)
  - Segment driver (AD1 and AD2) : -15 mA ( $V_{FL} = V_{DD} - 42$  V)
  - Grid driver (COM1 to COM16) : -30 mA ( $V_{FL} = V_{DD} - 42$  V)
- General output port output current
  - Output driver (P1 and P2) :  $\pm 1$  mA ( $V_{DD} = 3.3$  V  $\pm$  0.3V)  
:  $\pm 2$  mA ( $V_{DD} = 5.0$  V  $\pm$  0.5V)
- Content of display
  - CGROM 5 × 7 dots : 248 types (character data)
  - CGRAM 5 × 7 dots : 8 types (character data)
  - ADRAM 16 (display digit) × 2 bits (symbol data)
  - DCRAM 16 (display digit) × 8 bits (register for character data display)
  - General output port 2 bits (static operation)
- Display control function
  - Display digit : 9 to 16 digits
  - Display duty (contrast adjustment) : 16 stages
  - All lights ON/OFFs
- 3 interfaces with microcontroller :  $\overline{DA}$ ,  $\overline{CS}$ ,  $\overline{CP}$  (4 interfaces when  $\overline{RESET}$  is added)
- 1-byte instruction execution (excluding data write to RAM)
- Built-in oscillation circuit (external R and C)
- Package options:
  - 64-pin plastic QFP (QFP64-P-1414-0.80-BK) (ML9208A-xxGA)
  - 64-pin plastic SSOP (SSOP64-P-525-0.80-K) (ML9208A-xxMB)
  - 64-pin plastic TQFP (TQFP64-P-1010-0.50-K) (ML9208A-xxTB)

**BLOCK DIAGRAM**

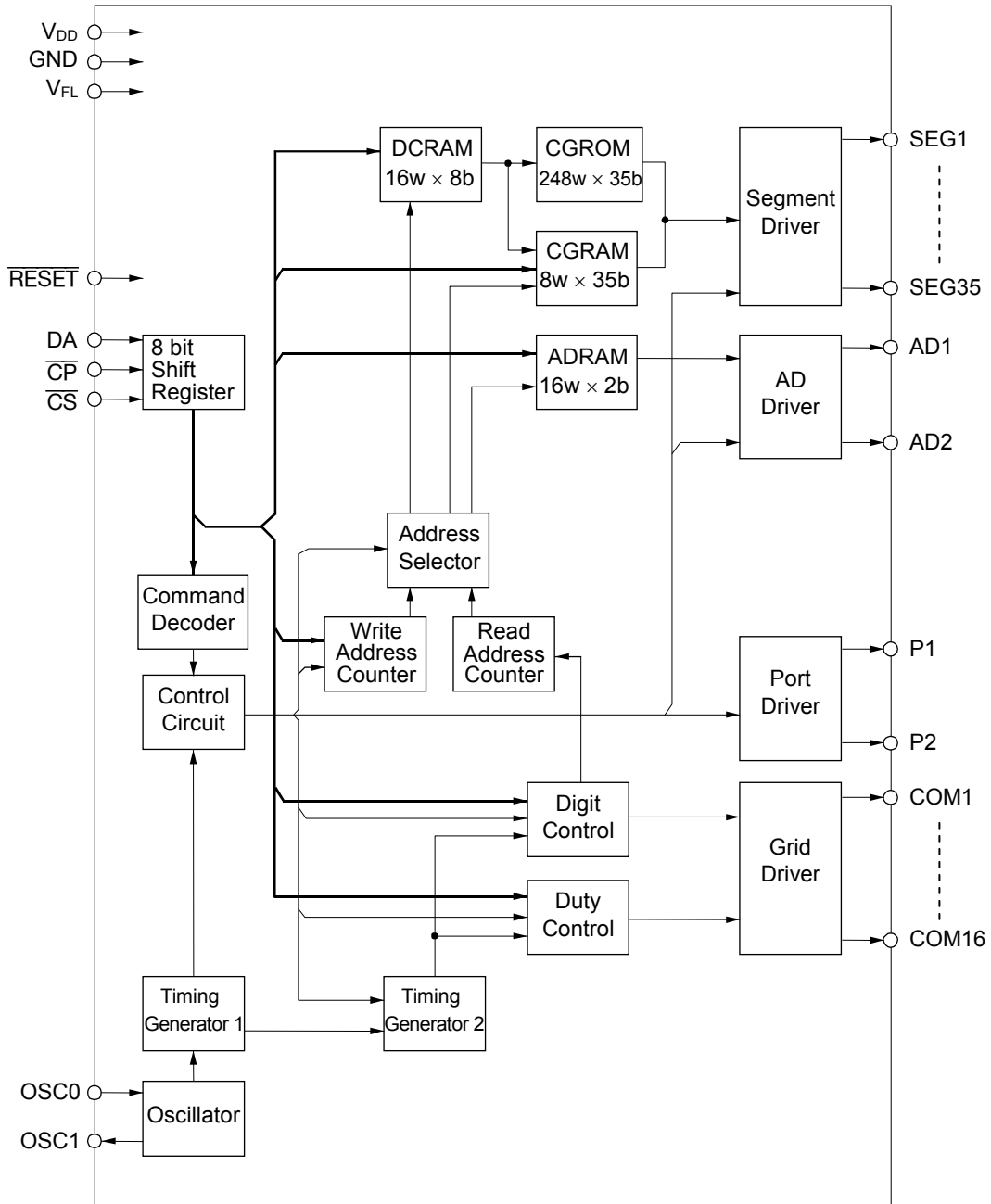

**PIN CONFIGURATION (TOP VIEW)**

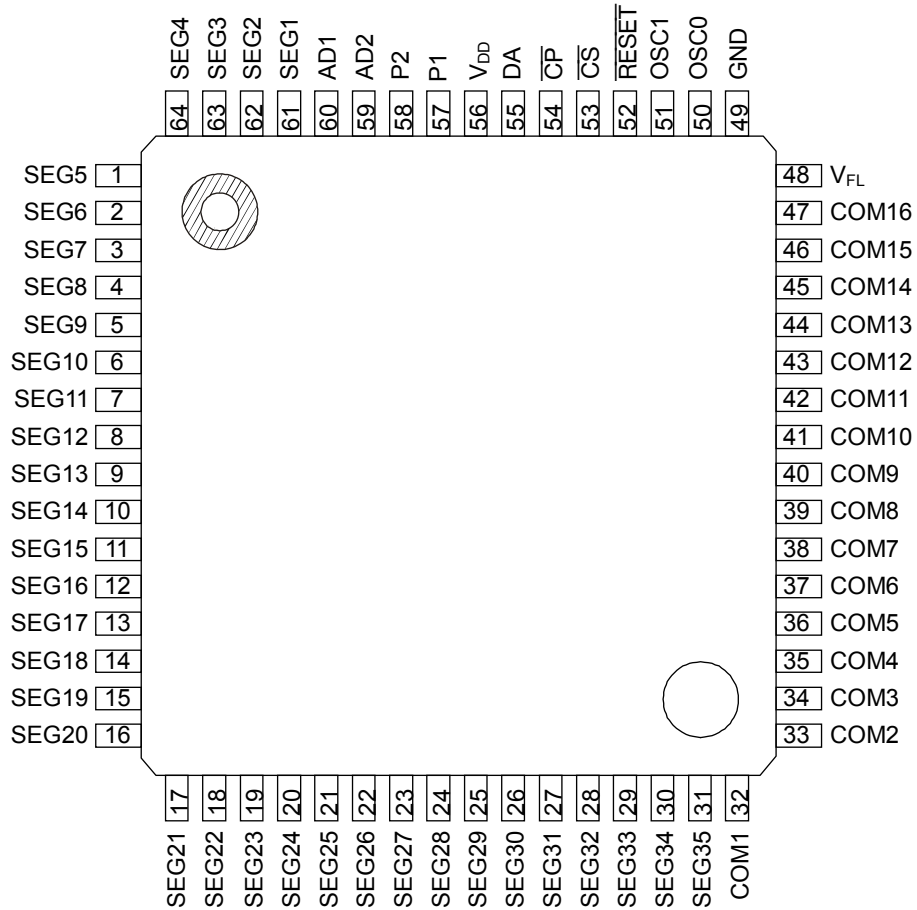

**64-Pin Plastic QFP / TQFP**

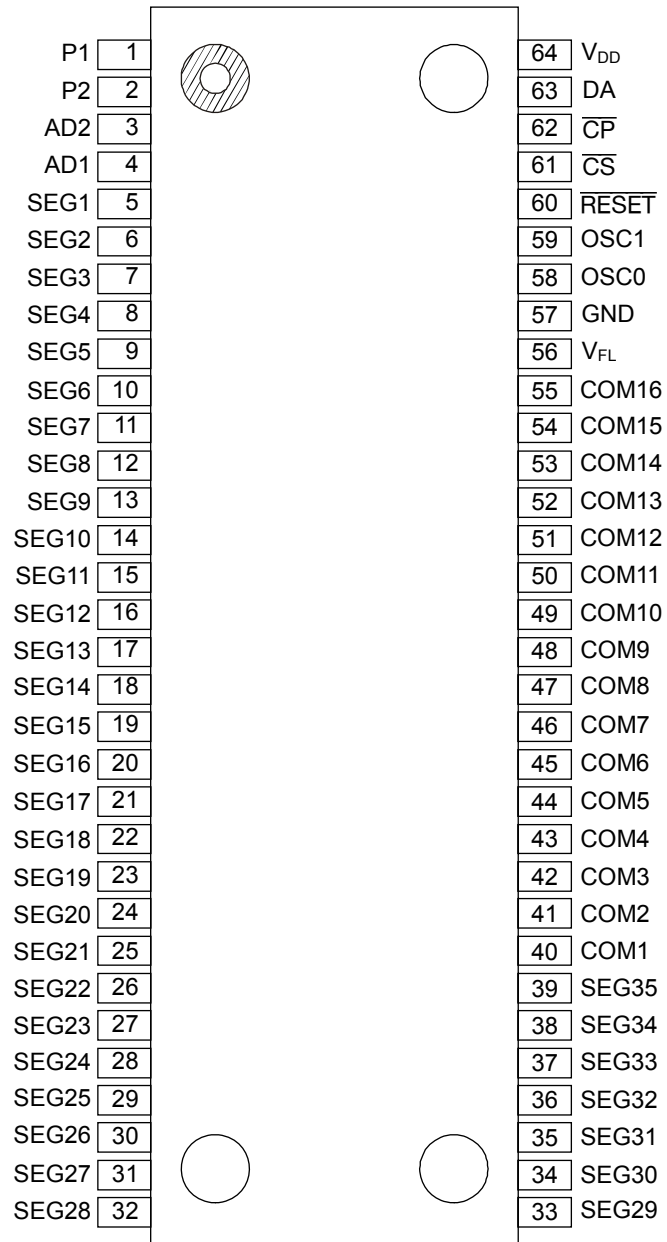

64-Pin Plastic SSOP

## PIN DESCRIPTION

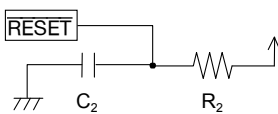
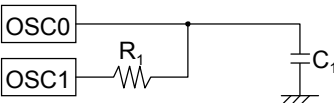
Pin		Symbol	Type	Connects to	Description
QFP / TQFP	SSOP				
1 to 31, 61 to 64	5 to 39	SEG1 to 35	O	Fluorescent tube anode electrode	Fluorescent display tube anode electrode drive output. Directly connected to fluorescent display tube and a pull-down resistor is not necessary. $I_{OH} > -6$ mA
32 to 47	40 to 55	COM1 to 16	O	Fluorescent tube grid electrode	Fluorescent display tube grid electrode drive output. Directly connected to fluorescent display tube and a pull-down resistor is not necessary. $I_{OH} > -30$ mA
59, 60	3, 4	AD1, AD2	O	Fluorescent tube anode electrode	Fluorescent display tube anode electrode drive output. Directly connected to fluorescent display tube and a pull-down resistor is not necessary. $I_{OH} > -15$ mA
57, 58	1, 2	P1, P2	O	LED drive control pins	General port output. Output of these pins in static operation, so these pins can drive the LED.
56	64	$V_{DD}$	—	Power supply	$V_{DD}$ -GND are power supplies for internal logic. $V_{DD}$ - $V_{FL}$ are power supplies for driving fluorescent tubes. Apply $V_{FL}$ after $V_{DD}$ is applied.
49	57	GND			
48	56	$V_{FL}$			
55	63	DA	I	Microcontroller	Serial data input (positive logic). Input from LSB.
54	62	$\overline{CP}$	I	Microcontroller	Shift clock input. Serial data is shifted on the rising edge of $\overline{CP}$ when $\overline{CS}$ pin is "L" level.
53	61	$\overline{CS}$	I	Microcontroller	Chip select input. Serial data transfer is enabled when $\overline{CS}$ pin is "L" level.
52	60	$\overline{RESET}$	I	Microcontroller or $C_2, R_2$	Reset input. "Low" initializes all the functions. Initial status is as follows. <ul style="list-style-type: none"> <li>• Address of each RAM .... address "00"H</li> <li>• Data of each RAM ..... Content is undefined</li> <li>• Display digit ..... 16 digits</li> <li>• Contrast adjustment ..... 0/16</li> <li>• All lights ON or OFF ..... OFF mode</li> <li>• All outputs ..... "Low" level</li> </ul>  <p>(Circuit when R and C are connected externally) See Application Circuit.</p>
50	58	OSC0	I	$C_1, R_1$	External RC pin for RC oscillation. Connect R and C externally. The RC time constant depends on the $V_{DD}$ voltage used. Set the target oscillation frequency to 2 MHz.
51	59	OSC1	O		 <p>(RC oscillation circuit) See Application Circuit.</p>

**ABSOLUTE MAXIMUM RATINGS**

Parameter	Symbol	Condition	Rating	Unit	
Supply Voltage (1)	$V_{DD}$	—	-0.3 to 6.5	V	
Supply Voltage (2)	$V_{FL}$	—	-45 to $V_{DD} + 0.3$	V	
Input Voltage	$V_{IN}$	—	-0.3 to $V_{DD} + 0.3$	V	
Power Dissipation	$P_D$	$T_a \geq 25^\circ\text{C}$	QFP	541	mW
			SSOP	590	
			TQFP	541	
Storage Temperature	$T_{STG}$	—	-55 to 150	$^\circ\text{C}$	
Output Current	$I_{O1}$	COM1 to 16	-40 to 0.0	mA	
	$I_{O2}$	AD1, AD2	-20 to 0.0	mA	
	$I_{O3}$	SEG1 to 35	-10 to 0.0	mA	
	$I_{O4}$	P1, P2	-4.0 to 4.0	mA	

**RECOMMENDED OPERATING CONDITIONS-1**

When the power supply voltage is 5 V (typ.)

Parameter	Symbol	Condition	Min.	Typ.	Max.	Unit
Supply Voltage (1)	$V_{DD}$	—	4.5	5.0	5.5	V
Supply Voltage (2)	$V_{FL}$	—	-36.5	—	-20	V
High Level Input Voltage	$V_{IH}$	All input pins excluding OSC0 pin	$0.7 V_{DD}$	—	—	V
Low Level Input Voltage	$V_{IL}$	All input pins excluding OSC0 pin	—	—	$0.3 V_{DD}$	V
$\overline{CP}$ Frequency	$f_C$	—	—	—	2.0	MHz
Oscillation Frequency	$f_{OSC}$	$R_1 = 3.3 \text{ k}\Omega$ , $C_1 = 39 \text{ pF}$	1.5	2.0	2.5	MHz
Frame Frequency	$f_{FR}$	DIGIT = 1 to 16, $R_1 = 3.3 \text{ k}\Omega$ , $C_1 = 39 \text{ pF}$	183	244	305	Hz
Operating Temperature	$T_{op}$	—	-40	—	85	$^\circ\text{C}$

**RECOMMENDED OPERATING CONDITIONS-2**

When the power supply voltage is 3.3 V (typ.)

Parameter	Symbol	Condition	Min.	Typ.	Max.	Unit
Supply Voltage (1)	V <sub>DD</sub>	—	3.0	3.3	3.6	V
Supply Voltage (2)	V <sub>FL</sub>	—	-38.4	—	-20	V
High Level Input Voltage	V <sub>IH</sub>	All input pins excluding OSC0 pin	0.8 V <sub>DD</sub>	—	—	V
Low Level Input Voltage	V <sub>IL</sub>	All input pins excluding OSC0 pin	—	—	0.2 V <sub>DD</sub>	V
CP Frequency	f <sub>C</sub>	—	—	—	2.0	MHz
Oscillation Frequency	f <sub>OSC</sub>	R <sub>1</sub> = 3.3 kΩ, C <sub>1</sub> = 39 pF	1.5	2.0	2.5	MHz
Frame Frequency	f <sub>FR</sub>	DIGIT = 1 to 16, R <sub>1</sub> = 3.3 kΩ, C <sub>1</sub> = 39 pF	183	244	305	Hz
Operating Temperature	T <sub>op</sub>	—	-40	—	85	°C

**ELECTRICAL CHARACTERISTICS****DC Characteristics-1**

(V<sub>DD</sub> = 5.0 V ± 0.5V, V<sub>FL</sub> = V<sub>DD</sub> - 42 V, Ta = -40 to +85°C, unless otherwise specified)

Parameter	Symbol	Applied pin	Condition	Min.	Max.	Unit	
High Level Input Voltage	V <sub>IH</sub>	CS, CP, DA, RESET	—	0.7 V <sub>DD</sub>	—	V	
Low Level Input Voltage	V <sub>IL</sub>	CS, CP, DA, RESET	—	—	0.3 V <sub>DD</sub>	V	
High Level Input Current	I <sub>IH</sub>	CS, CP, DA, RESET	V <sub>IH</sub> = V <sub>DD</sub>	-1.0	1.0	μA	
Low Level Input Current	I <sub>IL</sub>	CS, CP, DA, RESET	V <sub>IL</sub> = 0.0 V	-1.0	1.0	μA	
High Level Output Voltage	V <sub>OH1</sub>	COM1 to 16	I <sub>OH1</sub> = -30 mA	V <sub>DD</sub> - 1.5	—	V	
	V <sub>OH2</sub>	AD1, AD2	I <sub>OH2</sub> = -15 mA	V <sub>DD</sub> - 1.5	—	V	
	V <sub>OH3</sub>	SEG1 to 35	I <sub>OH3</sub> = -6 mA	V <sub>DD</sub> - 1.5	—	V	
	V <sub>OH4</sub>	P1, P2	I <sub>OH4</sub> = -2 mA	V <sub>DD</sub> - 1.0	—	V	
Low Level Output Voltage	V <sub>OL1</sub>	COM1 to 16 AD1, AD2 SEG1 to 35	—	—	V <sub>FL</sub> + 1.0	V	
	V <sub>OL2</sub>	P1, P2	I <sub>OL1</sub> = 2 mA	—	1.0	V	
Current Consumption	I <sub>DD1</sub>	V <sub>DD</sub>	f <sub>OSC</sub> = 2 MHz, no load	Duty = 15/16 Digit = 1 to 16 All output lights ON	—	4	mA
	I <sub>DD2</sub>			Duty = 8/16 Digit = 1 to 9 All output lights OFF	—	3	mA

**DC Characteristics-2** $(V_{DD} = 3.3 \text{ V} \pm 0.3\text{V}, V_{FL} = V_{DD} - 42 \text{ V}, T_a = -40 \text{ to } +85^\circ\text{C}, \text{ unless otherwise specified})$ 

Parameter	Symbol	Applied pin	Condition	Min.	Max.	Unit	
High Level Input Voltage	$V_{IH}$	$\overline{CS}, \overline{CP},$ DA, $\overline{RESET}$	—	$0.8 V_{DD}$	—	V	
Low Level Input Voltage	$V_{IL}$	$\overline{CS}, \overline{CP},$ DA, $\overline{RESET}$	—	—	$0.2 V_{DD}$	V	
High Level Input Current	$I_{IH}$	$\overline{CS}, \overline{CP},$ DA, $\overline{RESET}$	$V_{IH} = V_{DD}$	-1.0	1.0	$\mu\text{A}$	
Low Level Input Current	$I_{IL}$	$\overline{CS}, \overline{CP},$ DA, $\overline{RESET}$	$V_{IL} = 0.0 \text{ V}$	-1.0	1.0	$\mu\text{A}$	
High Level Output Voltage	$V_{OH1}$	COM1 to 16	$I_{OH1} = -30 \text{ mA}$	$V_{DD} - 1.5$	—	V	
	$V_{OH2}$	AD1, AD2	$I_{OH2} = -15 \text{ mA}$	$V_{DD} - 1.5$	—	V	
	$V_{OH3}$	SEG1 to 35	$I_{OH3} = -6 \text{ mA}$	$V_{DD} - 1.5$	—	V	
	$V_{OH4}$	P1, P2	$I_{OH4} = -1 \text{ mA}$	$V_{DD} - 1.0$	—	V	
Low Level Output Voltage	$V_{OL1}$	COM1 to 16 AD1, AD2 SEG1 to 35	—	—	$V_{FL} + 1.0$	V	
	$V_{OL2}$	P1, P2	$I_{OL1} = 1 \text{ mA}$	—	1.0	V	
Current Consumption	$I_{DD1}$	$V_{DD}$	$F_{OSC} =$ 2 MHz, no load	Duty = 15/16 Digit = 1 to 16 All output lights ON	—	3	mA
	$I_{DD2}$			Duty = 8/16 Digit = 1 to 9 All output lights OFF	—	2	mA

## AC Characteristics-1

(V<sub>DD</sub> = 5.0 V ± 0.5V, V<sub>FL</sub> = V<sub>DD</sub> - 42 V, Ta = -40 to +85°C, unless otherwise specified)

Parameter	Symbol	Condition	Min.	Max.	Unit	
CP Frequency	f <sub>C</sub>	—	—	2.0	MHz	
CP Pulse Width	t <sub>CW</sub>	—	250	—	ns	
DA Setup Time	t <sub>DS</sub>	—	250	—	ns	
DA Hold Time	t <sub>DH</sub>	—	250	—	ns	
CS Setup Time	t <sub>CSS</sub>	—	250	—	ns	
CS Hold Time	t <sub>CSH</sub>	R <sub>1</sub> = 3.3 kΩ, C <sub>1</sub> = 39 pF	16	—	μs	
CS Wait Time	t <sub>CSW</sub>	—	250	—	ns	
Data Processing Time	t <sub>DOFF</sub>	R <sub>1</sub> = 3.3 kΩ, C <sub>1</sub> = 39 pF	8	—	μs	
RESET Pulse Width	t <sub>WRES</sub>	When RESET signal is input from microcontroller etc. externally	250	—	ns	
RESET Time	t <sub>RSON</sub>	When RESET signal is input from microcontroller etc. externally	250	—	ns	
		R <sub>2</sub> = 1.0 kΩ, C <sub>2</sub> = 0.1 μF	—	200	μs	
DA Wait Time	t <sub>RSOFF</sub>	—	250	—	ns	
All Output Slew Rate	t <sub>R</sub>	C <sub>1</sub> = 100 pF	t <sub>R</sub> = 20 to 80%	—	2.0	μs
	t <sub>F</sub>		t <sub>F</sub> = 80 to 20%	—	2.0	μs
V <sub>DD</sub> Rise Time	t <sub>PRZ</sub>	When mounted in the unit	—	100	μs	
V <sub>DD</sub> Off Time	t <sub>POF</sub>	When mounted in the unit, V <sub>DD</sub> = 0.0 V	5.0	—	ms	

## AC Characteristics-2

(V<sub>DD</sub> = 3.3 V ± 0.3V, V<sub>FL</sub> = V<sub>DD</sub> - 42 V, Ta = -40 to +85°C, unless otherwise specified)

Parameter	Symbol	Condition	Min.	Max.	Unit	
CP Frequency	f <sub>C</sub>	—	—	2.0	MHz	
CP Pulse Width	t <sub>CW</sub>	—	250	—	ns	
DA Setup Time	t <sub>DS</sub>	—	250	—	ns	
DA Hold Time	t <sub>DH</sub>	—	250	—	ns	
CS Setup Time	t <sub>CSS</sub>	—	250	—	ns	
CS Hold Time	t <sub>CSH</sub>	R <sub>1</sub> = 3.3 kΩ, C <sub>1</sub> = 39 pF	16	—	μs	
CS Wait Time	t <sub>CSW</sub>	—	250	—	ns	
Data Processing Time	t <sub>DOFF</sub>	R <sub>1</sub> = 3.3 kΩ, C <sub>1</sub> = 39 pF	8	—	μs	
RESET Pulse Width	t <sub>WRES</sub>	When RESET signal is input from microcontroller etc. externally	250	—	ns	
RESET Time	t <sub>RSON</sub>	When RESET signal is input from microcontroller etc. externally	250	—	ns	
		R <sub>2</sub> = 1.0 kΩ, C <sub>2</sub> = 0.1 μF	—	200	μs	
DA Wait Time	t <sub>RSOFF</sub>	—	250	—	ns	
All Output Slew Rate	t <sub>R</sub>	C <sub>1</sub> = 100 pF	t <sub>R</sub> = 20 to 80%	—	2.0	μs
	t <sub>F</sub>		t <sub>F</sub> = 80 to 20%	—	2.0	μs
V <sub>DD</sub> Rise Time	t <sub>PRZ</sub>	When mounted in the unit	—	100	μs	
V <sub>DD</sub> Off Time	t <sub>POF</sub>	When mounted in the unit, V <sub>DD</sub> = 0.0 V	5.0	—	ms	

**TIMING DIAGRAM**

Symbol	$V_{DD} = 3.3\text{ V} \pm 0.3\text{V}$	$V_{DD} = 5.0\text{ V} \pm 0.5\text{V}$
$V_{IH}$	$0.8 V_{DD}$	$0.7 V_{DD}$
$V_{IL}$	$0.2 V_{DD}$	$0.3 V_{DD}$

**• Data Timing**

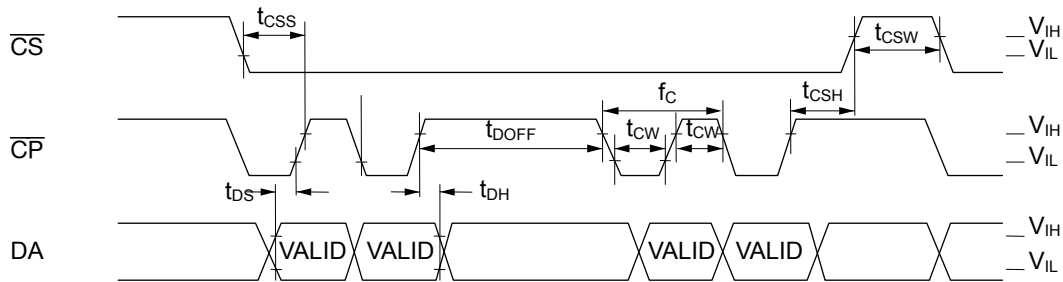

**• Reset Timing**

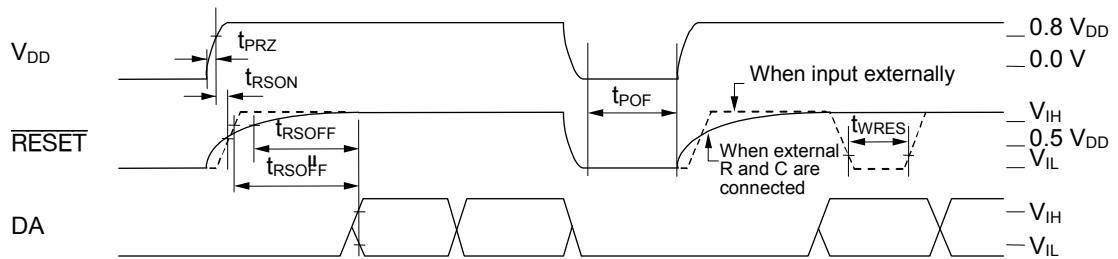

**• Output Timing**



• Digit Output Timing (for 16-digit display, at a duty of 15/16)

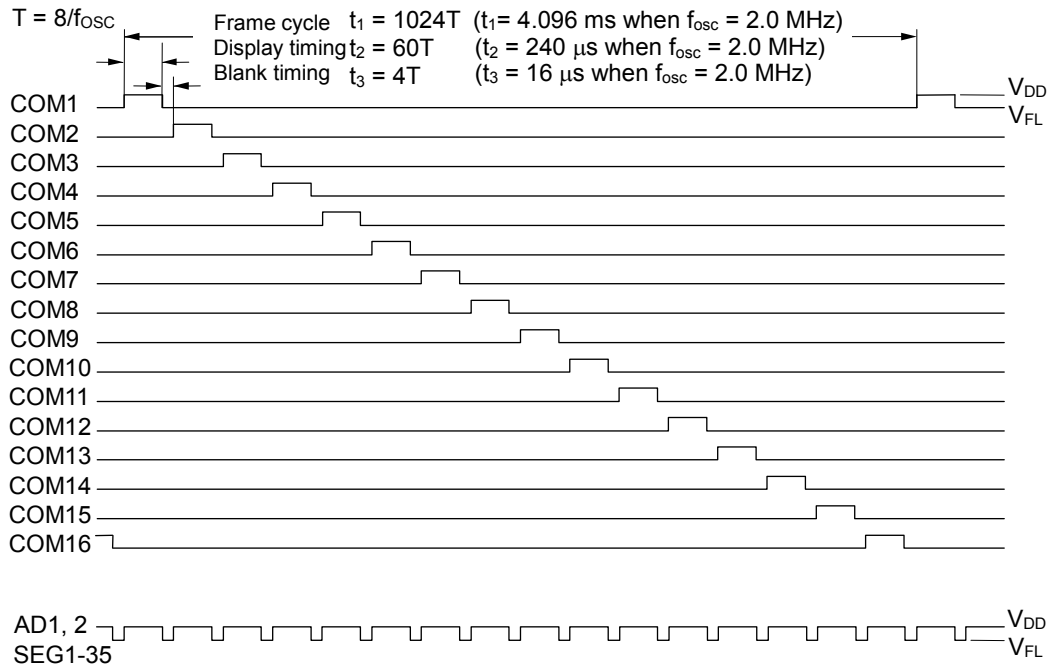

## FUNCTIONAL DESCRIPTION

### Commands List

	Command	1st byte								2nd byte								
		LSB	1st byte							MSB	LSB	2nd byte						
		B0	B1	B2	B3	B4	B5	B6	B7	B0	B1	B2	B3	B4	B5	B6	B7	
1	DCRAM data write	X0	X1	X2	X3	1	0	0	0	C0	C1	C2	C3	C4	C5	C6	C7	
2	CGRAM data write	X0	X1	X2	*	0	1	0	0	C0	C5	C10	C15	C20	C25	C30	*	2nd byte
										C1	C6	C11	C16	C21	C26	C31	*	3rd byte
										C2	C7	C12	C17	C22	C27	C32	*	4th byte
										C3	C8	C13	C18	C23	C28	C33	*	5th byte
										C4	C9	C14	C19	C24	C29	C34	*	6th byte
3	ADRAM data write	X0	X1	X2	X3	1	1	0	0	C0	C1	*	*	*	*	*	*	
4	General output port set	P1	P2	*	*	0	0	1	0	*: Don't care								
5	Display duty set	D0	D1	D2	D3	1	0	1	0	Xn: Address specification for each RAM								
6	Number of digits set	K0	K1	K2	*	0	1	1	0	Cn: Character code specification for each RAM								
7	All lights ON/OFF	L	H	*	*	1	1	1	0	Pn: General output port status specification								
	Test mode									Dn: Display duty specification								
										Kn: Number of digits specification								
										H: All lights ON instruction								
										L: All lights OFF instruction								

When data is written to RAM (DCRAM, CGRAM, ADRAM) continuously, addresses are internally incremented automatically.

Therefore it is not necessary to specify the 1st byte to write RAM data for the 2nd and later bytes.

Note: The test mode is used for inspection before shipment. It is not a user function.

**Positional Relationship Between SEGn and ADn (one digit)**

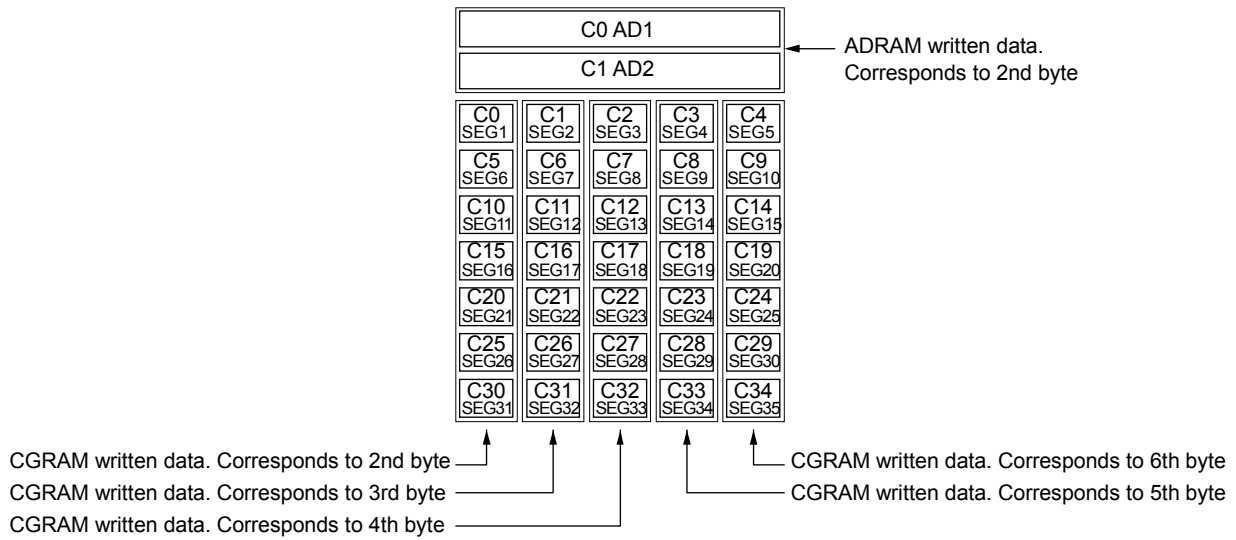

## Data Transfer Method and Command Write Method

Display control command and data are written by an 8-bit serial transfer. Write timing is shown in the figure below.

Setting the  $\overline{CS}$  pin to “Low” level enables a data transfer.

Data is 8 bits and is sequentially input into the DA pin from LSB (LSB first).

As shown in the figure below, data is read by the shift register at the rising edge of the shift clock, which is input into the  $\overline{CP}$  pin. If 8-bit data is input, internal load signals are automatically generated and data is written to each register and RAM.

Therefore it is not necessary to input load signals from the outside.

Setting the  $\overline{CS}$  pin to “High” disables data transfer. Data input from the point when the  $\overline{CS}$  pin changes from “High” to “Low” is recognized in 8-bit units.

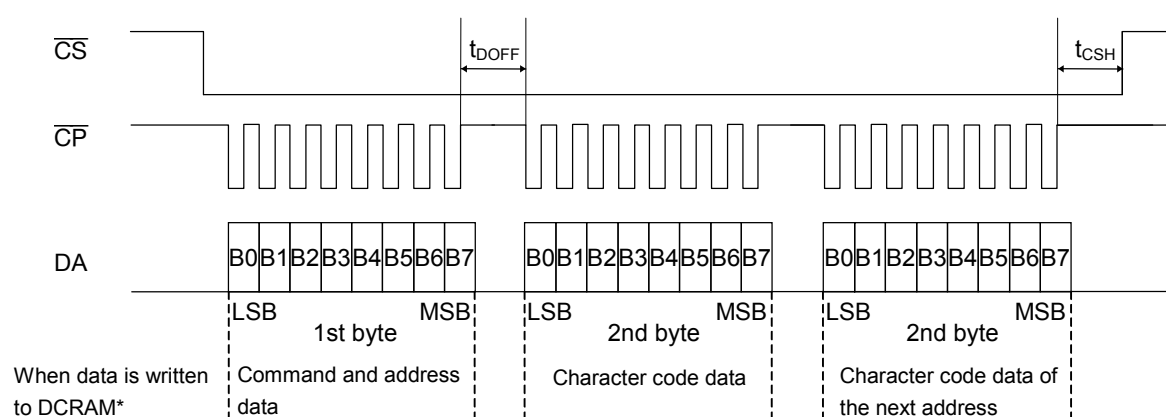

\* When data is written to RAM (DCRAM, ADRAM, CGRAM) continuously, addresses are internally incremented automatically.

Therefore it is not necessary to specify the 1st byte to write RAM data for the 2nd and later bytes.

## Reset Function

Reset is executed when the  $\overline{RESET}$  pin is set to “L”, (when turning power on, for example) and initializes all functions.

Initial status is as follows.

- Address of each RAM ..... address “00”H
- Data of each RAM ..... All contents are undefined
- General output port ..... All general output ports go “Low”
- Display digit ..... 16 digits
- Contrast adjustment ..... 0/16
- All display lights ON or OFF .... OFF mode
- Segment output ..... All segment outputs go “Low”
- AD output ..... All AD outputs go “Low”

Please set again according to “Setting Flowchart” after reset.

## Description of Commands and Functions

1. DCRAM data write  
(Specifies the address of DCRAM and writes the character code of CGROM and CGRAM.)

DCRAM (Data Control RAM) has a 4-bit address to store character code of CGROM and CGRAM. The character code specified by DCRAM is converted to a  $5 \times 7$  dot matrix character pattern via CGROM or CGRAM.

(The DCRAM can store 16 characters.)

[Command format]

	LSB							MSB	
	B0	B1	B2	B3	B4	B5	B6	B7	
1st byte (1st)	X0	X1	X2	X3	1	0	0	0	: selects DCRAM data write mode and specifies DCRAM address (Ex: Specifies DCRAM address 0H)
	LSB							MSB	
	B0	B1	B2	B3	B4	B5	B6	B7	
2nd byte (2nd)	C0	C1	C2	C3	C4	C5	C6	C7	: specifies character code of CGROM and CGRAM (written into DCRAM address 0H)

To specify the character code of CGROM and CGRAM continuously to the next address, specify only character code as follows.

The addresses of DCRAM are automatically incremented. Specification of an address is unnecessary.

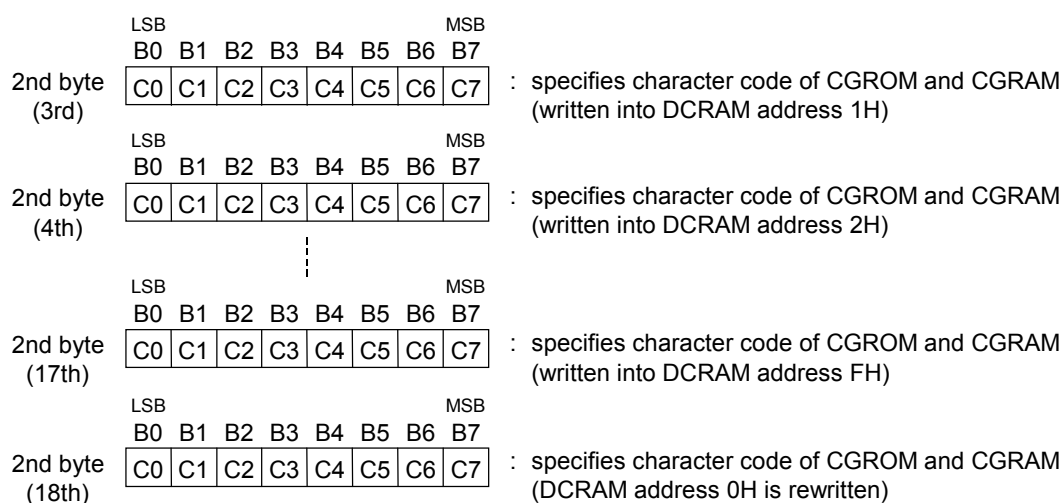

X0 (LSB) to X3 (MSB) : DCRAM addresses (4 bits: 16 characters)

C0 (LSB) to C7 (MSB) : Character code of CGROM and CGRAM (8 bits: 256 characters)

[COM positions and set DCRAM addresses]

HEX	X0	X1	X2	X3	COM position
0	0	0	0	0	COM1
1	1	0	0	0	COM2
2	0	1	0	0	COM3
3	1	1	0	0	COM4
4	0	0	1	0	COM5
5	1	0	1	0	COM6
6	0	1	1	0	COM7
7	1	1	1	0	COM8
8	0	0	0	1	COM9
9	1	0	0	1	COM10
A	0	1	0	1	COM11
B	1	1	0	1	COM12
C	0	0	1	1	COM13
D	1	0	1	1	COM14
E	0	1	1	1	COM15
F	1	1	1	1	COM16

2. CGRAM data write  
(Specifies the addresses of CGRAM and writes character pattern data.)

CGRAM (Character Generator RAM) has a 3-bit address to store  $5 \times 7$  dot matrix character patterns. A character pattern stored in CGRAM can be displayed by specifying the character code (address) by DGRAM.

The address of CGRAM is assigned to 00H to 07H. (All the other addresses are the CGROM addresses.)  
(The CGRAM can store 8 types of character patterns.)

[Command format]

	LSB							MSB	
	B0	B1	B2	B3	B4	B5	B6	B7	
1st byte (1st)	X0	X1	X2	*	0	1	0	0	: selects CGRAM data write mode and specifies CGRAM address. (Ex: specifies CGRAM address 00H)
	LSB							MSB	
	B0	B1	B2	B3	B4	B5	B6	B7	
2nd byte (2nd)	C0	C5	C10	C15	C20	C25	C30	*	: specifies 1st column data (rewritten into CGRAM address 00H)
	LSB							MSB	
	B0	B1	B2	B3	B4	B5	B6	B7	
3rd byte (3rd)	C1	C6	C11	C16	C21	C26	C31	*	: specifies 2nd column data (rewritten into CGRAM address 00H)
	LSB							MSB	
	B0	B1	B2	B3	B4	B5	B6	B7	
4th byte (4th)	C2	C7	C12	C17	C22	C27	C32	*	: specifies 3rd column data (rewritten into CGRAM address 00H)
	LSB							MSB	
	B0	B1	B2	B3	B4	B5	B6	B7	
5th byte (5th)	C3	C8	C13	C18	C23	C28	C33	*	: specifies 4th column data (rewritten into CGRAM address 00H)
	LSB							MSB	
	B0	B1	B2	B3	B4	B5	B6	B7	
6th byte (6th)	C4	C9	C14	C19	C24	C29	C34	*	: specifies 5th column data (rewritten into CGRAM address 00H)

To specify character pattern data continuously to the next address, specify only character pattern data as follows.

The addresses of CGRAM are automatically incremented. Specification of an address is therefore unnecessary.

The 2nd to 6th byte (character pattern data) are regarded as one data item, so 250ns is sufficient for  $t_{\text{DOFF}}$  time between bytes.

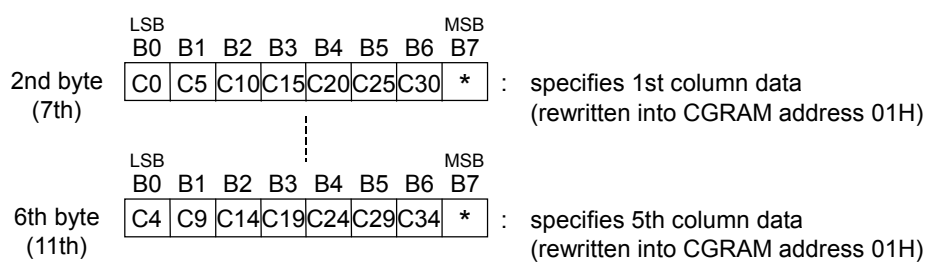

X0 (LSB) to X2 (MSB) : CGRAM addresses (3 bits: 8 characters)

C0 (LSB) to C34 (MSB) : Character pattern data (35 bits: 35 outputs per digit)

\* : Don't care

[CGROM addresses and set CGRAM addresses]

Refer to ROMCODE table

HEX	X0	X1	X2	CGROM address
00	0	0	0	RAM00(00000000B)
01	1	0	0	RAM01(00000001B)
02	0	1	0	RAM02(00000010B)
03	1	1	0	RAM03(00000011B)
04	0	0	1	RAM04(00000100B)
05	1	0	1	RAM05(00000101B)
06	0	1	1	RAM06(00000110B)
07	1	1	1	RAM07(00000111B)



### 3. ADRAM data write (specifies address of ADRAM and writes symbol data)

ADRAM (Additional Data RAM) has a 2-bit address to store symbol data.  
Symbol data specified by ADRAM is directly output without CGROM and CGRAM.  
(The ADRAM can store 2 types of symbol patterns for each digit.)  
The terminal to which the contents of ADRAM are output can be used as a cursor.

[Command format]

	LSB	B0	B1	B2	B3	B4	B5	B6	B7	MSB	
1st byte (1st)	X0	X1	X2	X3	1	1	0	0			: selects ADRAM data write mode and specifies ADRAM address (Ex: specifies ADRAM address 0H)
2nd byte (2nd)	C0	C1	*	*	*	*	*	*	*		: sets symbol data (written into ADRAM address 0H)

To specify symbol data continuously to the next address, specify only symbol data as follows.  
The address of ADRAM is automatically incremented. Specification of addresses is therefore unnecessary.

	LSB	B0	B1	B2	B3	B4	B5	B6	B7	MSB	
2nd byte (3rd)	C0	C1	*	*	*	*	*	*	*		: sets symbol data (written into ADRAM address 1H)
2nd byte (4th)	C0	C1	*	*	*	*	*	*	*		: sets symbol data (written into ADRAM address 2H)
2nd byte (17th)	C0	C1	*	*	*	*	*	*	*		: sets symbol data (written into ADRAM address FH)
2nd byte (18th)	C0	C1	*	*	*	*	*	*	*		: sets symbol data (ADRAM address 0H is rewritten.)

X0 (LSB) to X3 (MSB) : ADRAM addresses (4 bits: 16 characters)

C0 (LSB) to C1 (MSB) : Symbol data (2 bits: 2-symbol data per digit)

\*: Don't care

[COM positions and ADRAM addresses]

HEX	X0	X1	X2	X3	COM position
0	0	0	0	0	COM1
1	1	0	0	0	COM2
2	0	1	0	0	COM3
3	1	1	0	0	COM4
4	0	0	1	0	COM5
5	1	0	1	0	COM6
6	0	1	1	0	COM7
7	1	1	1	0	COM8
8	0	0	0	1	COM9
9	1	0	0	1	COM10
A	0	1	0	1	COM11
B	1	1	0	1	COM12
C	0	0	1	1	COM13
D	1	0	1	1	COM14
E	0	1	1	1	COM15
F	1	1	1	1	COM16

#### 4. General output port set (specifies the general output port status)

The general output port is an output for 2-bit static operation.

It is used to control other I/O devices and turn on LED. (static operation)

When at the "High" level, this output becomes the  $V_{DD}$  voltage, and when at the "Low" level, it becomes the ground potential. Therefore, the fluorescent display tube cannot be driven.

[Command format]

	LSB							MSB		
	B0	B1	B2	B3	B4	B5	B6	B7		
1st byte	P1	P2	*	*	0	0	1	0	: selects a general output port and specifies the output status	

P1, P2 : general output port

\* : don't care

[Set data and set state of general output port]

P1	P2	Display state of general output port
0	0	Sets P1 and P2 to low
1	0	Sets P1 to high and P2 to low
0	1	Sets P1 to low and P2 to high
1	1	Sets P1 and P2 to high

← (The state when power is applied or when  $\overline{\text{RESET}}$  is input.)

5. Display duty set  
(writes display duty value to duty cycle register)

Display duty adjusts contrast in 16 stages using 4-bit data.

When power is turned on or when the  $\overline{\text{RESET}}$  signal is input, the duty cycle register value is "0". Always execute this instruction before turning the display on, then set a desired duty value.

[Command format]

LSB
MSB  
B0 B1 B2 B3 B4 B5 B6 B7

1st byte 

D0	D1	D2	D3	1	0	1	0
----	----	----	----	---	---	---	---

 : selects display duty set mode and sets duty value

D0 (LSB) to D2 (MSB) : display duty data (4 bits: 16 stages)

\* : don't care

[Relation between setup data and controlled COM duty]

HEX	D0	D1	D2	D3	COM duty	HEX	D0	D1	D2	D3	COM duty
0	0	0	0	0	0/16	8	0	0	0	1	8/16
1	1	0	0	0	1/16	9	1	0	0	1	9/16
2	0	1	0	0	2/16	A	0	1	0	1	10/16
3	1	1	0	0	3/16	B	1	1	0	1	11/16
4	0	0	1	0	4/16	C	0	0	1	1	12/16
5	1	0	1	0	5/16	D	1	0	1	1	13/16
6	0	1	1	0	6/16	E	0	1	1	1	14/16
7	1	1	1	0	7/16	F	1	1	1	1	15/16

\* The state when power is turned on or when the  $\overline{\text{RESET}}$  signal is input.

6. Number of digits set  
(writes the number of display digits to the display digit register)

The number of digits set can display 9 to 16 digits using 3-bit data.

When power is turned on or when a  $\overline{\text{RESET}}$  signal is input, the number of digit register value is "0". Always execute this instruction to change the number of digits before turning the display on.

[Command format]

	LSB							MSB	
	B0	B1	B2	B3	B4	B5	B6	B7	
1st byte	K0	K1	K2	*	0	1	1	0	: selects the number of digit set mode and specifies the number of digit value

K0 (LSB) to K2 (MSB) : number of digit data (3 bits: 8 digits)

\* : don't care

[Relation between setup data and controlled COM]

HEX	K0	K1	K2	Number of digits of COM
0	0	0	0	COM1 to 16
1	1	0	0	COM1 to 9
2	0	1	0	COM1 to 10
3	1	1	0	COM1 to 11
4	0	0	1	COM1 to 12
5	1	0	1	COM1 to 13
6	0	1	1	COM1 to 14
7	1	1	1	COM1 to 15

← (The state when power is turned on or when  $\overline{\text{RESET}}$  signal is input.)

7. All display lights ON/OFF set  
(turns all display lights ON or OFF)

All display lights ON is used primarily for display testing.

All display lights OFF is primarily used for display blink and to prevent malfunction when power is turned on.  
This command cannot control the general output port.

[Command format]

	LSB							MSB	
	B0	B1	B2	B3	B4	B5	B6	B7	
1st byte	L	H	*	*	1	1	1	0	: selects all display lights ON or OFF mode

L: sets all lights OFF

H: sets all lights ON

\*: Don't care

[Set data and display state of SEG and AD]

L	H	Display state of SEG and AD
0	0	Normal display
1	0	Sets all outputs to Low ← (The state when power is applied or when $\overline{\text{RESET}}$ is input.)
0	1	Sets all outputs to High
1	1	Sets all outputs to High ← (All lights ON mode has priority.)

**Setting Flowchart  
(Power applying included)**

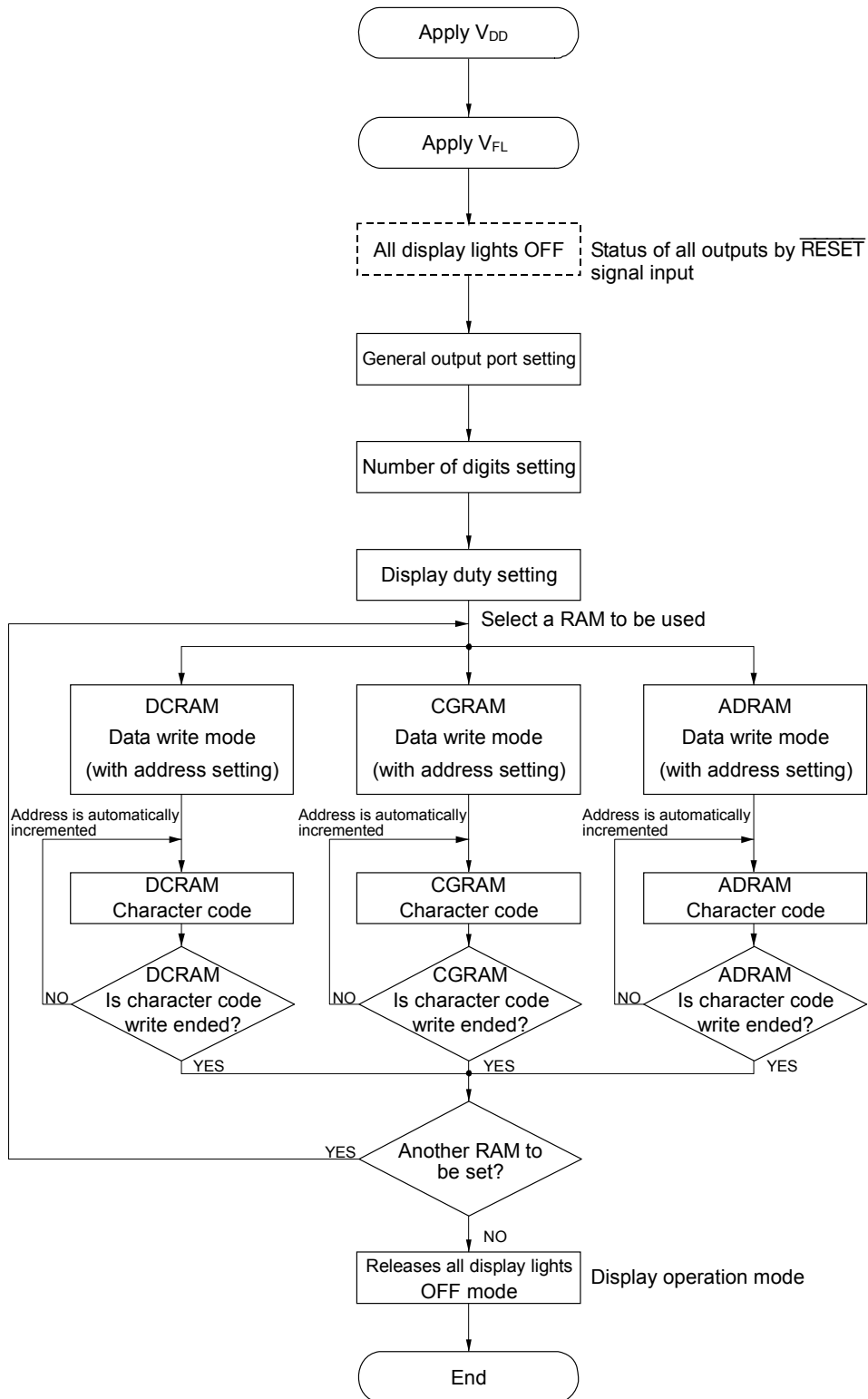

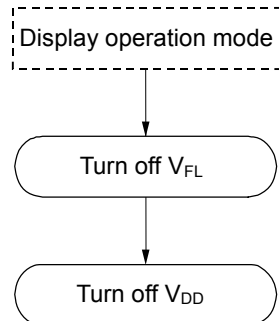
**Power-off Flowchart**

## POWER-ON/OFF TIMING

To prevent the IC from malfunctioning, turn on the logic power supply first, and then turn on the driver power supply when applying power. Also, for power-off, turn off the driver power supply first, then turn off the logic power supply.

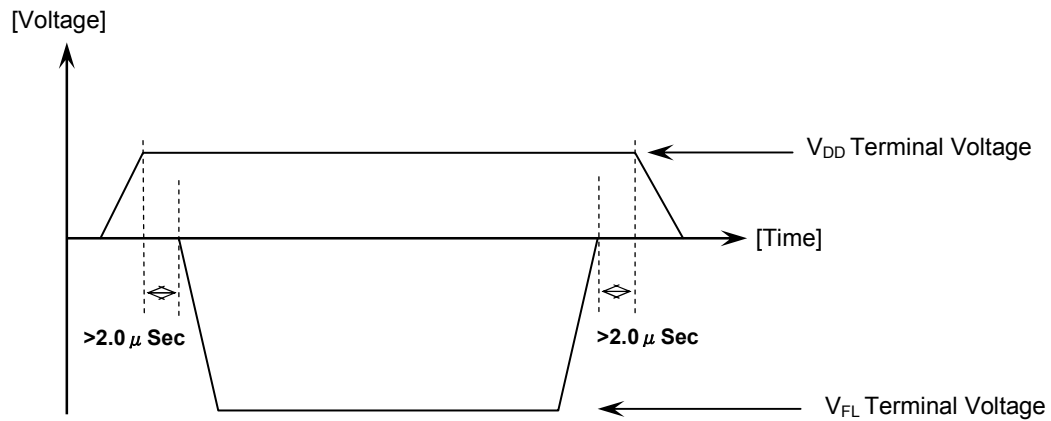

**APPLICATION CIRCUIT**

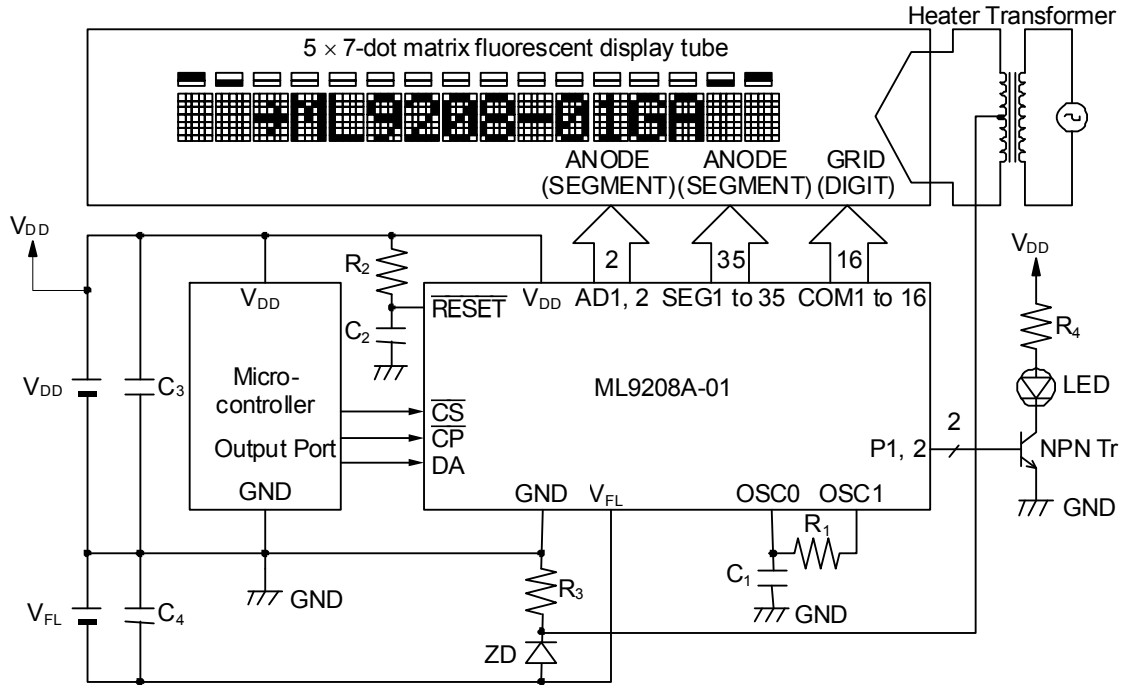

- Notes:
1. The  $V_{DD}$  value depends on the power supply voltage of the microcontroller used. Adjust the values of the constants  $R_1$ ,  $R_2$ ,  $R_4$ ,  $C_1$ , and  $C_2$  to the power supply voltage used.
  2. The  $V_{FL}$  value depends on the fluorescent display tube used. Adjust the values of the constants  $R_3$  and  $ZD$  to the power supply voltage used.

**Reference data**

The figure below shows the relationship between the  $V_{FL}$  voltage and the output current of each driver. Take care that the total power consumption to be used does not exceed the power dissipation.

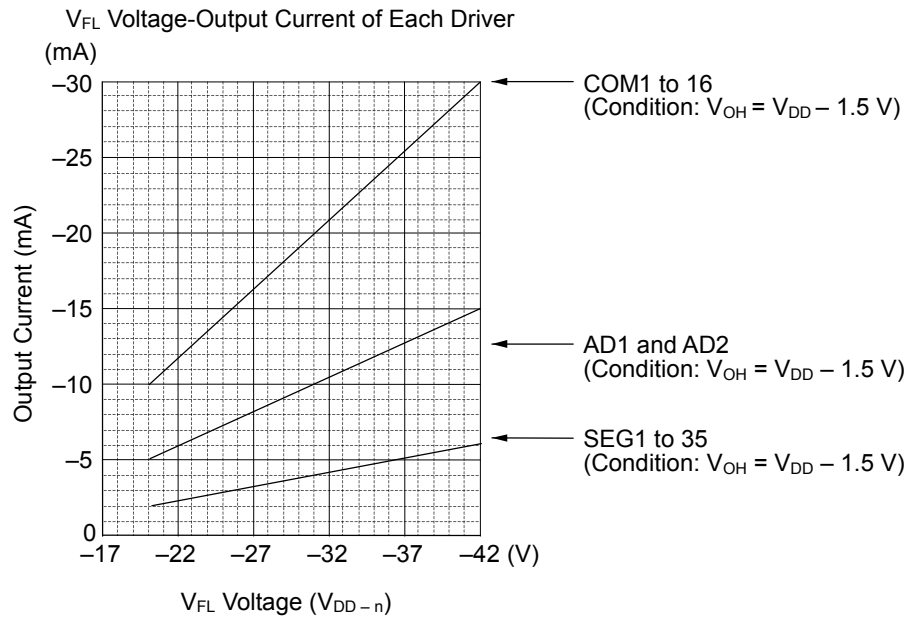

ML9208A-01 ROM CODE

\* ROM CODE is the character set for SEG1 to SEG35.

\*00000000b(00h) to 00000111b(07h) are the CGRAM addresses.

MSB LSB	0000	0001	0010	0011	0100	0101	0110	0111	1000	1001	1010	1011	1100	1101	1110	1111
0000	RAM0															
0001	RAM1															
0010	RAM2															
0011	RAM3															
0100	RAM4															
0101	RAM5															
0110	RAM6															
0111	RAM7															
1000																
1001																
1010																
1011																
1100																
1101																
1110																
1111																

**PACKAGE DIMENSIONS**

(Unit: mm)

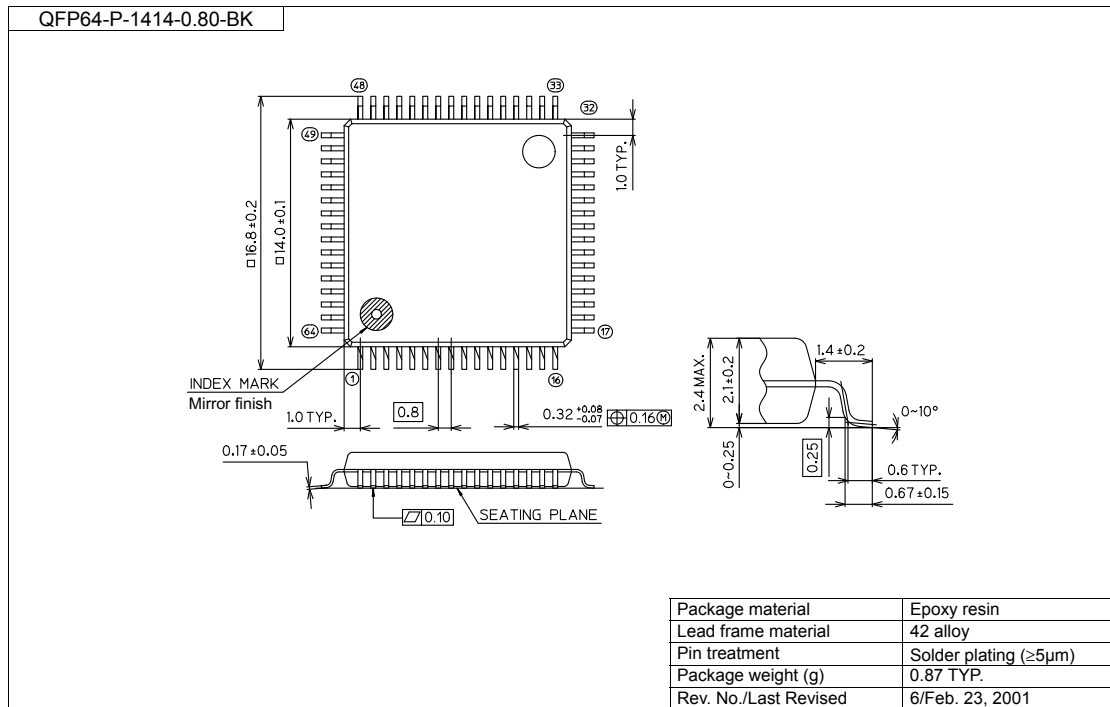

**Notes for Mounting the Surface Mount Type Package**

The surface mount type packages are very susceptible to heat in reflow mounting and humidity absorbed in storage. Therefore, before you perform reflow mounting, contact ROHM's responsible sales person for the product name, package name, pin number, package code and desired mounting conditions (reflow method, temperature and times).

(Unit: mm)

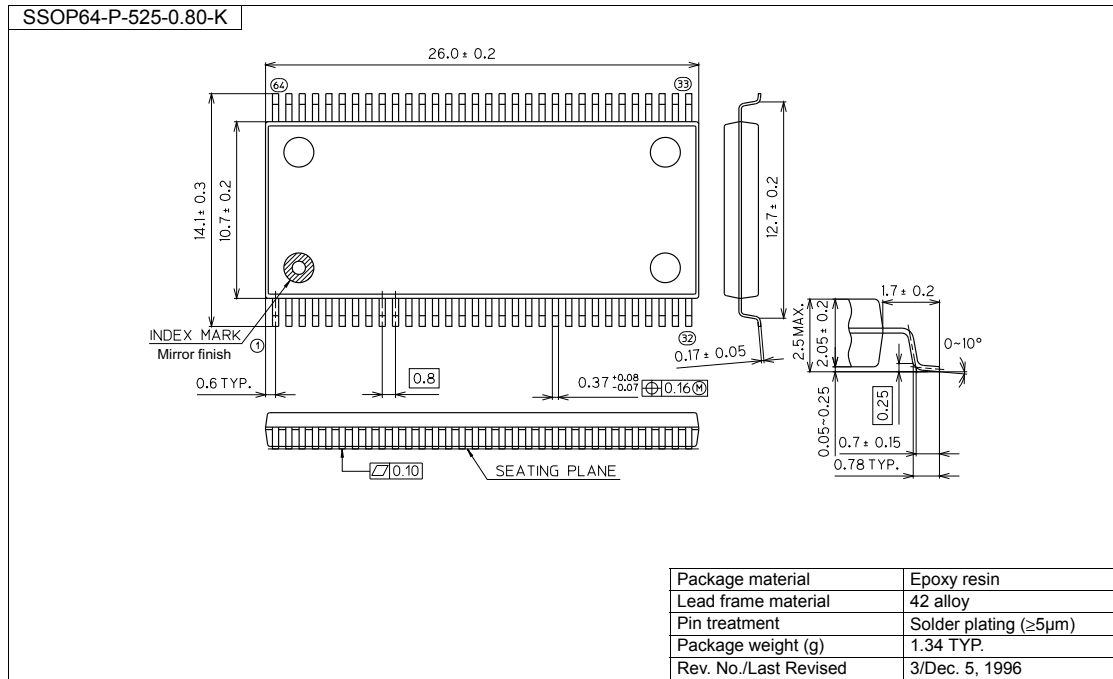

Notes for Mounting the Surface Mount Type Package

The surface mount type packages are very susceptible to heat in reflow mounting and humidity absorbed in storage. Therefore, before you perform reflow mounting, contact ROHM's responsible sales person for the product name, package name, pin number, package code and desired mounting conditions (reflow method, temperature and times).

(Unit: mm)

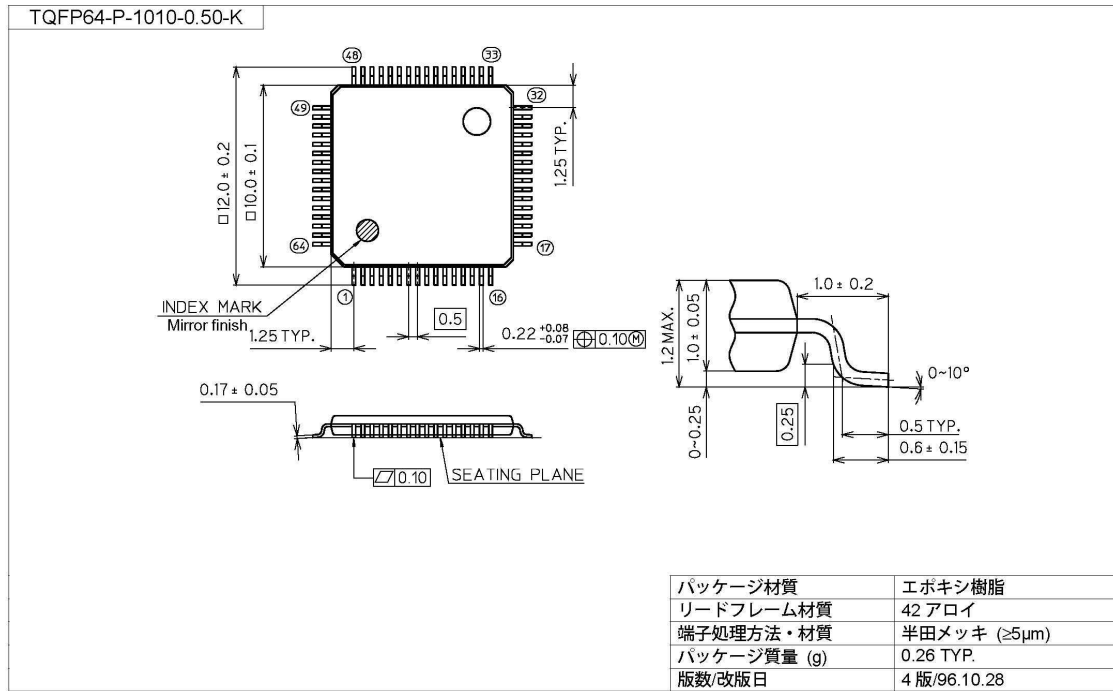

### Notes for Mounting the Surface Mount Type Package

The surface mount type packages are very susceptible to heat in reflow mounting and humidity absorbed in storage. Therefore, before you perform reflow mounting, contact ROHM's responsible sales person for the product name, package name, pin number, package code and desired mounting conditions (reflow method, temperature and times).

**REVISION HISTORY**

Document No.	Date	Page		Description
		Previous Edition	Current Edition	
FEDL9208A-01	Apr. 10, 2009	–	–	Final edition 1
FEDL9208A-02	Nov. 16, 2009	9	9	47pF→39 pF

## NOTICE

No copying or reproduction of this document, in part or in whole, is permitted without the consent of LAPIS Semiconductor Co., Ltd.

The content specified herein is subject to change for improvement without notice.

The content specified herein is for the purpose of introducing LAPIS Semiconductor's products (hereinafter "Products"). If you wish to use any such Product, please be sure to refer to the specifications, which can be obtained from LAPIS Semiconductor upon request.

Examples of application circuits, circuit constants and any other information contained herein illustrate the standard usage and operations of the Products. The peripheral conditions must be taken into account when designing circuits for mass production.

Great care was taken in ensuring the accuracy of the information specified in this document. However, should you incur any damage arising from any inaccuracy or misprint of such information, LAPIS Semiconductor shall bear no responsibility for such damage.

The technical information specified herein is intended only to show the typical functions of and examples of application circuits for the Products. LAPIS Semiconductor does not grant you, explicitly or implicitly, any license to use or exercise intellectual property or other rights held by LAPIS Semiconductor and other parties. LAPIS Semiconductor shall bear no responsibility whatsoever for any dispute arising from the use of such technical information.

The Products specified in this document are intended to be used with general-use electronic equipment or devices (such as audio visual equipment, office-automation equipment, communication devices, electronic appliances and amusement devices).

The Products specified in this document are not designed to be radiation tolerant.

While LAPIS Semiconductor always makes efforts to enhance the quality and reliability of its Products, a Product may fail or malfunction for a variety of reasons.

Please be sure to implement in your equipment using the Products safety measures to guard against the possibility of physical injury, fire or any other damage caused in the event of the failure of any Product, such as derating, redundancy, fire control and fail-safe designs. LAPIS Semiconductor shall bear no responsibility whatsoever for your use of any Product outside of the prescribed scope or not in accordance with the instruction manual.

The Products are not designed or manufactured to be used with any equipment, device or system which requires an extremely high level of reliability the failure or malfunction of which may result in a direct threat to human life or create a risk of human injury (such as a medical instrument, transportation equipment, aerospace machinery, nuclear-reactor controller, fuel-controller or other safety device). LAPIS Semiconductor shall bear no responsibility in any way for use of any of the Products for the above special purposes. If a Product is intended to be used for any such special purpose, please contact a ROHM sales representative before purchasing.

If you intend to export or ship overseas any Product or technology specified herein that may be controlled under the Foreign Exchange and the Foreign Trade Law, you will be required to obtain a license or permit under the Law.

Copyright 2009 - 2011 LAPIS Semiconductor Co., Ltd.