

Multi-contact (4-row, 128-contact) Connectors Expanding the DIN Concept

- Fully preserve the characteristics of normal DIN connectors while increasing the number of contacts available.
- Right-angle plug terminals of the standard DIN type and those vertically mounted on PCBs are available.
- Twin-contact sockets are used for high reliability and low insertion force.

RoHS Compliant

■ Ratings and Characteristics

Rated current	2 A
Rated voltage	300 VAC
Contact resistance	30 mΩ max. (at 20 mV, 100 mA max.)
Insulation resistance	10 ⁶ MΩ min. (at 100 VDC)
Dielectric strength	1,000 VAC for 1 min (leakage current: 1 mA max.)
Total insertion force	0.59 N max. per contact
Removal force	0.15 N min. (with test gauge, t = 0.56 mm)
Insertion durability	200 times
Ambient operating temperature	-55 to 125°C (with no icing at low temperature)

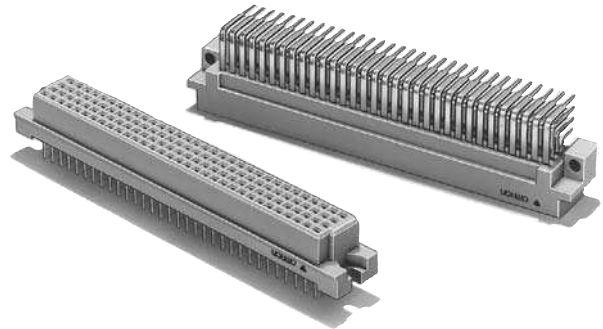

■ Materials and Finish

Type	Plugs	Sockets
Housings	Fiber-glass reinforced PBT resin (UL94 V-0)/gray	
Contacts	Mating end	Phosphor bronze/nickel base, 0.4-μm gold plating (See note.)
	Terminal	Phosphor bronze/nickel base, 2.0-μm tin plating

Note: For non-standard plating, contact your OMRON representative.

XC5M Four-row Plugs

■ Dimensions

(unit: mm)

XC5M-0222
(Standard DIN, with right-angle DIP terminals)

XC5M-0222-1
(DIN style 1, with right-angle DIP terminals)

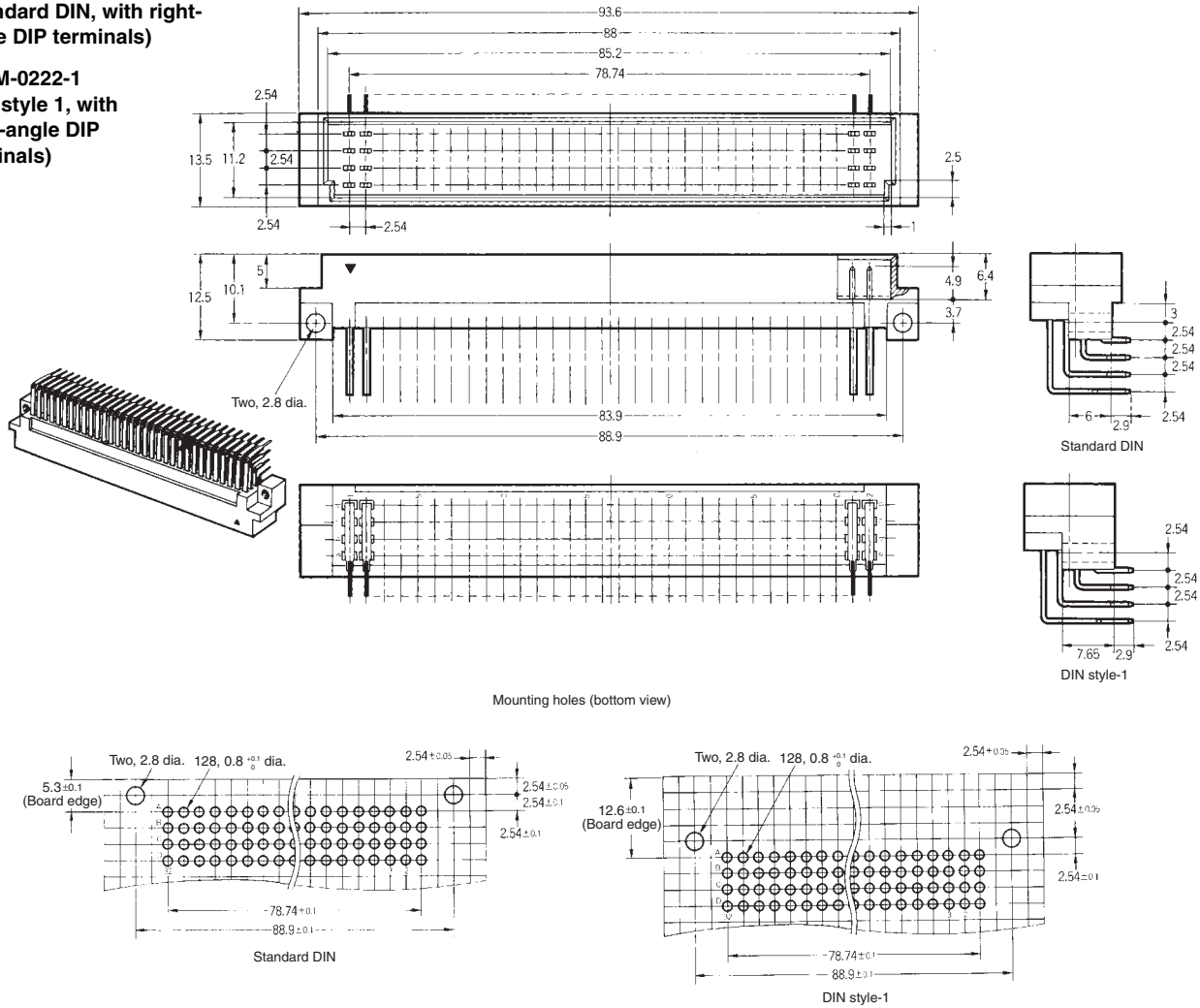

■ Ordering Information

No. of contacts	Housing	Model
128	Standard DIN	XC5M-0222
	DIN style 1	XC5M-0222-1

XC5N Four-row Sockets

■ Dimensions

(unit: mm)

XC5N-0221

(With straight DIP terminals)

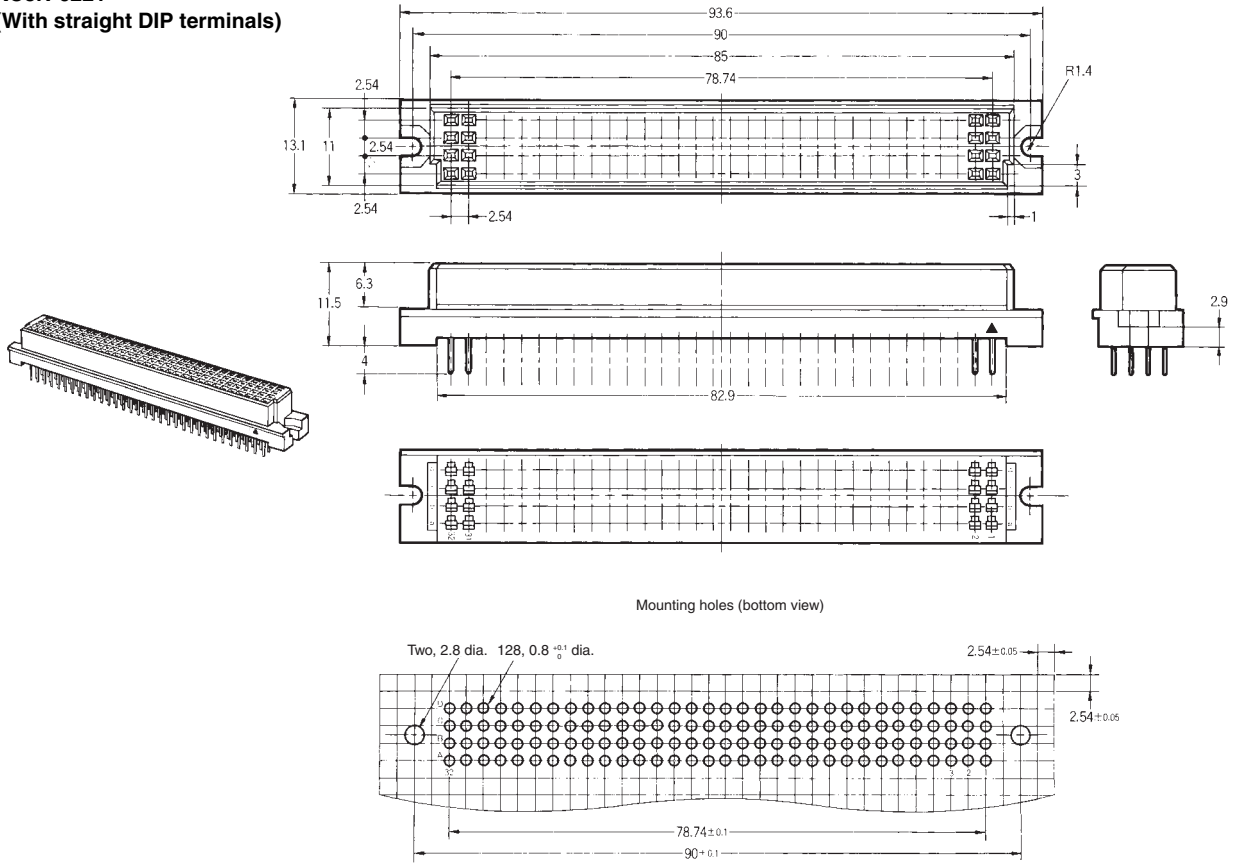

■ Ordering Information

No. of contacts	Terminal type	Model
128	Straight DIP terminals	XC5N-0221

■ Mating Diagrams

(unit: mm)

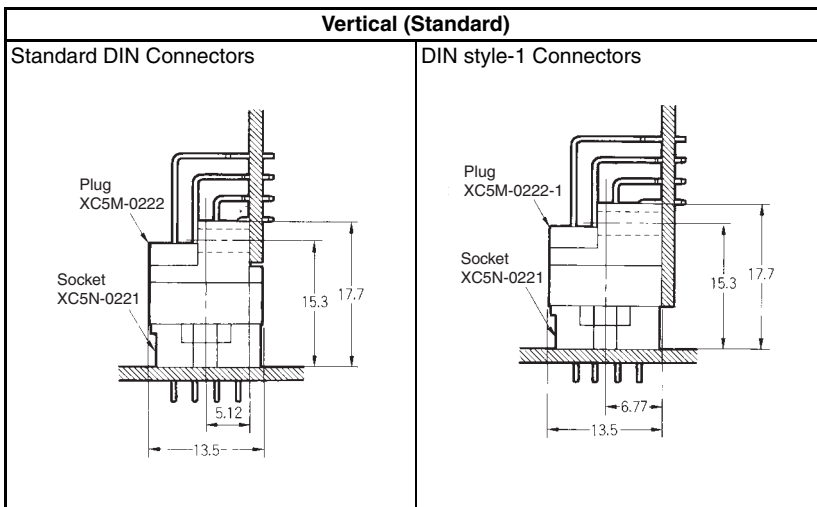

■ Precautions

Correct Use

Soldering

Automated Soldering

Before using automated soldering on a Connector that has right-angle terminals, mask the Connector (refer to the diagram).

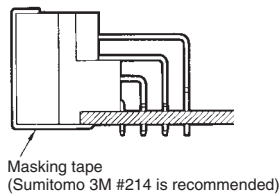

Mounting Position on PCB

When mounting right-angle terminals (DIN Style-1 Connectors) on a PCB, select a position where the PCB is not under the body of the Connector.

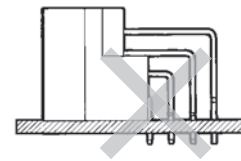

Automated Soldering Conditions (Jet Flow)

1. Soldering temperature: $250 \pm 5^\circ\text{C}$
2. Continuous soldering time: Within 5 ± 1 s

• Application examples provided in this document are for reference only. In actual applications, confirm equipment functions and safety before using the product.
 • Consult your OMRON representative before using the product under conditions which are not described in the manual or applying the product to nuclear control systems, railroad systems, aviation systems, vehicles, combustion systems, medical equipment, amusement machines, safety equipment, and other systems or equipment that may have a serious influence on lives and property if used improperly. Make sure that the ratings and performance characteristics of the product provide a margin of safety for the system or equipment, and be sure to provide the system or equipment with double safety mechanisms.

Note: Do not use this document to operate the Unit.

OMRON Corporation
 Electronic and Mechanical Components Company

Contact: www.omron.com/ecb

Cat. No. G052-E1-02
 1014(0412)(O)