

## Photomicrosensor (Transmissive) EE-SX1109

 Be sure to read *Precautions* on page 25.

### ■ Dimensions

**Note:** All units are in millimeters unless otherwise indicated.

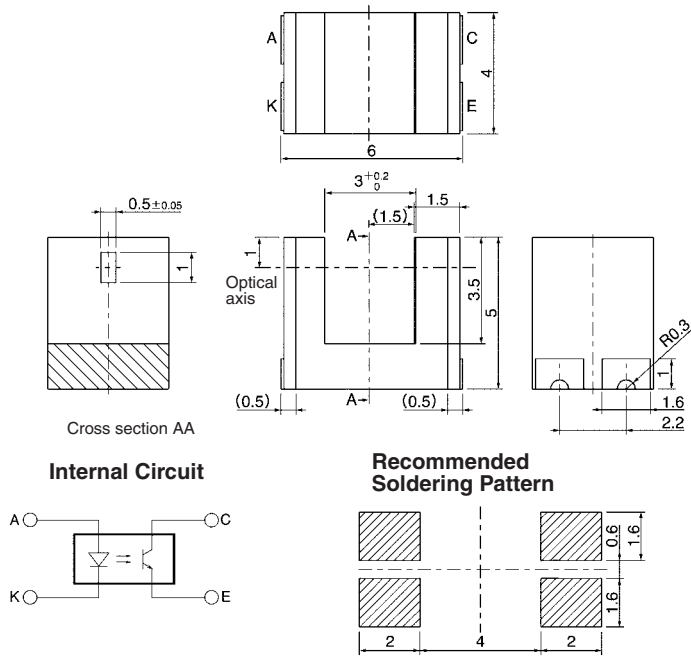

Terminal No.	Name
A	Anode
K	Cathode
C	Collector
E	Emitter

Unless otherwise specified, the tolerances are  $\pm 0.15$  mm.

### ■ Features

- Ultra-compact with a 6-mm-wide sensor and a 3-mm-wide slot.
- PCB surface mounting type.
- High resolution with a 0.5-mm-wide aperture.

### ■ Absolute Maximum Ratings ( $T_a = 25^\circ\text{C}$ )

Item	Symbol	Rated value
Emitter	Forward current	$I_F$ 25 mA (see note 1)
	Pulse forward current	$I_{FP}$ 100 mA (see note 2)
	Reverse voltage	$V_R$ 5 V
Detector	Collector–Emitter voltage	$V_{CEO}$ 20 V
	Emitter–Collector voltage	$V_{ECO}$ 5 V
	Collector current	$I_C$ 20 mA
	Collector dissipation	$P_C$ 75 mW (see note 1)
	Ambient temperature	Operating
	Storage	$T_{stg}$ –40°C to 90°C
	Reflow soldering	$T_{sol}$ 255°C (see note 3)
	Manual soldering	$T_{sol}$ 350°C (see note 3)

**Note:** 1. Refer to the temperature rating chart if the ambient temperature exceeds 25°C.

2. Duty: 1/100; Pulse width: 0.1 ms

3. Complete soldering within 10 seconds for reflow soldering and within 3 seconds for manual soldering.

### ■ Electrical and Optical Characteristics ( $T_a = 25^\circ\text{C}$ )

Item	Symbol	Value	Condition
Emitter	Forward voltage	$V_F$	1.1 V typ., 1.3 V max.
	Reverse current	$I_R$	10 $\mu\text{A}$ max.
	Peak emission wavelength	$\lambda_p$	940 nm typ.
Detector	Light current	$I_L$	50 $\mu\text{A}$ min., 150 $\mu\text{A}$ typ., 500 $\mu\text{A}$ max.
	Dark current	$I_D$	100 nA max.
	Leakage current	$I_{LEAK}$	---
	Collector–Emitter saturated voltage	$V_{CE(sat)}$	0.1 V typ., 0.4 V max.
	Peak spectral sensitivity wavelength	$\lambda_p$	900 nm typ.
Rising time	$t_r$	10 $\mu\text{s}$ typ.	$V_{CC} = 5$ V, $R_L = 1$ k $\Omega$ , $I_L = 100$ $\mu\text{A}$
Falling time	$t_f$	10 $\mu\text{s}$ typ.	$V_{CC} = 5$ V, $R_L = 1$ k $\Omega$ , $I_L = 100$ $\mu\text{A}$

# Engineering Data

**Forward Current vs. Collector Dissipation Temperature Rating**

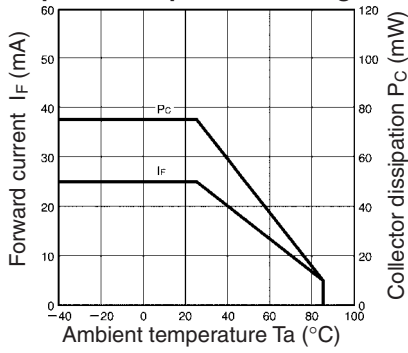

**Forward Current vs. Forward Voltage Characteristics (Typical)**

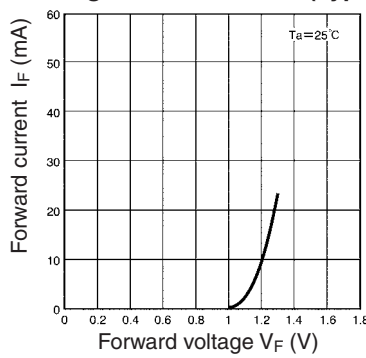

**Light Current vs. Forward Current Characteristics (Typical)**

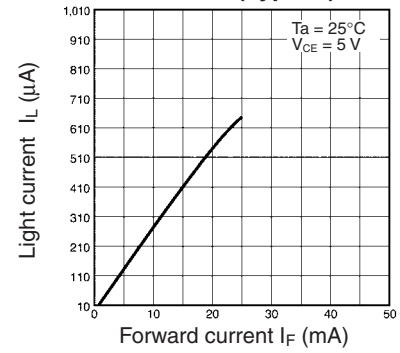

**Light Current vs. Collector-Emitter Voltage Characteristics (Typical)**

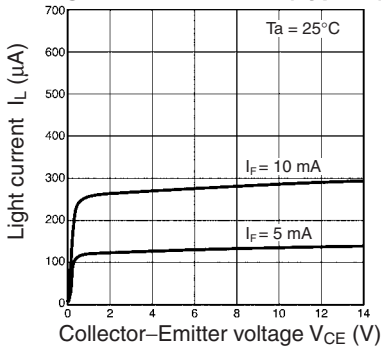

**Relative Light Current vs. Ambient Temperature Characteristics (Typical)**

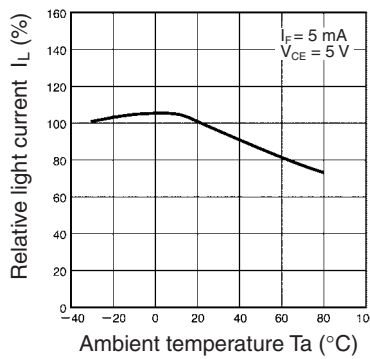

**Dark Current vs. Ambient Temperature Characteristics (Typical)**

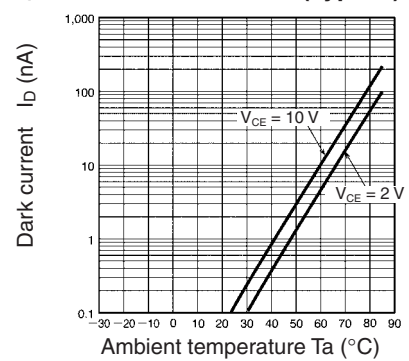

**Response Time vs. Load Resistance Characteristics (Typical)**

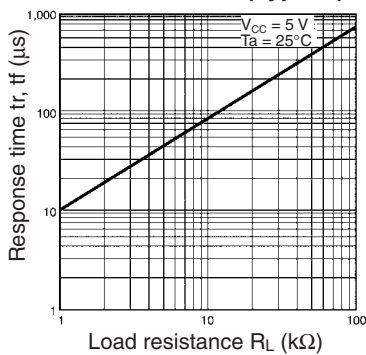

**Sensing Position Characteristics (Typical)**

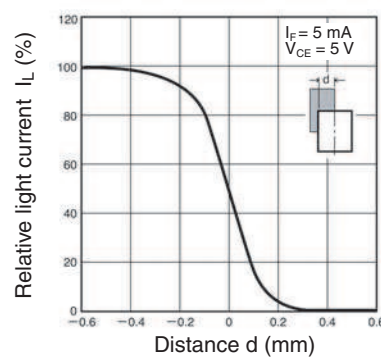

**Sensing Position Characteristics (Typical)**

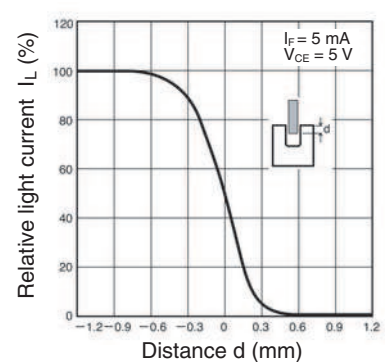

**Response Time Measurement Circuit**

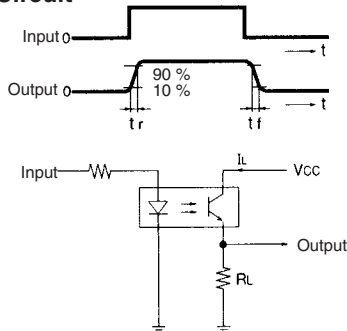

Unit: mm (inch)

## ■ Tape and Reel

### Reel

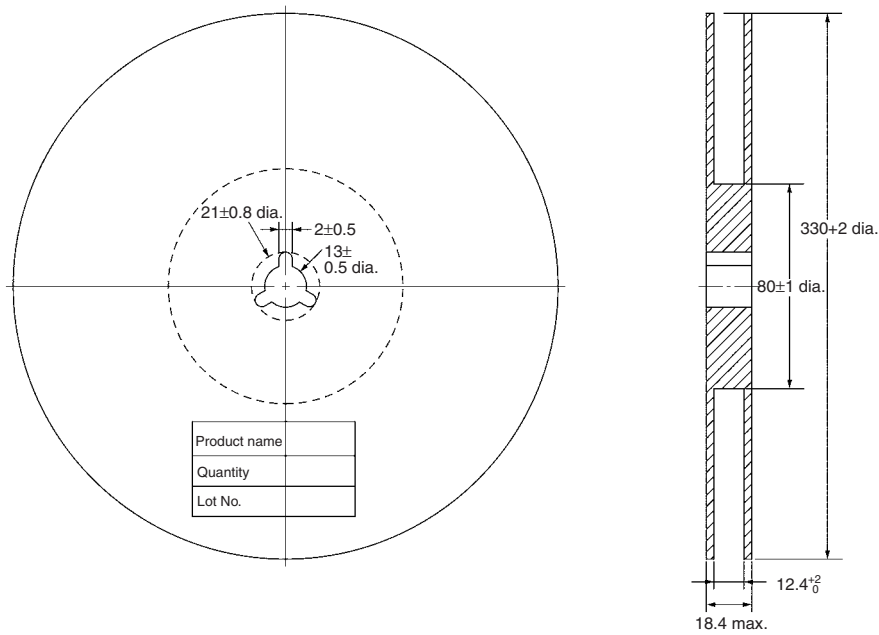

### Tape

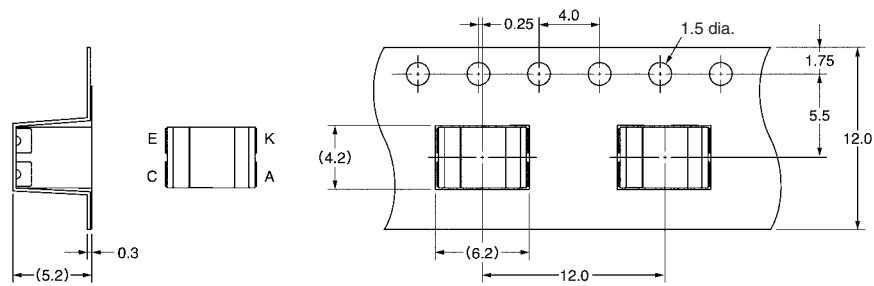

### Tape configuration

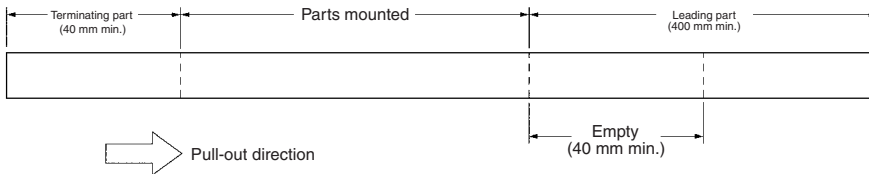

### Tape quantity

1,000 pcs./reel

# Precautions

## ■ Soldering Information

### Reflow soldering

- The following soldering paste is recommended:  
Melting temperature: 216 to 220°C  
Composition: Sn 3.5 Ag 0.75 Cu
- The recommended thickness of the metal mask for screen printing is between 0.2 and 0.25 mm.
- Set the reflow oven so that the temperature profile shown in the following chart is obtained for the upper surface of the product being soldered.

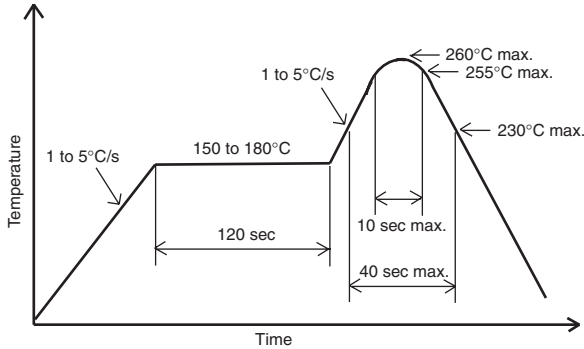

### Manual soldering

- Use "Sn 60" (60% tin and 40% lead) or solder with silver content.
- Use a soldering iron of less than 25 W, and keep the temperature of the iron tip at 300°C or below.
- Solder each point for a maximum of three seconds.
- After soldering, allow the product to return to room temperature before handling it.

### Storage

To protect the product from the effects of humidity until the package is opened, dry-box storage is recommended. If this is not possible, store the product under the following conditions:

Temperature: 10 to 30°C

Humidity: 60% max.

The product is packed in a humidity-proof envelope. Reflow soldering must be done within 48 hours after opening the envelope, during which time the product must be stored under 30°C at 80% maximum humidity.

If it is necessary to store the product after opening the envelope, use dry-box storage or reseal the envelope.

### Baking

If a product has remained packed in a humidity-proof envelope for six months or more, or if more than 48 hours have lapsed since the envelope was opened, bake the product under the following conditions before use:

Reel: 60°C for 24 hours or more

Bulk: 80°C for 4 hours or more