

### Specifications

Specifications	Units	PTM-24F		
Rated Voltage	V	24	100	200
Frequency	Hz	50/60		
Rated Current	mA	150/160	35/45	30/25
Revolutions	rpm	250/300		
Rotating Direction		Dual Direction (CC/CCW)		
Torque @ 60Hz	mN-m	35/30		
Temperature Rise	K	55		
Operating Temp. Range	°C	-10 to +50		
Dielectric Strength	V	500Vac for 1 min.	1000Vac for 1 min.	1500Vac for 1 min.
Weight	g	300		
Capacitor	µF	6.8	0.47	0.11

Magnet type: Anisotropic

### Gearred Models

#### PTM-24FG

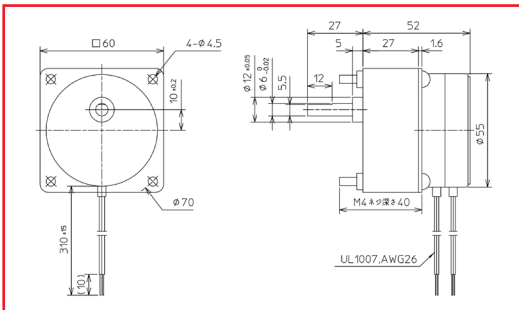

Gear Ratio	L
1/3 ~ 1/8	32
1/20 ~ 1/180	42

#### PTM-24FG(BB)

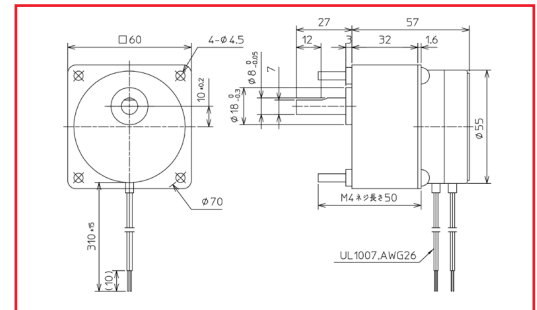

### Geared Motor Torque Characteristics

Model	PTM-24FG			
	Torque (mN-m)		Gear Ratio	
	50Hz	60Hz	50Hz	60Hz
60	93	95	6/25	1/5
30	185	190	3/25	1/10
20	280	285	2/25	1/15
10	445	460	1/25	1/30
5	700*	700*	1/50	1/60
4	895	920	2/125	1/75
3	1000*	1000*	3/250	1/100
2	1000*	1000*	1/125	1/150
1	1000*	1000*	1/250	1/300

Values regulated by normal gear strength. Do not apply any load exceeding the normal gear strength.

Model	PTM-24FG(BB)			
	Torque (mN-m)		Gear Ratio	
	50Hz	60Hz	50Hz	60Hz
60	--	96	--	1/5
30	--	190	--	1/10
20	280	285	2/25	1/15
10	445	460	1/25	1/30
5	895	920	1/50	1/60
4	--	970	--	1/75
3	1150	1200	3/250	1/100
2	1750	1800	1/125	1/150
1	--	--	--	--

## Dual Direction Synchronous Motors

**PTM(C) - 24 F 3 4 G 1/2**  
 1 2 3 4 5 6 7

### 1 - Series Designation

PTM: Flying lead joint type  
 PTMC: Connector joint type

### 2 - Number of Poles

12: Speed is 500 rpm w/50Hz  
 Speed is 600 rpm w/60Hz  
 24: Speed is 250 rpm w/50Hz  
 Speed is 300 rpm w/60Hz

### 3 - Outer Diameter (Type)

P: 22mm, M: 35mm, T: 35mm  
 (thin), H: 42mm, S: 42mm  
 (thin), F: 55mm, R: 55mm (w/  
 connector)

### 4 - Coil Specification

Blank: Standard Coil  
 (continuous for 24, 100, 200 Vac)  
 1-18: Coil # for specific rating

### 5 - Magnet Type

Blank: Anisotropic  
 3: Isotropic  
 4: Neodymium  
 5: Plastic

### 6 - Gear Head

Blank: No Gear Head  
 G: Gear Head Integrated

### 7 - Gear Ratio

see chart below

Gear Ratio	rpm w/12 poles		rpm w/24 poles	
	50Hz	60Hz	50Hz	60 Hz
Motor only	500	600	250	300
1/10	50	60	25	30
1/50	10	12	5	6
1/100	5	6	2.5	3

## Dual Direction Synchronous Motors

Motors that move in two directions are capacitor-based phase advancing motors. Because the rotor is moved by shifting the phase current by 90° it is essential for the circuit to have a capacitor. The proper wiring is below.

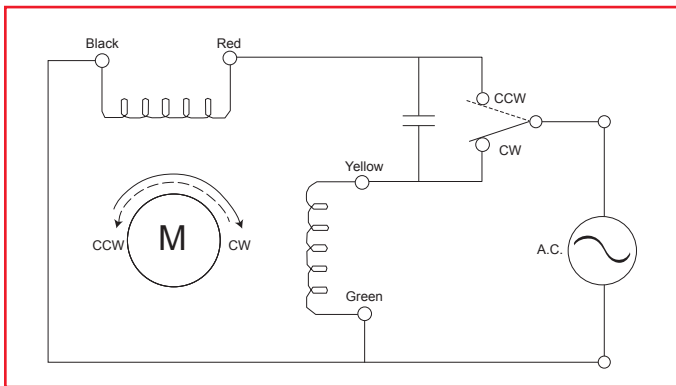

As viewed from the output shaft of the motor

## About Synchronous Motors

### No Power or Load Fluctuation Effect

Synchronous motors rotate in synch with supplied power frequency. If power frequency is constant, the motor will rotate at a constant speed (synchronized speed).

### Impedance Protected

Unless otherwise stated, these motors provide high electrical resistance, which prevents overcurrent from flowing to the motor, which would in turn burn the coils.

### No Control Circuit Required

Because these motors are AC motors, they start rotating when a power connection is made.

### Excellent Response

The type of magnet used in these motors ensures excellent response and also ensures the motor will start and stop immediately when power is supplied or removed.