

### Specifications

| Specifications        | Unit              | PF35T-48               |     |         |     |
|-----------------------|-------------------|------------------------|-----|---------|-----|
| Type of Winding       |                   | Unipolar               |     | Bipolar |     |
| Excitation Mode*      |                   | Full step (2-2)        |     |         |     |
| Step Angle            | °                 | 7.5 ± 5%               |     |         |     |
| Steps Per Revolution* |                   | 48                     |     |         |     |
| Rated Voltage         | V                 | 12                     | 5   | 12      | 5   |
| Resistance            | Ω                 | 70                     | 12  | 72      | 16  |
| Inductance            | mH                | 30                     | 6.5 | 60      | 6.2 |
| Holding Torque        | mN·m              | 18                     | 18  | 27      | 27  |
| Rotor Inertia         | kg·m <sup>2</sup> | 2.7 x 10 <sup>-7</sup> |     |         |     |
| Starting Pulse Rate*  | pps               | 600                    |     |         |     |
| Slewing Pulse Rate*   | pps               | 610                    |     |         |     |
| Operating Temp. Range | °C                | -10 to +50             |     |         |     |
| Temperature Rise*     | °C                | 70                     |     |         |     |
| Weight                | g                 | 77                     |     |         |     |

### Dimensions of Geared Model

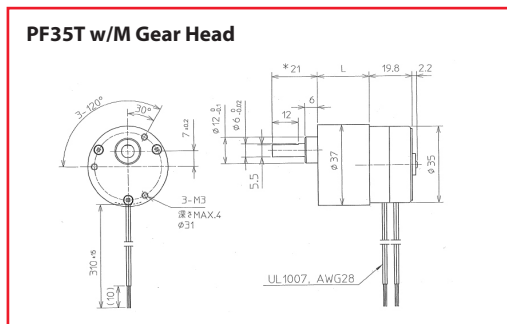

|       | L2   |
|-------|------|
| PF35  | 19.1 |
| PF35T | 13.5 |

| Gear Ratio         | 1/5     | 1/6 | 1/10 | 1/18    | 1/30 |
|--------------------|---------|-----|------|---------|------|
| Ordinary Torque    | 100mN·m |     |      | 200mN·m |      |
| Destruction Torque | 300mN·m |     |      | 600mN·m |      |

| Gear Ratio         | 1/40    | 1/50 | 1/60 | 1/75 | 1/90 | 1/100 | 1/120 |
|--------------------|---------|------|------|------|------|-------|-------|
| Ordinary Torque    | 300mN·m |      |      |      |      |       |       |
| Destruction Torque | 900mN·m |      |      |      |      |       |       |

| Gear Ratio         | 1/125    | 1/150 | 1/180 | 1/200 | 1/270 | 1/300 |
|--------------------|----------|-------|-------|-------|-------|-------|
| Ordinary Torque    | 600mN·m  |       |       |       |       |       |
| Destruction Torque | 1800mN·m |       |       |       |       |       |

| Gear Ratio | 1/5  | 1/6  | 1/10 | 1/18 | 1/30 | 1/40 | 1/50 | 1/60 | 1/75 | 1/90 | 1/100 | 1/120 | 1/125 | 1/150 | 1/180 | 1/200 | 1/270 | 1/300 |
|------------|------|------|------|------|------|------|------|------|------|------|-------|-------|-------|-------|-------|-------|-------|-------|
| L1         | 19.5 | 19.5 | 19.5 | 19.5 | 21.7 | 21.7 | 21.7 | 21.7 | 21.7 | 21.7 | 21.7  | 21.7  | 23.8  | 23.8  | 23.8  | 23.8  | 23.8  | 23.8  |

### Torque Curve (pull-out torque)\* Bipolar Constant Voltage (48R1)

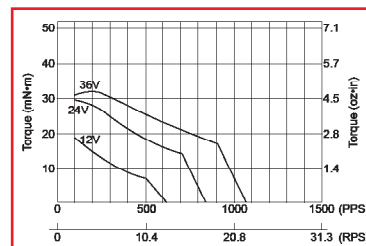

Coil Resistance: 72Ω

### Bipolar Constant Current (48Q1)

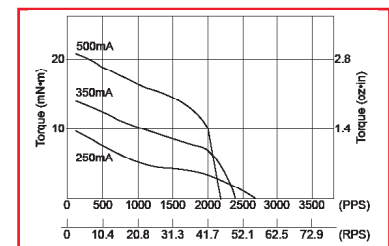

Coil Resistance: 16Ω Supply Voltage: 24V

### Unipolar Constant Voltage (48C1)

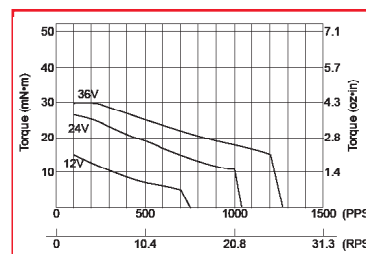

Coil Resistance: 70Ω

### Unipolar Constant Current (48D1)

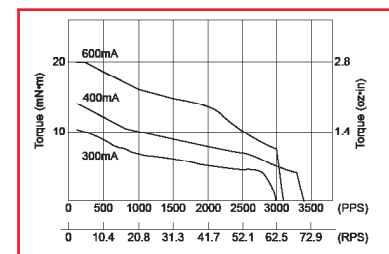

Coil Resistance: 12Ω Supply Voltage: 24V

Note: Torque curves are for reference only and are not guaranteed.  
All tin-can motor specifications are based on full-step constant voltage operation  
Magnet type: Anisotropic