



The PCD2112 for stepper or servo motors adopts a 4-wire serial bus and incorporates advanced features into a miniaturized package, enabling easy downsizing of the control board.

This pulse generator can also operate without a CPU in standalone mode by connecting to an external EEPROM, into which up to 32 operating patterns can be written.

These features make this ASIC the ultimate in portable motion control.

### Features:

- Sequencer output (Unipolar/Bipolar) (Half/Full Step)
- Linear and S-curve acceleration/deceleration control
- Anti-jerk correction
- Built-in homing routines
- Simultaneous start/stop of multiple ICs
- On-the-fly override of speed or target position
- General-purpose I/O (4 bits, 2 fixed to output)

### Applications:

- Embedded motion control
- Portable controllers
- Field-programmable controllers

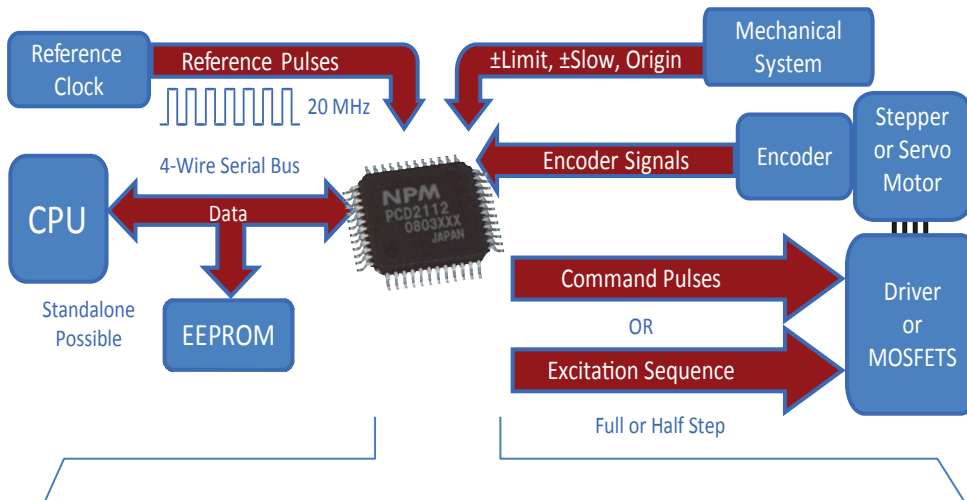

PCD2112  
(Actual Size)

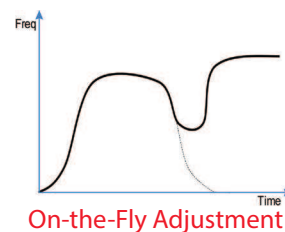
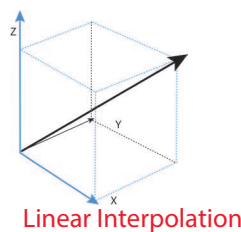
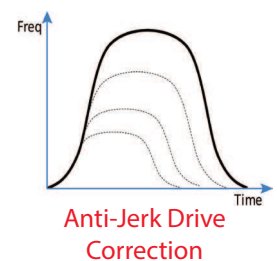
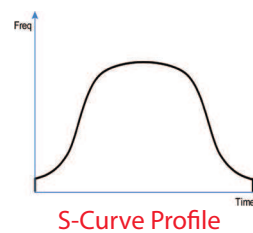
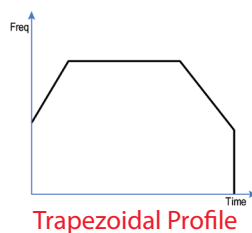
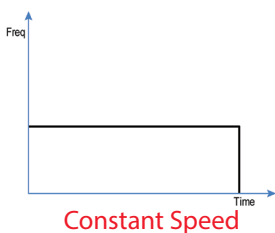

## General Specifications

Item	Description
Available Configurations	1 axis
Max Output Speed	5 Mpps (with 20 MHz reference clock)
Position Range	0 to 268,435,455 pulses (28 bits)
Speed Range	1 to 8,191 steps (13 bits)
Acceleration Rate Range	1 to 65,535 (16 bits)
Deceleration Rate Range	1 to 65,535 (16 bits)
Mechanical Sensor Input	ORG, +EL, -EL, SD
Excitation Sequence Output	Full/Half step
Pulse Output	CW/CCW Pulse/Direction
Servomotor I/F	INP, ERC, ALM servomotor inputs
Encoder Input Max Frequency	1.7 MHz (with 20 MHz reference clock)
Typical operations	<ul style="list-style-type: none"> <li>- Continuous operation</li> <li>- Positioning operation</li> <li>- Continuous operation using a <math>\pm</math>DR switch - Origin return operation</li> <li>- Timer operation</li> <li>- Continuous operation using a pulsar input</li> </ul>
Typical functions	<ul style="list-style-type: none"> <li>- Immediate stop and decelerating stop</li> <li>- Speed change</li> <li>- External start and external stop function</li> <li>- Triangle drive suppression</li> </ul>
Number of Registers for Speed Setting	3 (FL, FH1, FH2)
CPU Interface	4-wire serial bus
Power Supply	3.0 to 3.6 V
Package	Package 48-pin QFP (molded package: 7 x 7 mm)
Chip design	CMOS (Complementary Metal-Oxide Semiconductor)

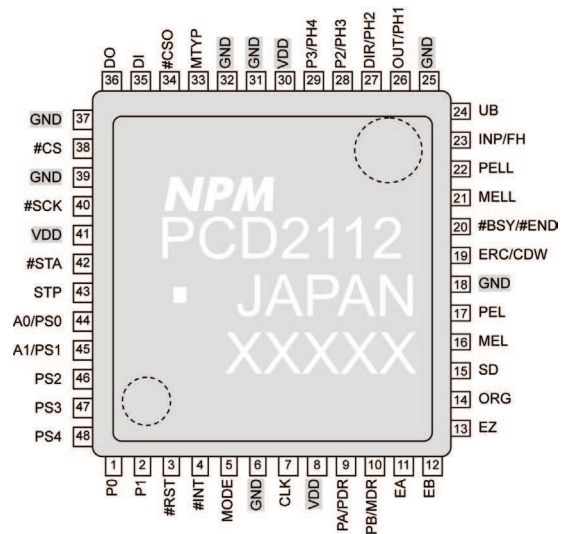
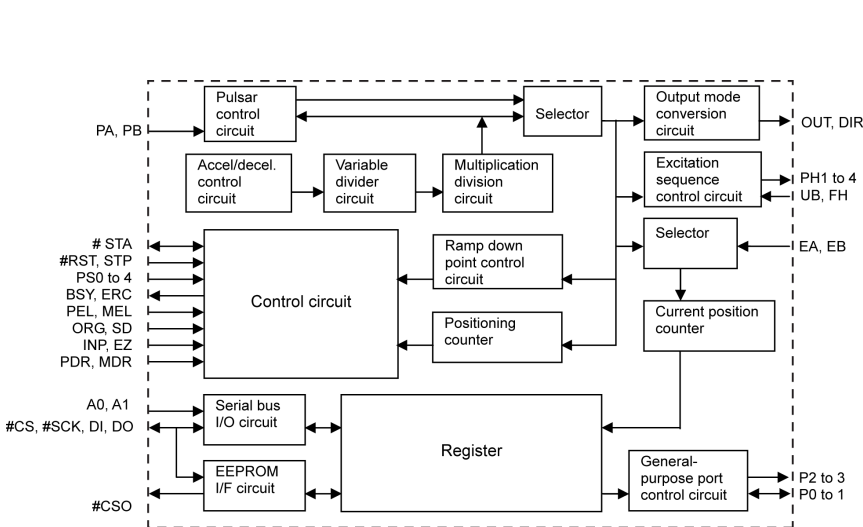

Note: Check the position of each pin number by referring to the markings. As shown in the figure above, pin 1 is in the lower left corner of the chip.

# NPM

Nippon Pulse

Your Partner in Motion Control