

**PDP TRENCH IGBT**

# IRG7S319UPbF

**Features**

- Advanced Trench IGBT Technology
- Optimized for Sustain and Energy Recovery circuits in PDP applications
- Low  $V_{CE(on)}$  and Energy per Pulse ( $E_{PULSE}^{TM}$ ) for improved panel efficiency
- High repetitive peak current capability
- Lead Free package

Key Parameters		
$V_{CE\ min}$	330	V
$V_{CE(ON)}\ typ.\ @\ I_C = 20A$	1.26	V
$I_{RP}\ max\ @\ T_C = 25^\circ C$	170	A
$T_J\ max$	150	$^\circ C$

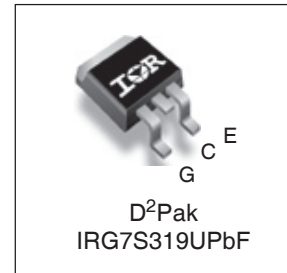
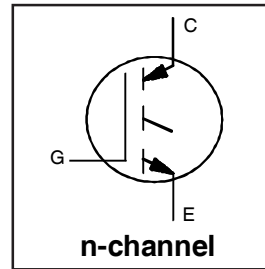

G	C	E
Gate	Collector	Emitter

**Description**

This IGBT is specifically designed for applications in Plasma Display Panels. This device utilizes advanced trench IGBT technology to achieve low  $V_{CE(on)}$  and low  $E_{PULSE}^{TM}$  rating per silicon area which improve panel efficiency. Additional features are 150 $^\circ C$  operating junction temperature and high repetitive peak current capability. These features combine to make this IGBT a highly efficient, robust and reliable device for PDP applications.

**Absolute Maximum Ratings**

	Parameter	Max.	Units
$V_{GE}$	Gate-to-Emitter Voltage	$\pm 30$	V
$I_C @ T_C = 25^\circ C$	Continuous Collector Current, $V_{GE} @ 15V$	45	A
$I_C @ T_C = 100^\circ C$	Continuous Collector, $V_{GE} @ 15V$	20	
$I_{RP} @ T_C = 25^\circ C$	Repetitive Peak Current ①	170	W
$P_D @ T_C = 25^\circ C$	Power Dissipation	96	
$P_D @ T_C = 100^\circ C$	Power Dissipation	38	$W/^\circ C$
	Linear Derating Factor	0.77	
$T_J$ $T_{STG}$	Operating Junction and Storage Temperature Range	-40 to + 150	
	Soldering Temperature for 10 seconds	300	$^\circ C$

**Thermal Resistance**

	Parameter	Typ.	Max.	Units
$R_{\theta JC}$	Junction-to-Case ②	—	1.3	$^\circ C/W$

## Electrical Characteristics @ $T_J = 25^\circ\text{C}$ (unless otherwise specified)

	Parameter	Min.	Typ.	Max.	Units	Conditions
$BV_{CES}$	Collector-to-Emitter Breakdown Voltage	330	—	—	V	$V_{GE} = 0V, I_{CE} = 250\mu A$
$\Delta BV_{CES}/\Delta T_J$	Breakdown Voltage Temp. Coefficient	—	0.38	—	V/°C	Reference to $25^\circ\text{C}, I_{CE} = 1\text{mA}$
$V_{CE(on)}$	Static Collector-to-Emitter Voltage	—	1.26	1.43	V	$V_{GE} = 15V, I_{CE} = 20A$ ③
		—	1.34	—		$V_{GE} = 15V, I_{CE} = 25A$ ③
		—	1.65	—		$V_{GE} = 15V, I_{CE} = 45A$ ③
		—	2.02	—		$V_{GE} = 15V, I_{CE} = 70A$ ③
		—	2.79	—		$V_{GE} = 15V, I_{CE} = 120A$ ③
		—	1.39	—		$V_{GE} = 15V, I_{CE} = 25A, T_J = 150^\circ\text{C}$ ③
$V_{GE(th)}$	Gate Threshold Voltage	2.2	—	4.7	V	$V_{CE} = V_{GE}, I_{CE} = 1.3\text{mA}$
$\Delta V_{GE(th)}/\Delta T_J$	Gate Threshold Voltage Coefficient	—	-8.8	—	mV/°C	
$I_{CES}$	Collector-to-Emitter Leakage Current	—	1.0	20	$\mu A$	$V_{CE} = 330V, V_{GE} = 0V$
		—	50	200		$V_{CE} = 330V, V_{GE} = 0V, T_J = 125^\circ\text{C}$
		—	125	—		$V_{CE} = 330V, V_{GE} = 0V, T_J = 150^\circ\text{C}$
$I_{GES}$	Gate-to-Emitter Forward Leakage	—	—	100	nA	$V_{GE} = 30V$
	Gate-to-Emitter Reverse Leakage	—	—	-100		$V_{GE} = -30V$
$g_{fe}$	Forward Transconductance	—	55	—	S	$V_{CE} = 25V, I_{CE} = 25A$
$Q_g$	Total Gate Charge	—	38	—	nC	$V_{CE} = 200V, I_C = 25A, V_{GE} = 15V$ ③
$Q_{gc}$	Gate-to-Collector Charge	—	13	—		
$t_{d(on)}$	Turn-On delay time	—	16	—	ns	$I_C = 25A, V_{CC} = 196V$ $R_G = 10\Omega, L = 200\mu H$ $T_J = 25^\circ\text{C}$
$t_r$	Rise time	—	22	—		
$t_{d(off)}$	Turn-Off delay time	—	81	—		
$t_f$	Fall time	—	105	—		
$t_{d(on)}$	Turn-On delay time	—	16	—	ns	$I_C = 25A, V_{CC} = 196V$ $R_G = 10\Omega, L = 200\mu H$ $T_J = 150^\circ\text{C}$
$t_r$	Rise time	—	25	—		
$t_{d(off)}$	Turn-Off delay time	—	95	—		
$t_f$	Fall time	—	203	—		
$t_{st}$	Shoot Through Blocking Time	100	—	—	ns	$V_{CC} = 240V, V_{GE} = 15V, R_G = 5.1\Omega$
$E_{PULSE}$	Energy per Pulse	—	854	—	$\mu J$	$L = 220\text{nH}, C = 0.40\mu F, V_{GE} = 15V$ $V_{CC} = 240V, R_G = 5.1\Omega, T_J = 25^\circ\text{C}$
		—	1083	—		$L = 220\text{nH}, C = 0.40\mu F, V_{GE} = 15V$ $V_{CC} = 240V, R_G = 5.1\Omega, T_J = 100^\circ\text{C}$
ESD	Human Body Model	Class 1C (Per JEDEC standard JESD22-A114)				
	Machine Model	Class B (Per EIA/JEDEC standard EIA/JESD22-A115)				
$C_{ies}$	Input Capacitance	—	1098	—	pF	$V_{GE} = 0V$
$C_{oes}$	Output Capacitance	—	56	—		$V_{CE} = 30V$
$C_{res}$	Reverse Transfer Capacitance	—	32	—		$f = 1.0\text{MHz}$
$L_C$	Internal Collector Inductance	—	4.5	—	nH	Between lead, 6mm (0.25in.)
$L_E$	Internal Emitter Inductance	—	7.5	—		from package and center of die contact

### Notes:

- ① Half sine wave with duty cycle = 0.05,  $t_{on} = 2\mu\text{sec}$ .
- ②  $R_\theta$  is measured at  $T_J$  of approximately  $90^\circ\text{C}$ .
- ③ Pulse width  $\leq 400\mu\text{s}$ ; duty cycle  $\leq 2\%$ .

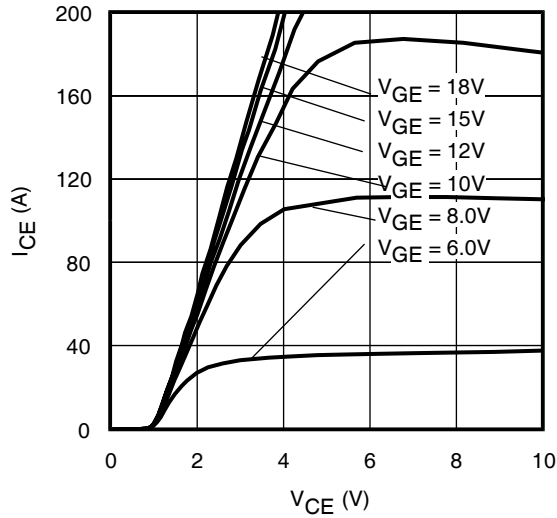

Fig 1. Typical Output Characteristics @ 25°C

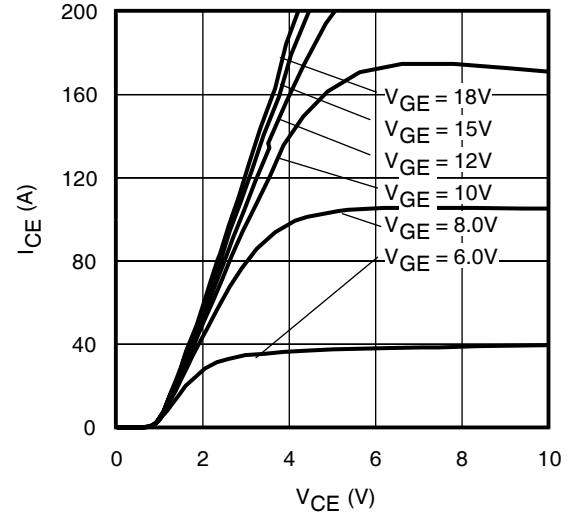

Fig 2. Typical Output Characteristics @ 75°C

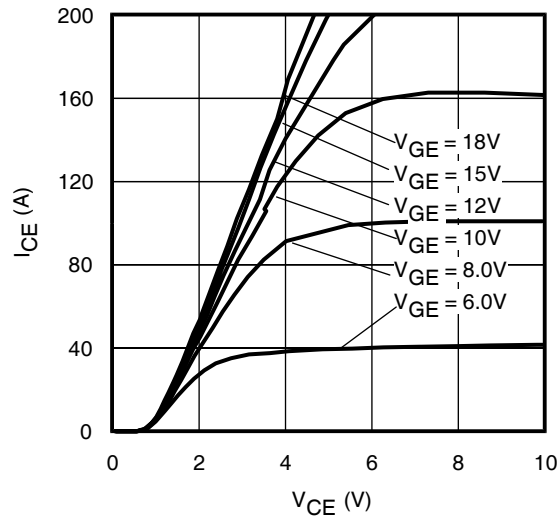

Fig 3. Typical Output Characteristics @ 125°C

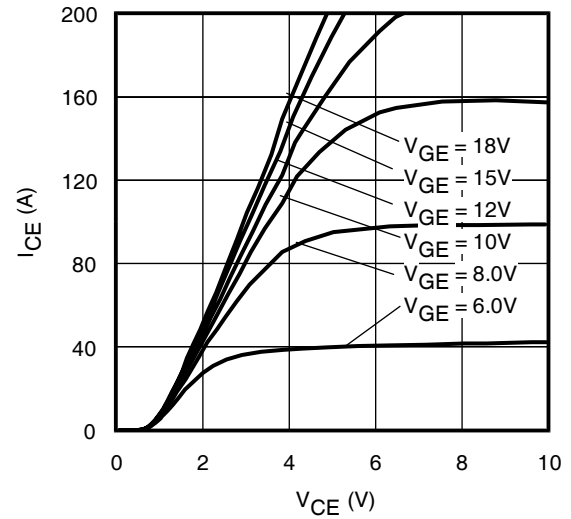

Fig 4. Typical Output Characteristics @ 150°C

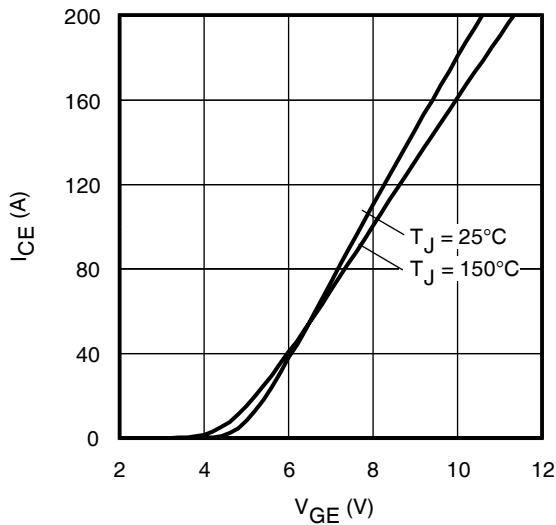

Fig 5. Typical Transfer Characteristics

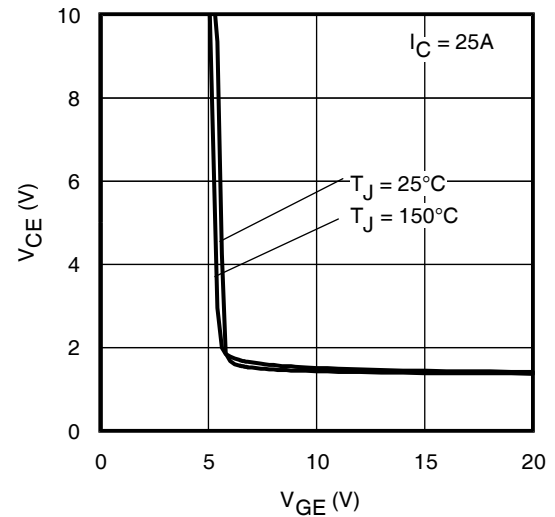

Fig 6.  $V_{CE(ON)}$  vs. Gate Voltage

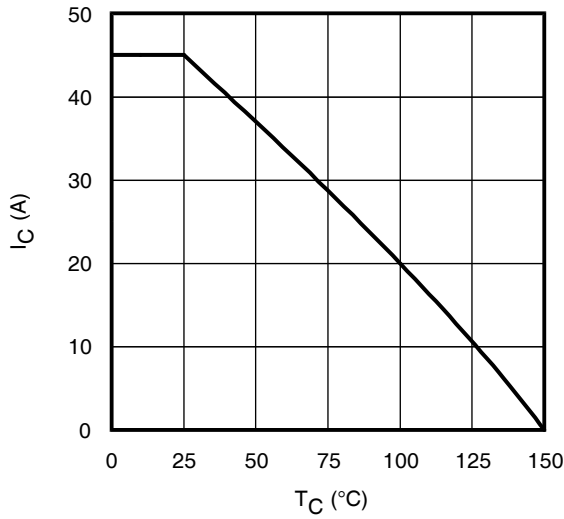

Fig 7. Maximum Collector Current vs. Case Temperature

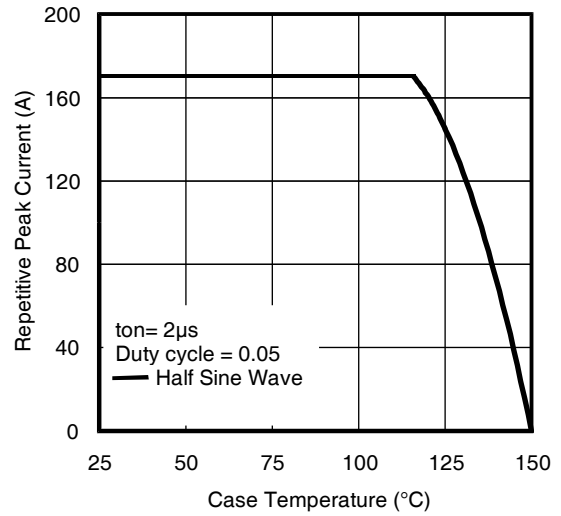

Fig 8. Typical Repetitive Peak Current vs. Case Temperature

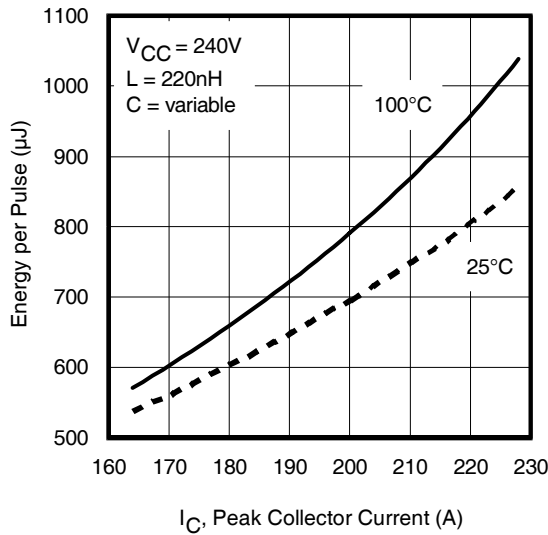

Fig 9. Typical  $E_{PULSE}$  vs. Collector Current

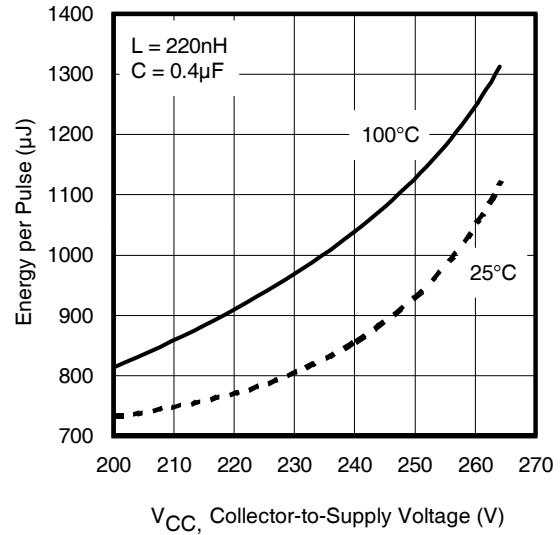

Fig 10. Typical  $E_{PULSE}$  vs. Collector-to-Supply Voltage

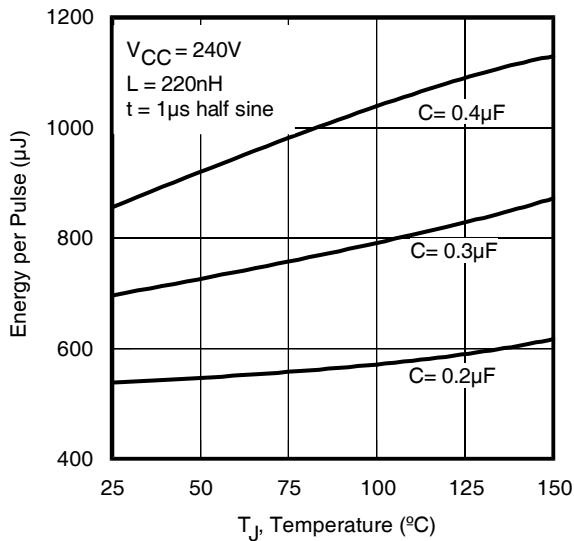

Fig 11.  $E_{PULSE}$  vs. Temperature

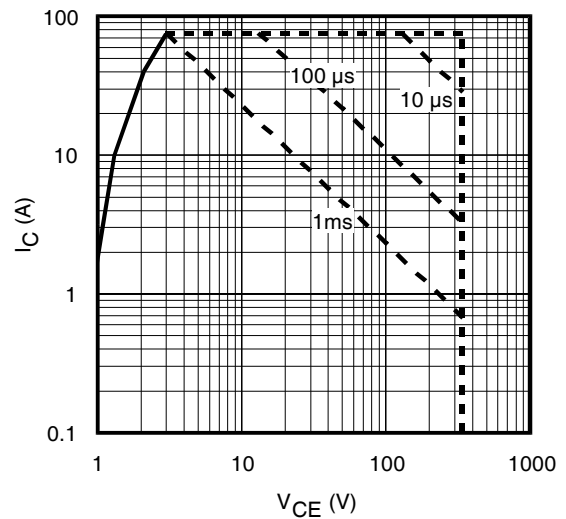

Fig 12. Forward Bias Safe Operating Area

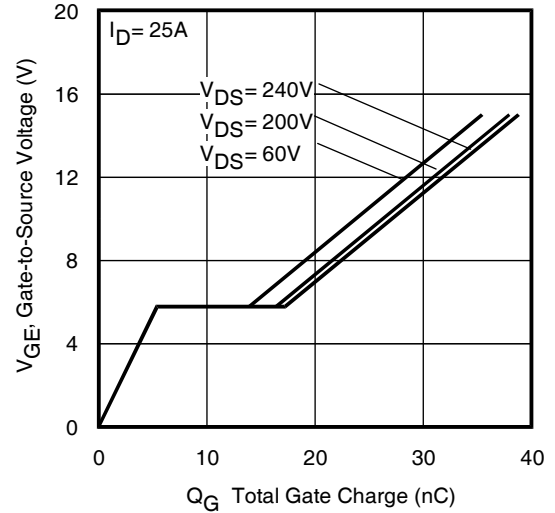
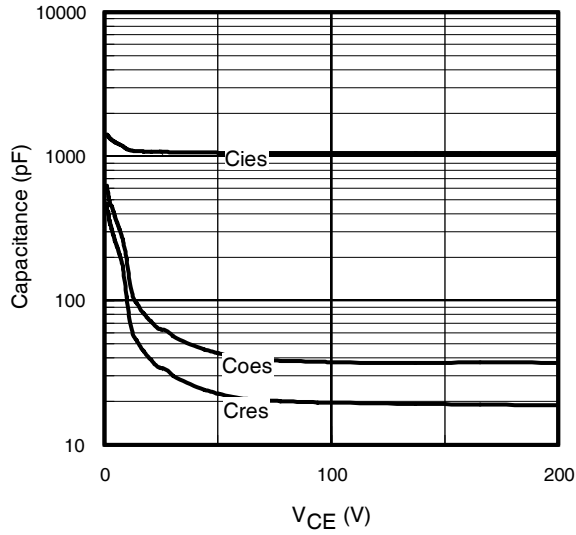

Fig 13. Typical Capacitance vs. Collector-to-Emitter Voltage

Fig 14. Typical Gate Charge vs. Gate-to-Emitter Voltage

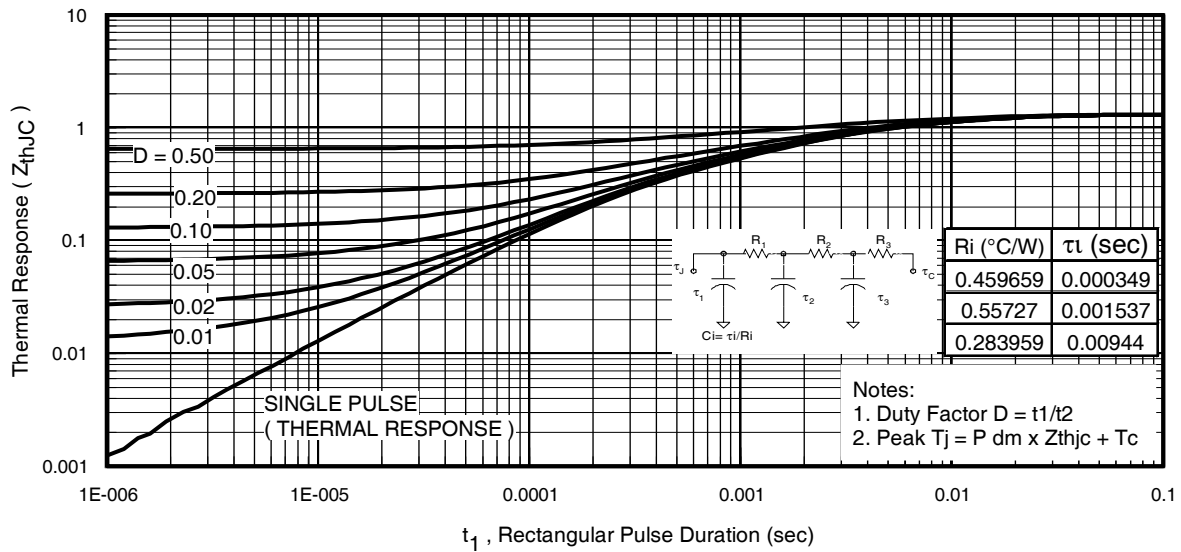
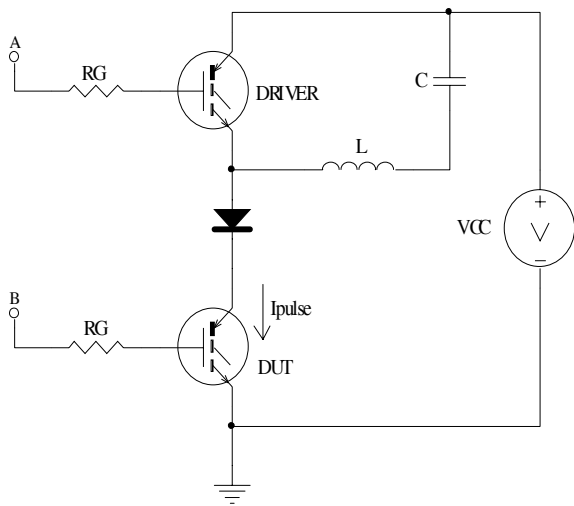
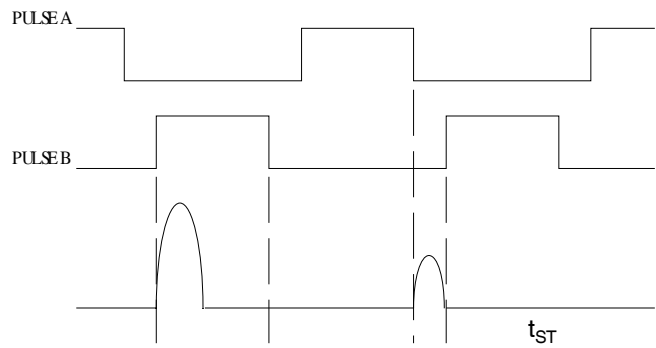

Fig 15. Maximum Effective Transient Thermal Impedance, Junction-to-Case



**Fig 16a.**  $t_{st}$  and  $E_{PULSE}$  Test Circuit



**Fig 16b.**  $t_{st}$  Test Waveforms

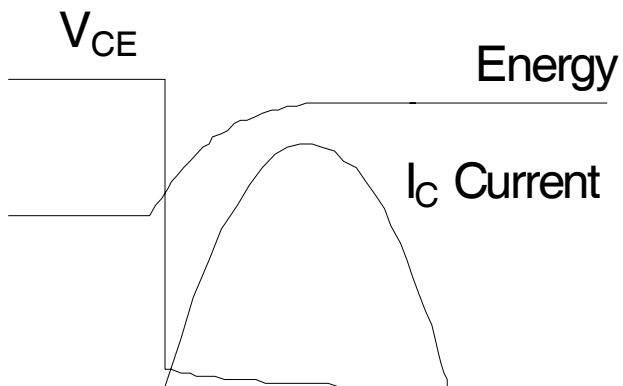

**Fig 16c.**  $E_{PULSE}$  Test Waveforms

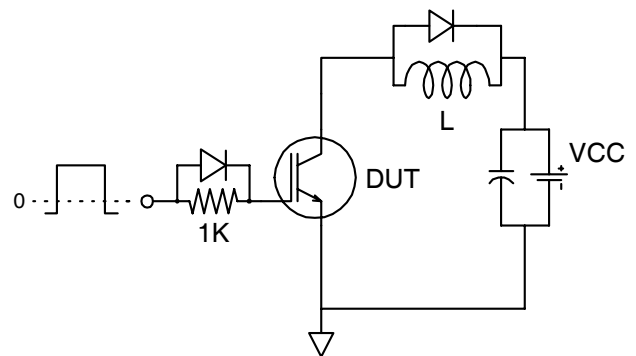

**Fig. 17 -** Gate Charge Circuit (turn-off)

## D<sup>2</sup>Pak (TO-263AB) Package Outline

Dimensions are shown in millimeters (inches)

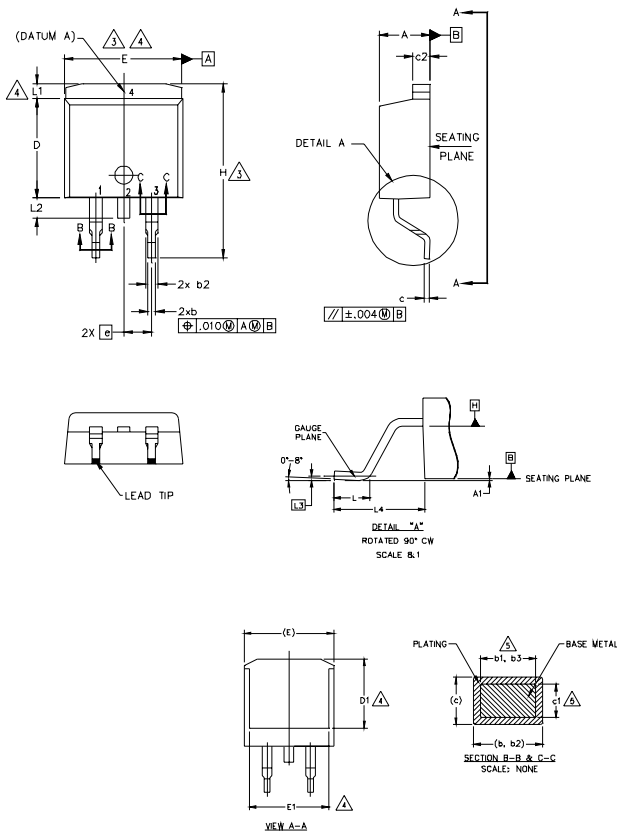

**NOTES:**

1. DIMENSIONING AND TOLERANCING PER ASME Y14.5M-1994
2. DIMENSIONS ARE SHOWN IN MILLIMETERS [INCHES].
3. DIMENSION D & E DO NOT INCLUDE MOLD FLASH. MOLD FLASH SHALL NOT EXCEED 0.127 [.005"] PER SIDE. THESE DIMENSIONS ARE MEASURED AT THE OUTMOST EXTREMES OF THE PLASTIC BODY AT DATUM H.
4. THERMAL PAD CONTOUR OPTIONAL WITHIN DIMENSION E, L1, D1 & E1.
5. DIMENSION b1 AND c1 APPLY TO BASE METAL ONLY.
6. DATUM A & B TO BE DETERMINED AT DATUM PLANE H.
7. CONTROLLING DIMENSION: INCH.
8. OUTLINE CONFORMS TO JEDEC OUTLINE TO-263AB.

SYMBOL	DIMENSIONS				NOTES
	MILLIMETERS		INCHES		
	MIN.	MAX.	MIN.	MAX.	
A	4.06	4.83	.160	.190	5
A1	0.00	0.254	.000	.010	
b	0.51	0.99	.020	.039	
b1	0.51	0.89	.020	.035	
b2	1.14	1.78	.045	.070	
b3	1.14	1.73	.045	.068	5
c	0.38	0.74	.015	.029	
c1	0.38	0.58	.015	.023	5
c2	1.14	1.65	.045	.065	
D	8.38	9.65	.330	.380	3
D1	6.86	-	.270	-	
E	9.65	10.67	.380	.420	3,4
E1	6.22	-	.245	-	
e	2.54 BSC		.100 BSC		4
H	14.61	15.88	.575	.625	
L	1.78	2.79	.070	.110	
L1	-	1.65	-	.066	
L2	1.27	1.78	-	.070	
L3	0.25 BSC		.010 BSC		4
L4	4.78	5.28	.188	.208	

**LEAD ASSIGNMENTS**

**HEXFET**

1. - GATE
- 2, 4. - DRAIN
3. - SOURCE

**IGBTs, CoPACK**

1. - GATE
- 2, 4. - COLLECTOR
3. - EMITTER

**DIODES**

1. - ANODE \*
- 2, 4. - CATHODE
3. - ANODE

\* PART DEPENDENT.

## D<sup>2</sup>Pak (TO-263AB) Part Marking Information

EXAMPLE: THIS IS AN IRF530S WITH  
LOT CODE 8024  
ASSEMBLED ON WW 02, 2000  
IN THE ASSEMBLY LINE "L"

Note: "P" in assembly line position  
indicates "Lead - Free"

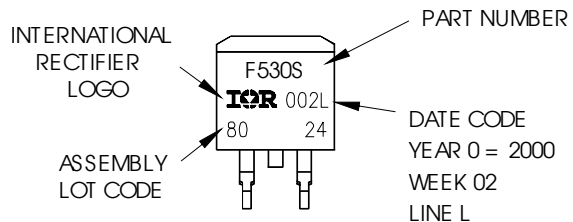

OR

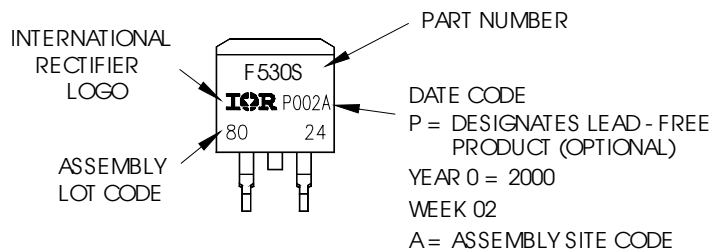

Note: For the most current drawing please refer to IR website at <http://www.irf.com/package/>

## D<sup>2</sup>Pak (TO-263AB) Tape & Reel Information

Dimensions are shown in millimeters (inches)

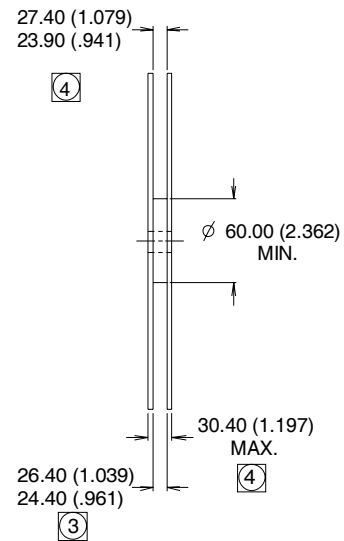
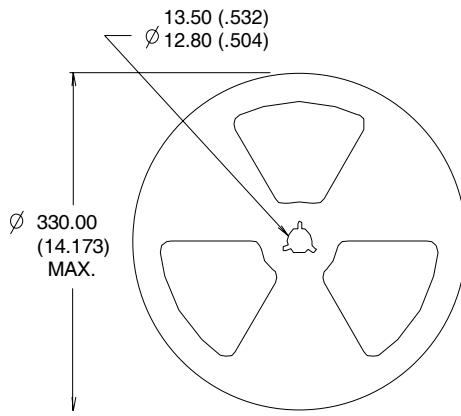
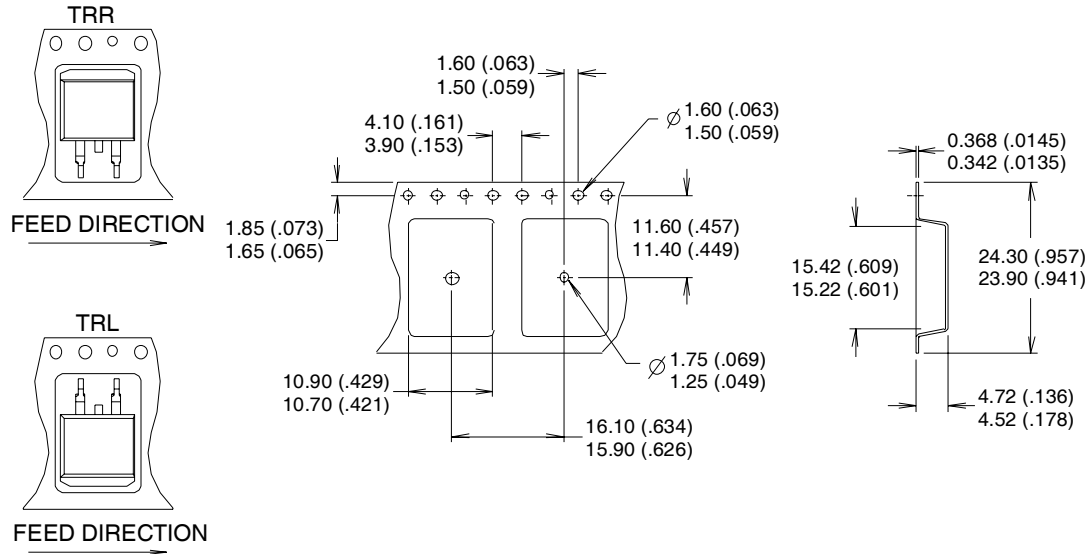

- NOTES :
1. CONFORMS TO EIA-418.
  2. CONTROLLING DIMENSION: MILLIMETER.
  - ③ DIMENSION MEASURED @ HUB.
  - ④ INCLUDES FLANGE DISTORTION @ OUTER EDGE.

Note: For the most current drawing please refer to IR website at <http://www.irf.com/package/>

Data and specifications subject to change without notice.  
This product has been designed for the Industrial market.  
Qualification Standards can be found on IR's Web site.