

2.5GBPS 850NM VCSEL LC TOSA PACKAGE

HFE419X-441

FEATURES:

- 850nm multi-mode oxide isolated VCSEL
- Extended Temperature Range Operation (- 40 to +85 deg operating range)
- Capable of modulation operation from DC to 2.5Gbps
- TO-46 tilt window metal can component, prealigned into LC Sleeve
- Designed for drive currents between 3-15mA average
- Packaged with a back monitor
- Attenuated window can

These products are high-performance 850nm VCSELs (Vertical Cavity Surface-Emitting Lasers) designed for high-speed data communications and packaged with a custom designed power monitor diode. The power monitor diode can be used with appropriate feedback control circuitry to set a maximum power level for the VCSEL. These combined features simplify design for high data rate communication and eye safety.

These products are high radiance VCSELs designed to convert electrical current into optical power that can be used in fiber optic communications and other applications. As the current varies above threshold, the light intensity increases proportionally.

These products are designed to be used with inexpensive silicon or gallium arsenide detectors, but excellent performance can also be achieved with some indium gallium arsenide detectors (see HFD3180-103 and HFD3180-108 product data sheets).

The low drive current requirement makes direct drive from PECL (Positive Emitter Coupled Logic) or ECL (Emitter Coupled Logic) gates possible and eases driver design.

VCSELs produce circularly symmetric, non-astigmatic, narrow divergence beams that, with appropriate lensing, fiber couple all of the emitter power. These LC TOSA products are pre-aligned and focused fiber optic transmitters designed to interface with 50/125 and 62.5/125 μm multi-mode fiber.



Part Number	Description
HFE4190-441	LC TOSA with attenuated TO-46 component, VCSEL with Back Monitor Photodiode, Anode of VCSEL common with Photodiode Cathode
HFE4191-441	LC TOSA with attenuated TO-46 component, VCSEL with Back Monitor Photodiode, Cathode of VCSEL common with Photodiode Anode

ABSOLUTE MAXIMUM RATINGS

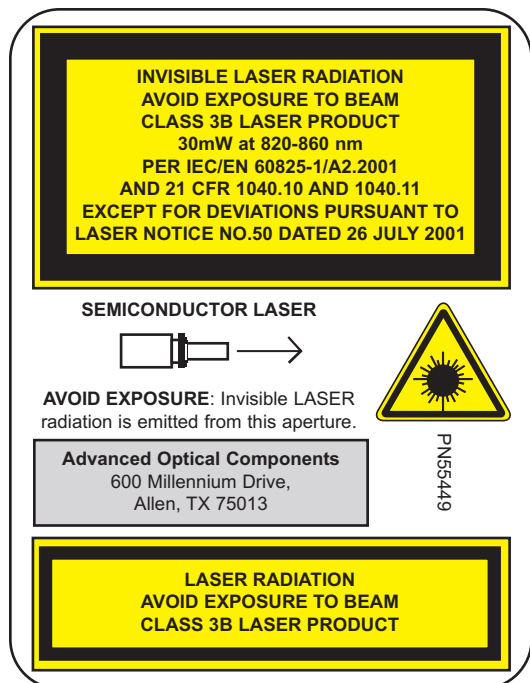

Parameter	Rating
Storage temperature	-40°C to +85°C
Operating temperature	-40°C to +85°C, See note 1 (page 3)
Lead solder temperature	260°C, 10 seconds
Laser continuous average current	12mA
Laser peak forward current with pulse width less than 1μs	18mA
Laser reverse voltage	5V

NOTICE: Stresses greater than those listed under “Absolute Maximum Ratings” may cause permanent damage to the device. This is a stress rating only and functional operation of the device at these or any other conditions above those indicated in the operations section for extended periods of time may affect reliability.

ELECTRICAL-OPTICAL CHARACTERISTICS

VCSEL Parameters	Test Condition	Symbol	Min.	Typ.	Max.	Units	Notes
Average Fiber Coupled Power	$I_F = 7\text{mA}$	P_{OC}		0.500		mW	2
Minimum coupling efficiency including wiggle	$I_F = 7\text{mA}$		55			%	2
Threshold Current		I_{TH}	0.5	1.8	2.5	mA	
Threshold Current maximum deviation from 25°C value	$T_A = 0^\circ\text{C to } 70^\circ\text{C}$	ΔI_{TH}	-0.5		1	mA	3
	$T_A = 25^\circ\text{C to } 85^\circ\text{C}$	ΔI_{TH}			1.7	mA	3
	$T_A = -40^\circ\text{C to } 25^\circ\text{C}$	ΔI_{TH}			2.5	mA	3
Temperature at minimum threshold current		T_O	-20		50	$^\circ\text{C}$	3
Slope Efficiency	$T_A = 25^\circ\text{C}$	η	0.04	0.125	0.16	mW/mA	4
	$T_A = -40^\circ\text{C}$	η			0.200	mW/mA	
	$T_A = 85^\circ\text{C}$	η	0.03			mW/mA	
Slope Efficiency Temperature variation	$T_A = 0^\circ\text{C to } 70^\circ\text{C}$	$\Delta\eta/\Delta T$		-6000		ppm/ $^\circ\text{C}$	5
Peak Wavelength	$I_F = 7\text{mA}$, $T_A = 0^\circ\text{C to } 85^\circ\text{C}$	λ_P	830	850	860	nm	
λ_P Temperature Variation	$I_F = 7\text{mA}$, $T_A = -40^\circ\text{C to } 85^\circ\text{C}$	$\Delta\lambda_P/\Delta T$		0.06		nm/ $^\circ\text{C}$	
Spectral Bandwidth, RMS	$I_F = 7\text{mA}$	$\Delta\lambda$			0.65	nm	
Laser Forward Voltage	$I_F = 7\text{mA}$	V_F		1.8	2.0	V	
Rise and Fall Times	$P_{avg} = 0.625\text{mW}$, Extinction Ratio = 10	t_r t_f			130 150	ps	6
Relative Intensity Noise	1 GHz BW, $I_F = 7\text{mA}$	RIN		-130	-122	dB/Hz	
Series Resistance	$I_F = 7\text{mA}$, $T_A = 25^\circ\text{C}$	R_S	25	35	50	Ω	
	$T_A = -40^\circ\text{C}$	R_S			60	Ω	
	$T_A = 85^\circ\text{C}$	R_S	20			Ω	
Series Resistance Temperature Coefficient	$I_F = 7\text{mA}$, $T_A = 0^\circ\text{C to } 70^\circ\text{C}$	$\Delta R_S/\Delta T$		-3000		ppm/ $^\circ\text{C}$	7
Photodiode Parameters	Test Condition	Symbol	Min.	Typ.	Max.	Units	Notes
Monitor Current	$P_{oc} = 0.5\text{mW}$, $T_A = 25^\circ\text{C}$	I_{PD}	0.1		0.6	mA	
	$P_{oc} = 0.5\text{mW}$, $T_A = -40^\circ\text{C}$	I_{PD}	TBD		TBD		
	$P_{oc} = 0.5\text{mW}$, $T_A = +85^\circ\text{C}$	I_{PD}	TBD		TBD	mA	
Monitor current Temperature Variation	$P_{oc} = 0.5\text{mW}$, $0^\circ\text{C to } 70^\circ\text{C}$	$\Delta I_{PD}/\Delta T$		TBD		%/ $^\circ\text{C}$	
Monitor Current Tracking		ΔI_{trk}		TBD			8
Dark Current	$P_o = 0\text{mW}$, $V_R = 3\text{V}$	I_D			20	nA	
PD Capacitance	$V_R = 0\text{V}$, Freq = 1MHz	C		75	100	pF	
	$V_R = 3\text{V}$, Freq = 1MHz			40	55		

NOTES

1. Reliability is a function of temperature, see www.finisar.com/aoc.php for details.
2. For the purpose of these tests, I_F is DC current.
3. Threshold current varies as $(T_A - T_O)^2$. It may either increase or decrease with temperature, depending upon relationship of T_A to T_O . The magnitude of the change is proportional to the threshold at T_O .
4. Slope efficiency is defined as $\Delta P_O / \Delta I_F$.
5. To compute the value of Slope Efficiency at a temperature T , use the following equation:

$$\eta(T) \approx \eta(25^\circ\text{C}) * [1 + (\Delta\eta/\Delta T) * (T - 25)]$$

6. Rise and fall times specifications are the 20% - 80%. Most of the devices will measure <135ps fall time. Rise and fall times are sensitive to drive electronics..
7. To compute the value of Series Resistance at a temperature T , use the following equation:

$$R_S(T) \approx R_S(25^\circ\text{C}) * [1 + \Delta R_S / \Delta T * (T - 25)]$$

8. Monitor current tracking is defined as follows:

$$\text{Deltrk} = \frac{I_{PD}(P_O = 0.75\text{mW}) / 0.75\text{mW}}{I_{PD}(P_O = 0.45\text{mW}) / 0.45\text{mW}}$$

TYPICAL PERFORMANCE CURVES

Emitted Power vs. Current: Power varies approximately linearly with current above threshold.

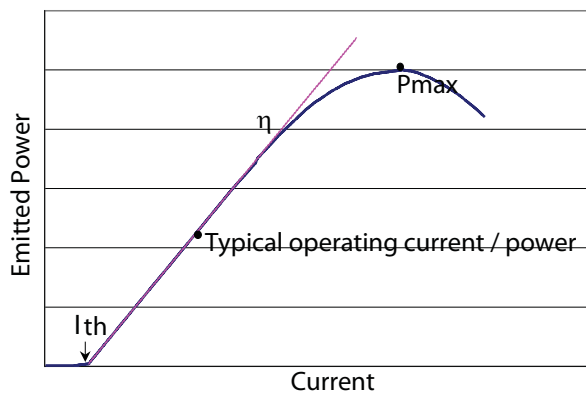

Threshold Current vs. Temperature: Threshold current varies parabolically with temperature; thus it can be nearly constant for a limited temperature range.

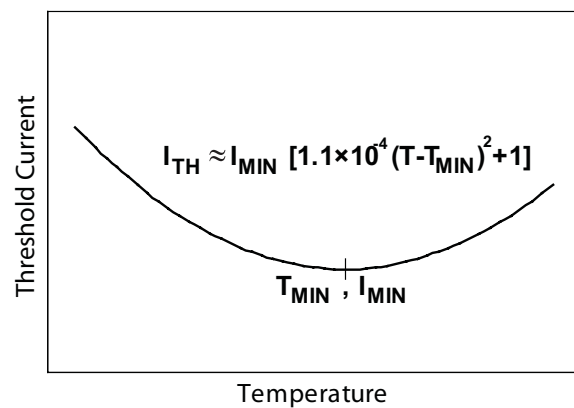

MOUNTING DIMENSIONS

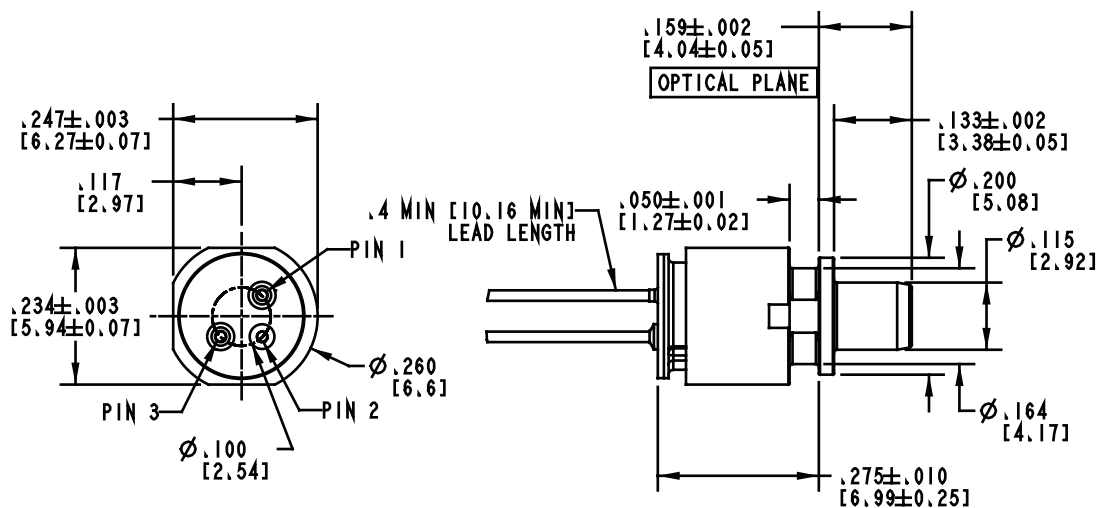

MOUNTING DIMENSIONS (for reference only): All dimensions are in inches.

PINOUT

HFE4190-441		HFE4191-441	
Number	Function	Number	Function
1	K _{LD}	1	A _{LD}
2	K _{PD} , A _{LD}	2	K _{LD} , A _{PD}
3	A _{PD}	3	K _{PD}

PINOUT DEFINITIONS

A _{LD}	VCSEL Anode	A _{PD}	Monitor Photodiode Anode
K _{LD}	VCSEL Cathode	K _{PD}	Monitor Photodiode Cathode

ADVANCED OPTICAL COMPONENTS

Finisar's ADVANCED OPTICAL COMPONENTS division was formed through strategic acquisition of key optical component suppliers. The company has led the industry in high volume Vertical Cavity Surface Emitting Laser (VCSEL) and associated detector technology since 1996. VCSELS have become the primary laser source for optical data communication, and are rapidly expanding into a wide variety of sensor applications. VCSELS' superior reliability, low drive current, high coupled power, narrow and circularly symmetric beam and versatile packaging options (including arrays) are enabling solutions not possible with other optical technologies. ADVANCED OPTICAL COMPONENTS is also a key supplier of Fabrey-Perot (FP) and Distributed Feedback (DFB) Lasers, and Optical Isolators (OI) for use in single mode fiber data and telecommunications networks

LOCATION

- Allen, TX - Business unit headquarters, VCSEL wafer growth, wafer fabrication and TO package assembly.
- Fremont, CA – Wafer growth and fabrication of 1310 to 1550nm FP and DFB lasers.
- Shanghai, PRC – Optical passives assembly, including optical isolators and splitters.

SALES AND SERVICE

Finisar's ADVANCED OPTICAL COMPONENTS division serves its customers through a worldwide network of sales offices and distributors. For application assistance, current specifications, pricing or name of the nearest Authorized Distributor, contact a nearby sales office or call the number listed below.

AOC CAPABILITIES

ADVANCED OPTICAL COMPONENTS' advanced capabilities include:

- 1, 2, 4, 8, and 10Gbps serial VCSEL solutions
- 1, 2, 4, 8, and 10Gbps serial SW DETECTOR solutions
- VCSEL and detector arrays
- 1, 2, 4, 8, and 10Gbps FP and DFB solutions at 1310 and 1550nm
- 1, 2, 4, 8, and 10Gbps serial LW DETECTOR solutions
- Optical Isolators from 1260 to 1600nm range
- Laser packaging in TO46, TO56, and Optical subassemblies with SC, LC, and MU interfaces for communication networks
- VCSELS operating at 670nm, 780nm, 980nm, and 1310nm in development
- Sensor packages include surface mount, various plastics, chip on board, chip scale packages, etc.
- Custom packaging options

Finisar

Advanced Optical Components Division

Phone: 1-866-MY-VCSEL USA (toll free)
1-214-509-2700 USA (Direct dial)
44 (0) 174 336 5533 Europe
886-935-409898 China & Taiwan
81-90-4437-1130 Japan
82-11-220-6153 Asia Pacific & Korea

Fax: 1-214-509-3709 USA

Email: support@adopco.com
WEB: www.finisar.com/aoc.php