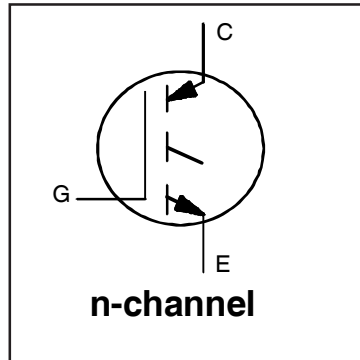


# IRG7SC12FPbF

## INSULATED GATE BIPOLAR TRANSISTOR

### Features

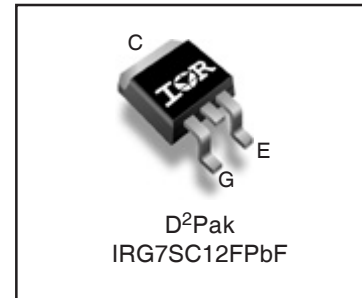
- Low  $V_{CE(ON)}$  Trench IGBT Technology
- Maximum Junction temperature 150 °C
- 3  $\mu$ S short circuit SOA
- Square RBSOA
- Positive  $V_{CE(ON)}$  Temperature co-efficient
- Tight parameter distribution
- Lead Free Package



$V_{CES} = 600V$
$I_C = 8A, T_C = 100^\circ C$
$t_{SC} \geq 3\mu s, T_{J(max)} = 150^\circ C$
$V_{CE(on)} \text{ typ.} = 1.60V$

### Benefits

- High Efficiency in a HVAC, Refrigerator applications
- Rugged transient Performance for increased reliability
- Excellent Current sharing in parallel operation
- Low EMI



<b>G</b>	<b>C</b>	<b>E</b>
Gate	Collector	Emitter

### Absolute Maximum Ratings

	Parameter	Max.	Units
$V_{CES}$	Collector-to-Emitter Voltage	600	V
$I_C @ T_C = 25^\circ C$	Continuous Collector Current	24	A
$I_C @ T_C = 100^\circ C$	Continuous Collector Current	13	
$I_{NOMINAL}$	Nominal Current	8	
$I_{CM}$	Pulse Collector Current	24	
$I_{LM}$	Clamped Inductive Load Current ①	32	
$V_{GE}$	Gate-to-Emitter Voltage	$\pm 30$	V
$P_D @ T_C = 25^\circ C$	Maximum Power Dissipation	69	W
$P_D @ T_C = 100^\circ C$	Maximum Power Dissipation	28	
$T_J$	Operating Junction and	-55 to +150	°C
$T_{STG}$	Storage Temperature Range		
	Soldering Temperature, for 10 sec.	300 (0.063 in. (1.6mm) from case)	

### Thermal Resistance

	Parameter	Min.	Typ.	Max.	Units
$R_{\theta JC}$	Thermal Resistance Junction-to-Case ②	—	—	1.8	°C/W
$R_{\theta CS}$	Thermal Resistance, Case-to-Sink (flat, greased surface)	—	0.50	—	
$R_{\theta JA}$	Thermal Resistance, Junction-to-Ambient (typical socket mount)	—	40	—	

### Electrical Characteristics @ $T_J = 25^\circ\text{C}$ (unless otherwise specified)

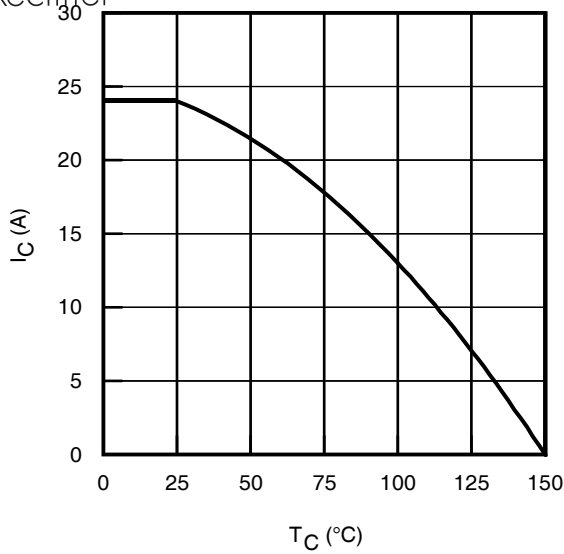
	Parameter	Min.	Typ.	Max.	Units	Conditions
$V_{(BR)CES}$	Collector-to-Emitter Breakdown Voltage	600	—	—	V	$V_{GE} = 0V, I_C = 250\mu A$
$\Delta V_{(BR)CES}/\Delta T_J$	Temperature Coeff. of Breakdown Voltage	—	0.58	—	V/ $^\circ\text{C}$	$V_{GE} = 0V, I_C = 1mA (25^\circ\text{C}-150^\circ\text{C})$
$V_{CE(on)}$	Collector-to-Emitter Saturation Voltage	—	1.60	1.85	V	$I_C = 8A, V_{GE} = 15V, T_J = 25^\circ\text{C} \text{ ②}$
		—	1.60	—		$I_C = 8A, V_{GE} = 15V, T_J = 150^\circ\text{C} \text{ ②}$
$V_{GE(th)}$	Gate Threshold Voltage	4.5	—	7.0	V	$V_{CE} = V_{GE}, I_C = 350\mu A$
$\Delta V_{GE(th)}/\Delta T_J$	Threshold Voltage temp. coefficient	—	-12	—	mV/ $^\circ\text{C}$	$V_{CE} = V_{GE}, I_C = 1.0mA (25^\circ\text{C} - 150^\circ\text{C})$
$g_{fe}$	Forward Transconductance	—	6.2	—	S	$V_{CE} = 50V, I_C = 8A, PW = 60\mu s$
$I_{CES}$	Collector-to-Emitter Leakage Current	—	1.0	20	$\mu A$	$V_{GE} = 0V, V_{CE} = 600V$
		—	80	—		$V_{GE} = 0V, V_{CE} = 600V, T_J = 150^\circ\text{C}$
$I_{GES}$	Gate-to-Emitter Leakage Current	—	—	$\pm 100$	nA	$V_{GE} = \pm 30V$

### Switching Characteristics @ $T_J = 25^\circ\text{C}$ (unless otherwise specified)

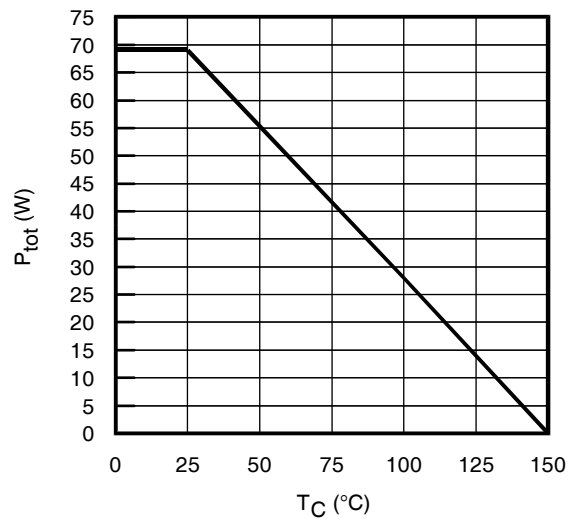
	Parameter	Min.	Typ.	Max.	Units	Conditions
$Q_g$	Total Gate Charge (turn-on)	—	34	51	nC	$I_C = 8A$ $V_{GE} = 15V$ $V_{CC} = 400V$
$Q_{ge}$	Gate-to-Emitter Charge (turn-on)	—	6.2	9.3		
$Q_{gc}$	Gate-to-Collector Charge (turn-on)	—	16	24		
$E_{on}$	Turn-On Switching Loss	—	390	610	$\mu J$	$I_C = 8A, V_{CC} = 400V, V_{GE} = 15V$ $R_G = 47\Omega, L = 1.0mH, L_S = 150nH$ $T_J = 25^\circ\text{C}$
$E_{off}$	Turn-Off Switching Loss	—	280	440		
$E_{total}$	Total Switching Loss	—	670	1050		
$t_{d(on)}$	Turn-On delay time	—	40	60	ns	$I_C = 8A, V_{CC} = 400V, V_{GE} = 15V$ $R_G = 47\Omega, L = 1.0mH, L_S = 150nH$ $T_J = 25^\circ\text{C}$
$t_r$	Rise time	—	20	40		
$t_{d(off)}$	Turn-Off delay time	—	210	270		
$t_f$	Fall time	—	120	180		
$E_{on}$	Turn-On Switching Loss	—	515	—	$\mu J$	$I_C = 8A, V_{CC} = 400V, V_{GE} = 15V$ $R_G = 47\Omega, L = 1.0mH, L_S = 150nH$ $T_J = 150^\circ\text{C}$
$E_{off}$	Turn-Off Switching Loss	—	570	—		
$E_{total}$	Total Switching Loss	—	1085	—		
$t_{d(on)}$	Turn-On delay time	—	30	—	ns	$I_C = 8A, V_{CC} = 400V, V_{GE} = 15V$ $R_G = 47\Omega, L = 1.0mH, L_S = 150nH$ $T_J = 150^\circ\text{C}$
$t_r$	Rise time	—	20	—		
$t_{d(off)}$	Turn-Off delay time	—	250	—		
$t_f$	Fall time	—	285	—		
$C_{ies}$	Input Capacitance	—	880	—	pF	$V_{GE} = 0V$ $V_{CC} = 30V$ $f = 1.0Mhz$
$C_{oes}$	Output Capacitance	—	30	—		
$C_{res}$	Reverse Transfer Capacitance	—	20	—		
RBSOA	Reverse Bias Safe Operating Area	FULL SQUARE				$T_J = 150^\circ\text{C}, I_C = 32A$ $V_{CC} = 480V, V_p \leq 600V$ $R_g = 47\Omega, V_{GE} = +20V \text{ to } 0V$
SCSOA	Short Circuit Safe Operating Area	3	—	—	$\mu s$	$V_{GE} = 15V, V_{CC} = 400V, V_p \leq 600V$ $R_g = 47\Omega, R_{shunt} = 33m\Omega, V_{GE} = +15V \text{ to } 0V$

#### Notes:

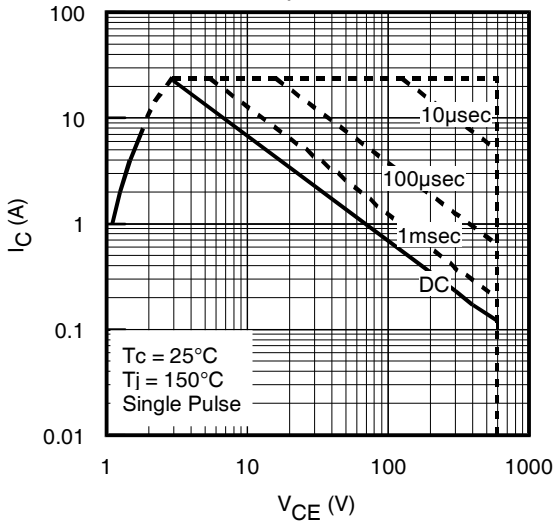
- ①  $V_{CC} = 80\% (V_{CES}), V_{GE} = 20V, L = 1.0mH, R_G = 47\Omega$ .
- ② Pulse width limited by max. junction temperature.
- ③  $R_\theta$  is measured at  $T_J$  of approximately  $90^\circ\text{C}$ .



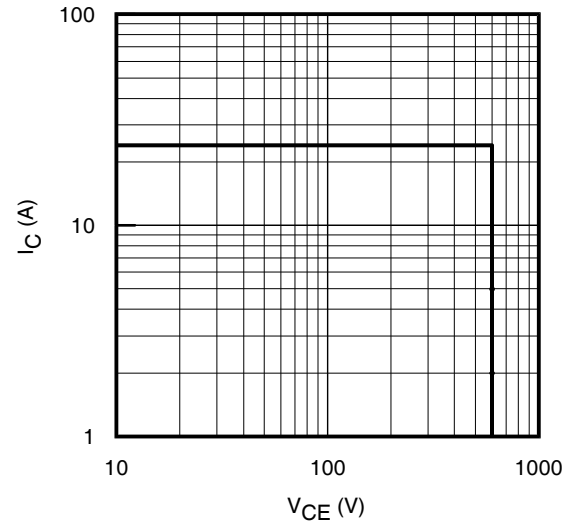
**Fig. 1 - Maximum DC Collector Current vs. Case Temperature**



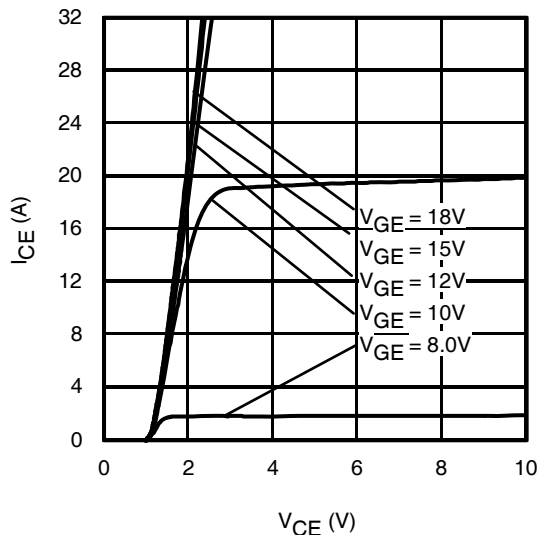
**Fig. 2 - Power Dissipation vs. Case Temperature**



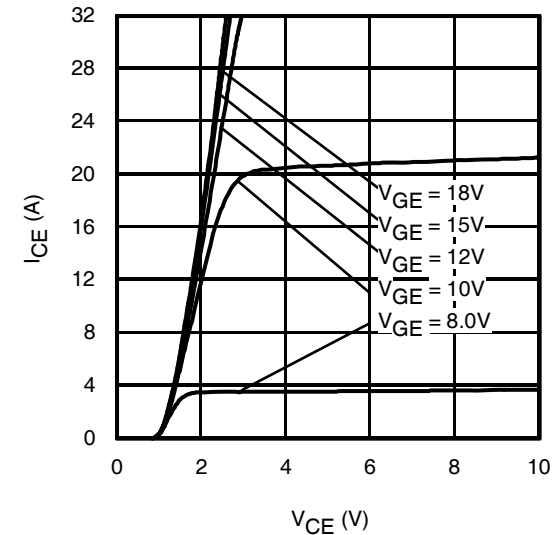
**Fig. 3 - Forward SOA**  
 $T_C = 25^\circ\text{C}$ ,  $T_J \leq 150^\circ\text{C}$ ;  $V_{GE} = 15\text{V}$



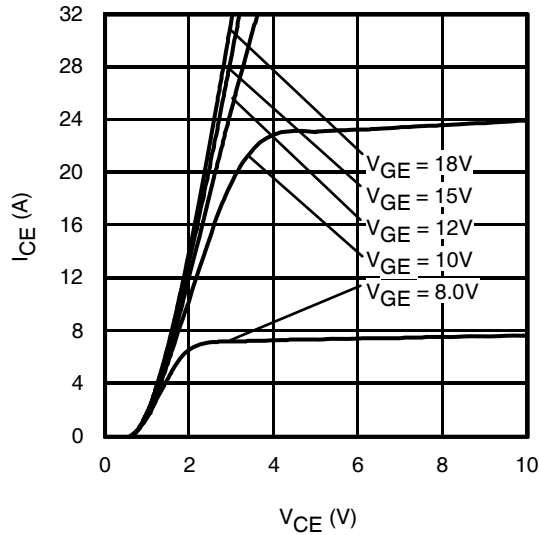
**Fig. 4 - Reverse Bias SOA**  
 $T_J = 150^\circ\text{C}$ ;  $V_{GE} = 15\text{V}$



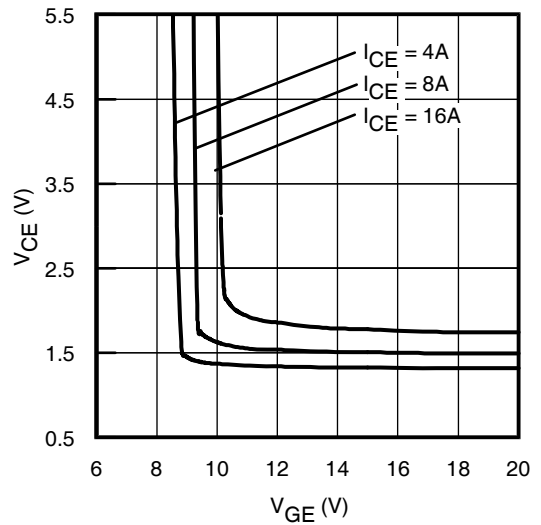
**Fig. 5 - Typ. IGBT Output Characteristics**  
 $T_J = -40^\circ\text{C}$ ;  $t_p = 60\mu\text{s}$



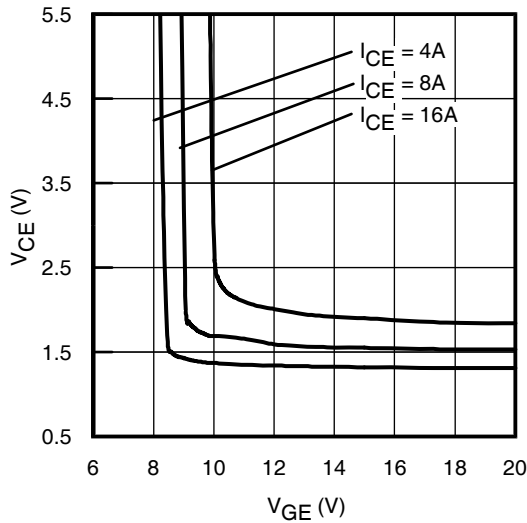
**Fig. 6 - Typ. IGBT Output Characteristics**  
 $T_J = 25^\circ\text{C}$ ;  $t_p = 60\mu\text{s}$



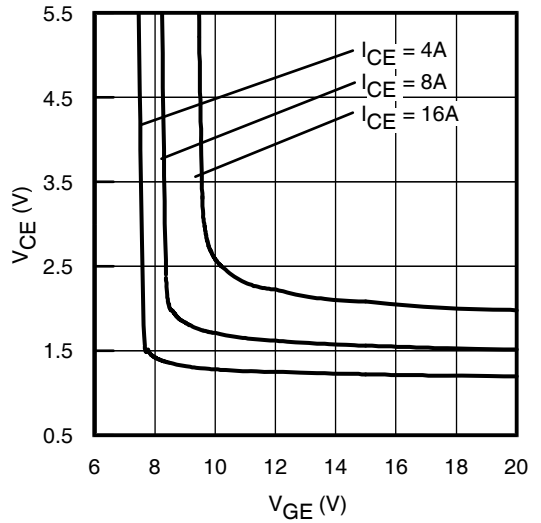
**Fig. 7 - Typ. IGBT Output Characteristics**  
 $T_J = 150^\circ\text{C}$ ;  $t_p = 60\mu\text{s}$



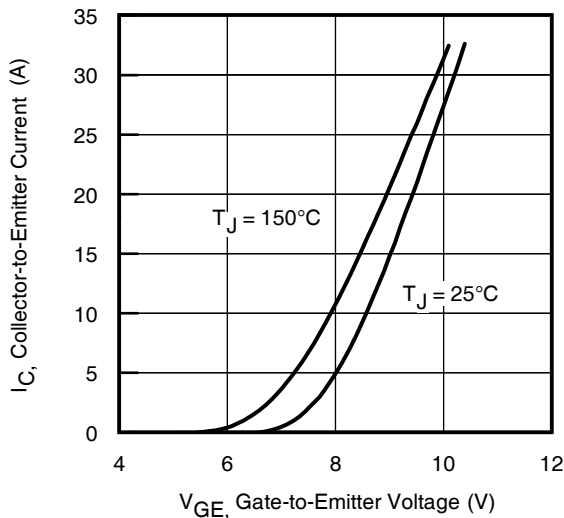
**Fig. 8 - Typical  $V_{CE}$  vs.  $V_{GE}$**   
 $T_J = -40^\circ\text{C}$



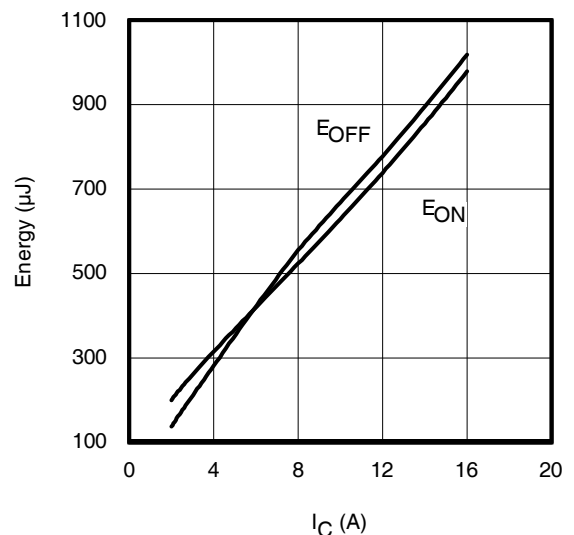
**Fig. 9 - Typical  $V_{CE}$  vs.  $V_{GE}$**   
 $T_J = 25^\circ\text{C}$



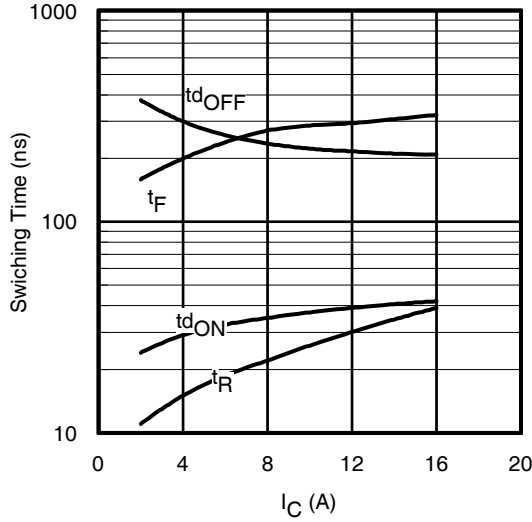
**Fig. 10 - Typical  $V_{CE}$  vs.  $V_{GE}$**   
 $T_J = 150^\circ\text{C}$



**Fig. 11 - Typ. Transfer Characteristics**  
 $V_{CE} = 50\text{V}$ ;  $t_p = 60\mu\text{s}$

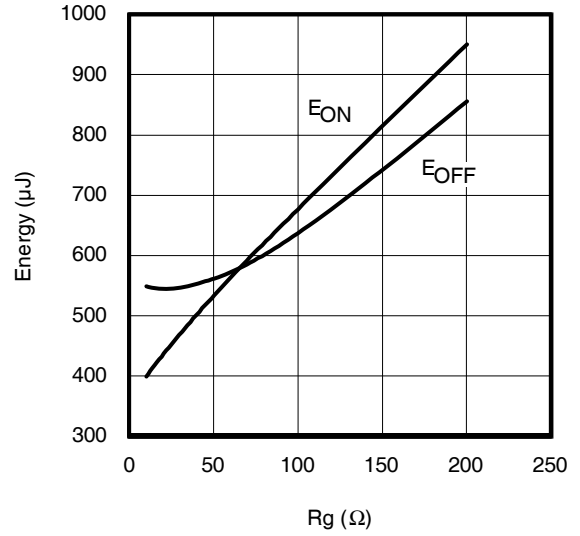


**Fig. 12 - Typ. Energy Loss vs.  $I_C$**   
 $T_J = 150^\circ\text{C}$ ;  $L = 1.0\text{mH}$ ;  $V_{CE} = 400\text{V}$ ,  $R_G = 47\Omega$ ;  $V_{GE} = 15\text{V}$



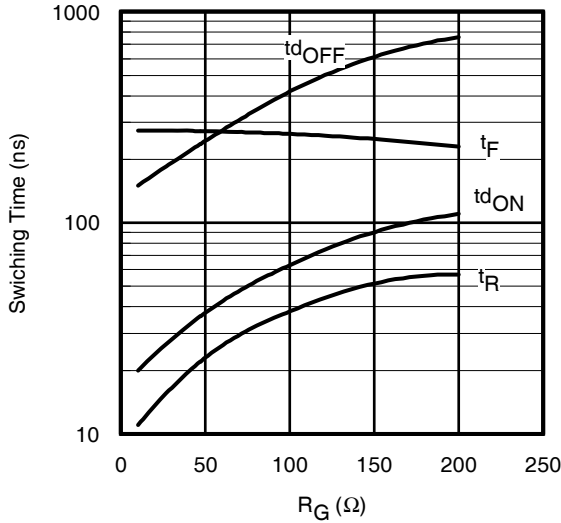
**Fig. 13** - Typ. Switching Time vs.  $I_C$

$T_J = 150^\circ\text{C}$ ;  $L = 1.0\text{mH}$ ;  $V_{CE} = 400\text{V}$ ,  $R_G = 47\Omega$ ;  $V_{GE} = 15\text{V}$



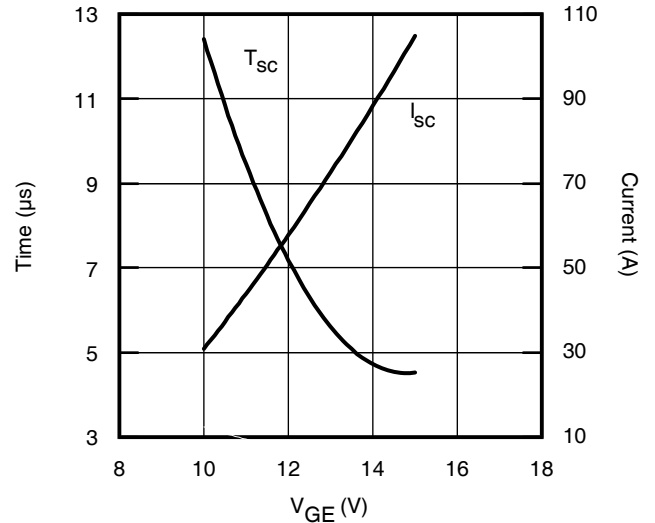
**Fig. 14** - Typ. Energy Loss vs.  $R_G$

$T_J = 150^\circ\text{C}$ ;  $L = 1.0\text{mH}$ ;  $V_{CE} = 400\text{V}$ ,  $I_{CE} = 8\text{A}$ ;  $V_{GE} = 15\text{V}$



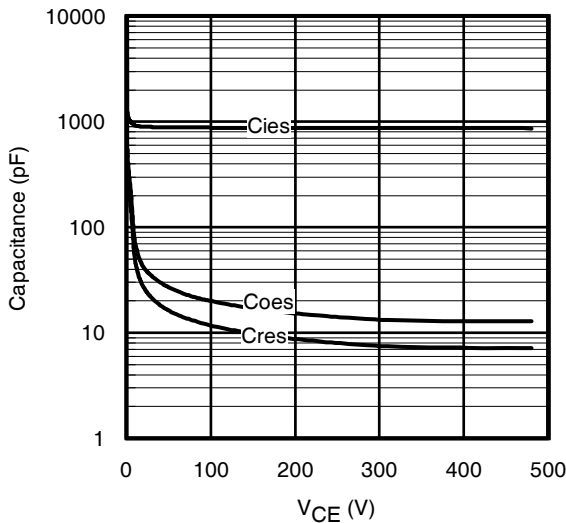
**Fig. 15** - Typ. Switching Time vs.  $R_G$

$T_J = 150^\circ\text{C}$ ;  $L = 1\text{mH}$ ;  $V_{CE} = 400\text{V}$ ,  $I_{CE} = 8\text{A}$ ;  $V_{GE} = 15\text{V}$



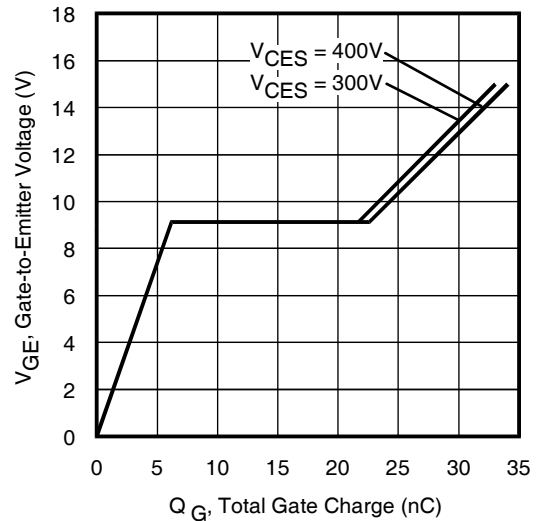
**Fig. 16** -  $V_{GE}$  vs. Short Circuit Time

$V_{CC} = 400\text{V}$ ;  $T_C = 25^\circ\text{C}$



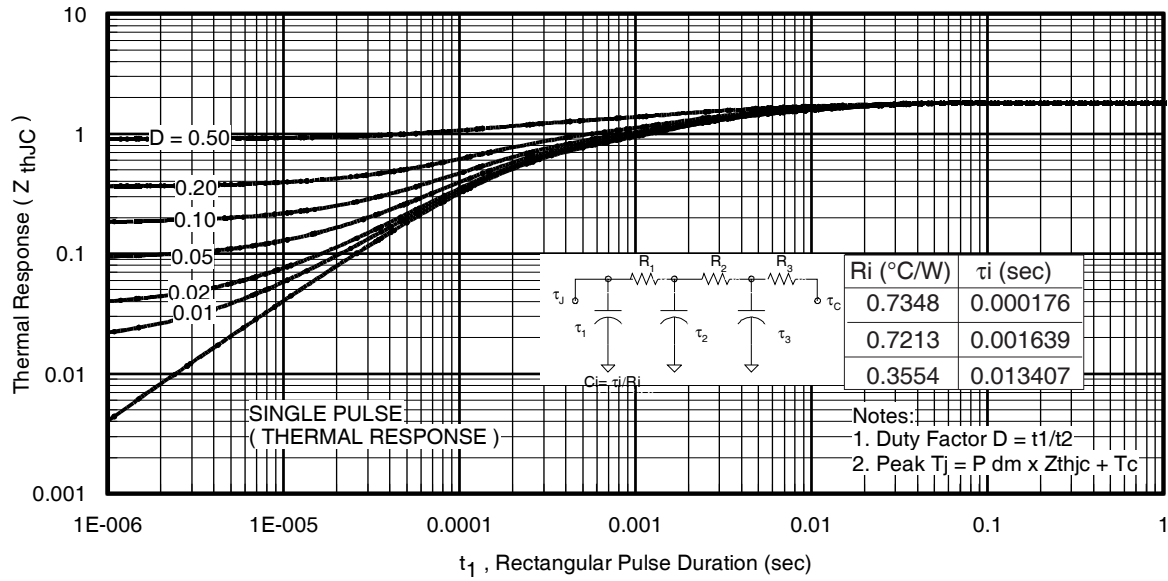
**Fig. 17** - Typ. Capacitance vs.  $V_{CE}$

$V_{GE} = 0\text{V}$ ;  $f = 1\text{MHz}$



**Fig. 18** - Typical Gate Charge vs.  $V_{GE}$

$I_{CE} = 8\text{A}$ ;  $L = 2.4\text{mH}$



**Fig 19.** Maximum Transient Thermal Impedance, Junction-to-Case (IGBT)

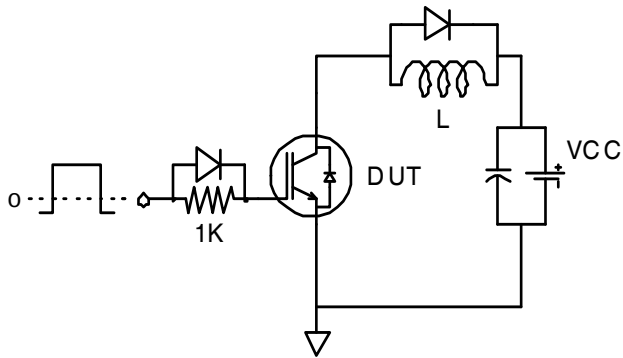


Fig.C.T.1 - Gate Charge Circuit (turn-off)

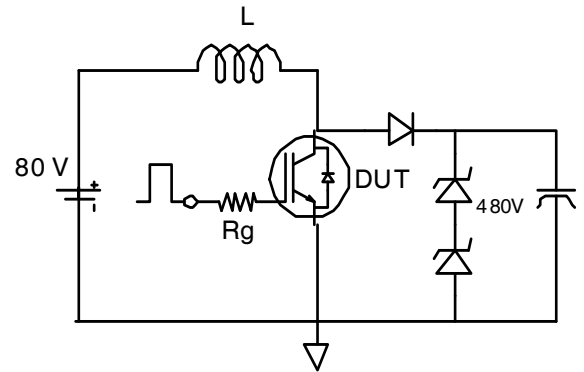


Fig.C.T.2 - RBSOA Circuit

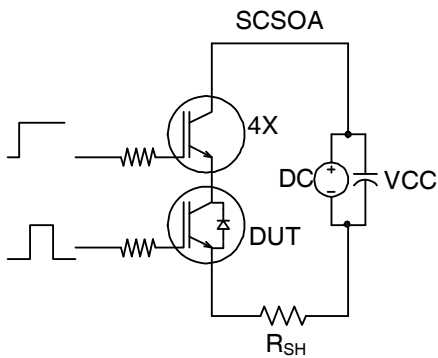


Fig.C.T.3 - S.C. SOA Circuit

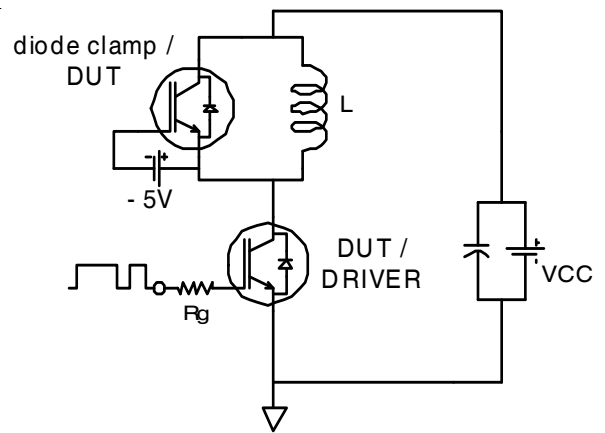


Fig.C.T.4 - Switching Loss Circuit

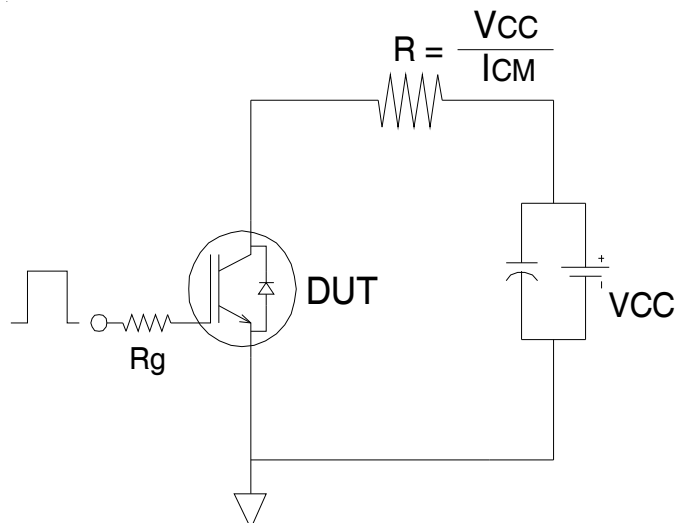
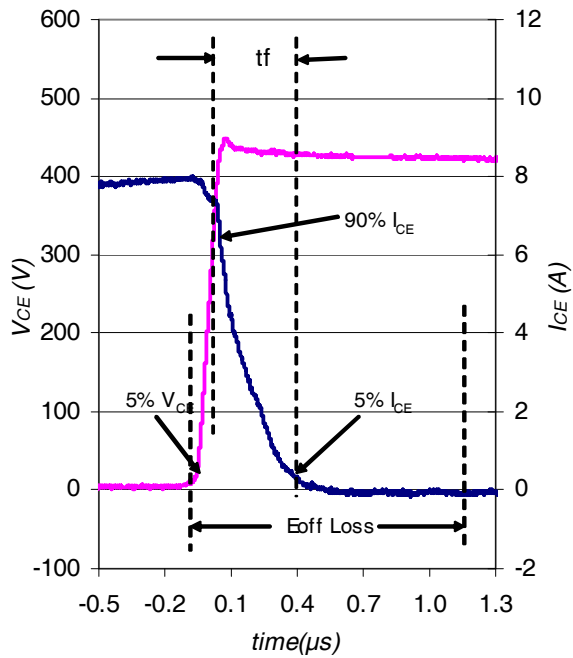
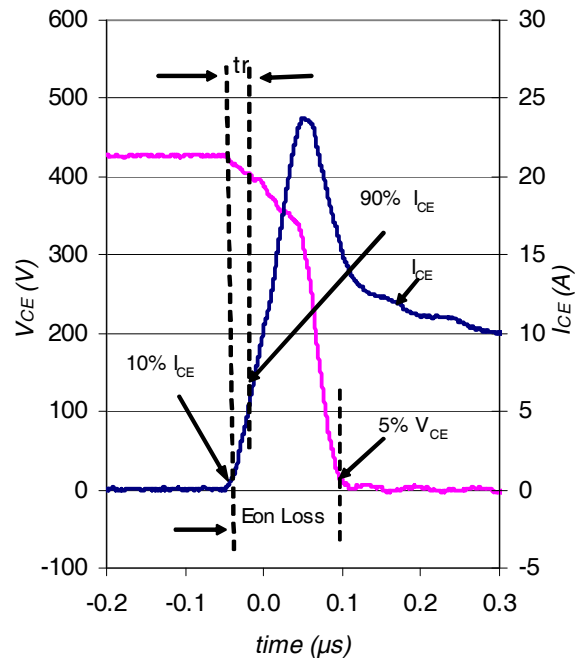


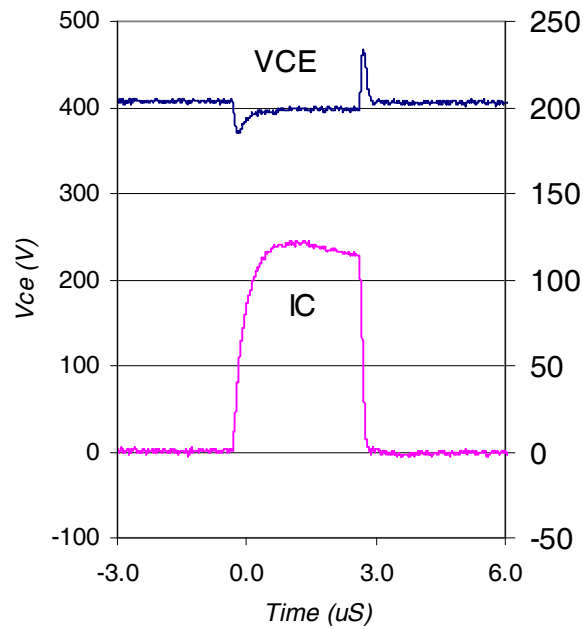
Fig.C.T.5 - Resistive Load Circuit



**Fig. WF1** - Typ. Turn-off Loss Waveform  
@  $T_J = 150^\circ C$  using Fig. CT.4



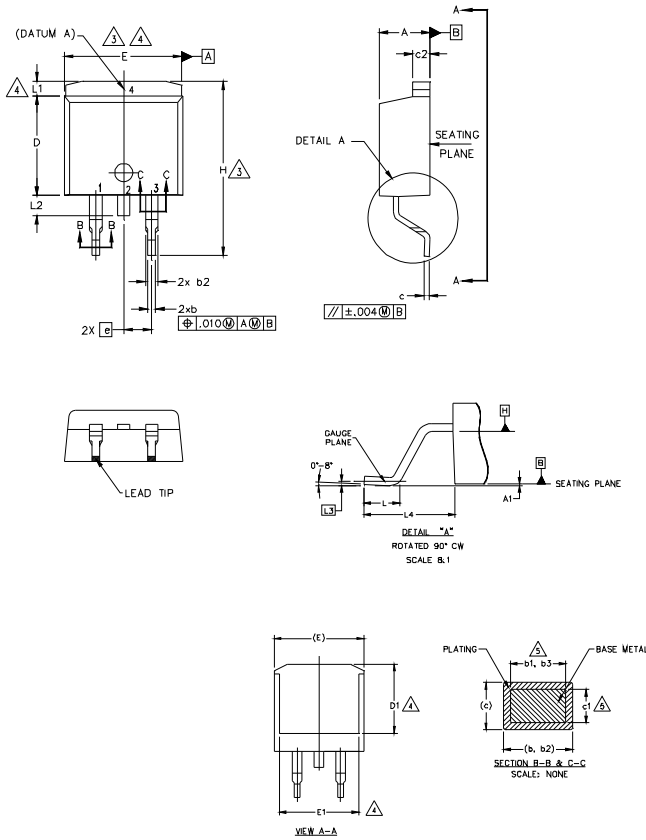
**Fig. WF2** - Typ. Turn-on Loss Waveform  
@  $T_J = 150^\circ C$  using Fig. CT.4



**Fig. WF3** - Typ. S.C. Waveform  
@  $T_J = 25^\circ C$  using Fig. CT.3

## D<sup>2</sup>Pak (TO-263AB) Package Outline

Dimensions are shown in millimeters (inches)



**NOTES:**

1. DIMENSIONING AND TOLERANCING PER ASME Y14.5M-1994
2. DIMENSIONS ARE SHOWN IN MILLIMETERS [INCHES].
3. DIMENSION D & E DO NOT INCLUDE MOLD FLASH. MOLD FLASH SHALL NOT EXCEED 0.127 [0.005"] PER SIDE. THESE DIMENSIONS ARE MEASURED AT THE OUTMOST EXTREMES OF THE PLASTIC BODY AT DATUM H.
4. THERMAL PAD CONTOUR OPTIONAL WITHIN DIMENSION E, L1, D1 & E1.
5. DIMENSION b1 AND c1 APPLY TO BASE METAL ONLY.
6. DATUM A & B TO BE DETERMINED AT DATUM PLANE H.
7. CONTROLLING DIMENSION: INCH.
8. OUTLINE CONFORMS TO JEDEC OUTLINE TO-263AB.

SYMBOL	DIMENSIONS				NOTES
	MILLIMETERS		INCHES		
	MIN.	MAX.	MIN.	MAX.	
A	4.06	4.83	.160	.190	5
A1	0.00	0.254	.000	.010	
b	0.51	0.99	.020	.039	
b1	0.51	0.89	.020	.035	5
b2	1.14	1.78	.045	.070	
b3	1.14	1.73	.045	.068	5
c	0.38	0.74	.015	.029	
c1	0.38	0.58	.015	.023	5
c2	1.14	1.65	.045	.065	
D	8.38	9.65	.330	.380	3
D1	6.86	-	.270	-	
E	9.65	10.67	.380	.420	3,4
E1	6.22	-	.245	-	
e	2.54 BSC		.100 BSC		4
H	14.61	15.88	.575	.625	
L	1.78	2.79	.070	.110	
L1	-	1.65	-	.066	
L2	1.27	1.78	-	.070	
L3	0.25 BSC		.010 BSC		
L4	4.78	5.28	.188	.208	

**LEAD ASSIGNMENTS**

**HEXFET**

- 1.- GATE
- 2, 4.- DRAIN
- 3.- SOURCE

**IGBTs, CoPACK**

- 1.- GATE
- 2, 4.- COLLECTOR
- 3.- EMITTER

**DIODES**

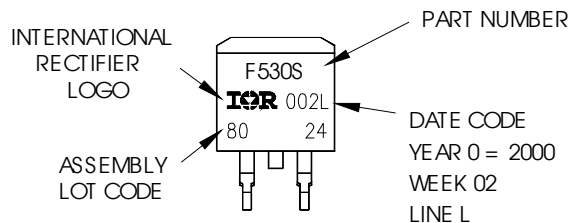
- 1.- ANODE \*
- 2, 4.- CATHODE
- 3.- ANODE

\* PART DEPENDENT.

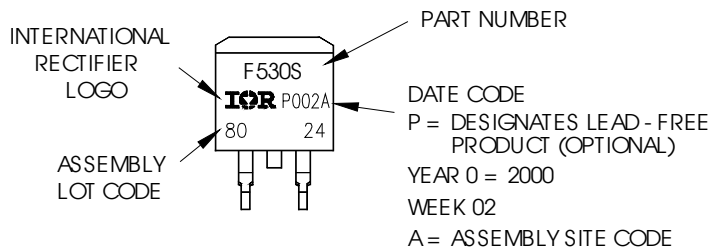
## D<sup>2</sup>Pak (TO-263AB) Part Marking Information

EXAMPLE: THIS IS AN IRF530S WITH  
LOT CODE 8024  
ASSEMBLED ON WW 02, 2000  
IN THE ASSEMBLY LINE "L"

Note: "P" in assembly line position  
indicates "Lead - Free"



OR

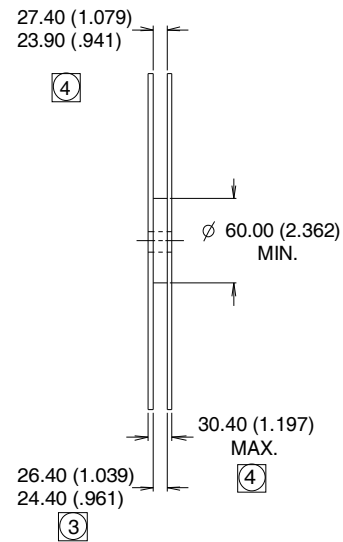
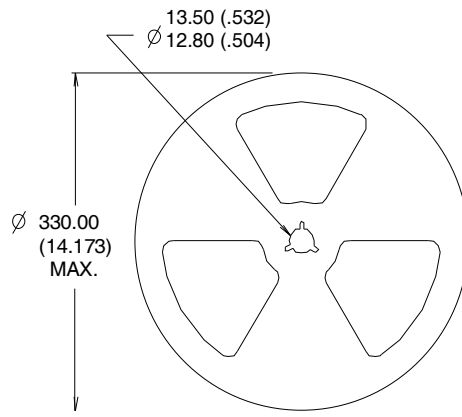
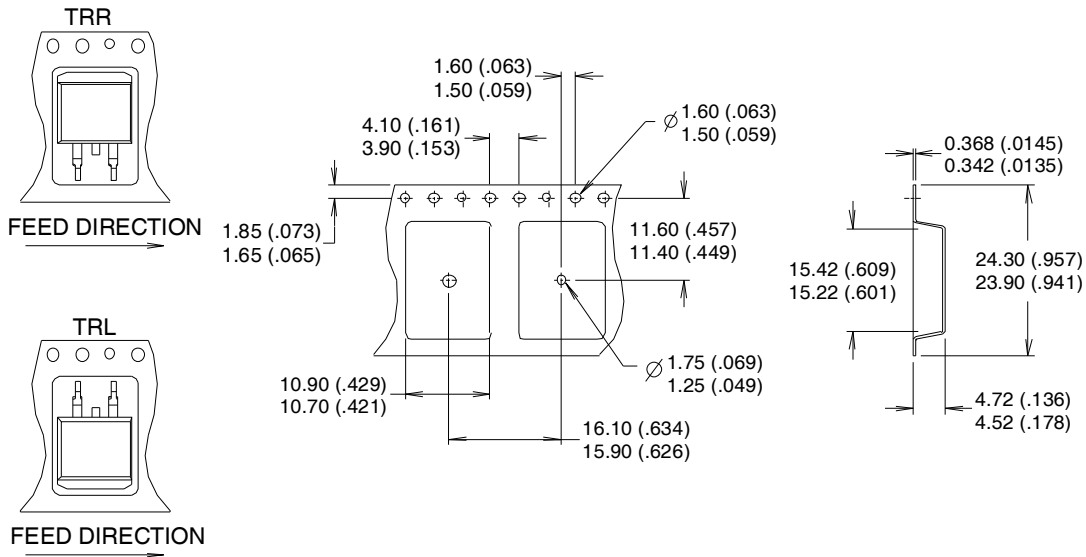


Note: For the most current drawing please refer to IR website at <http://www.irf.com/package/pkhexfet.html>

# IRG7SC12FPbF

## D<sup>2</sup>Pak (TO-263AB) Tape & Reel Information

Dimensions are shown in millimeters (inches)



**NOTES :**

1. COMFORMS TO EIA-418.
2. CONTROLLING DIMENSION: MILLIMETER.
- ③ DIMENSION MEASURED @ HUB.
- ④ INCLUDES FLANGE DISTORTION @ OUTER EDGE.

**Note:** For the most current drawing please refer to IR website at <http://www.irf.com/package/pkhexfet.html>

Data and specifications subject to change without notice.  
This product has been designed and qualified for Industrial market.  
Qualification Standards can be found on IR's Web site.