

5GBPS 850NM VCSEL ARRAYS

V850-2092-001, V850-2093-001

FEATURES:

- *Stabilized* and fully tested
- Designed for drive currents between 3 and 7 mA average
- Optimized for low dependence of electrical properties over temperature
- High speed ≥ 6 GHz



The V850-209x-001 are high-performance 850 nm VCSEL (Vertical Cavity Surface-Emitting Laser) die arrays optimized for high-speed data communications.

The array die are fully *stabilized* and tested, ideal for use in manufacturing transceivers for parallel optical interconnects. The arrays are available in 4 or 12 channel configurations.

Each device is a high radiance VCSEL designed to convert electrical current into optical power that can be used in fiber optic communications and other applications. As the current varies above threshold, the light intensity increases proportionally.

The V850-209x-001 are designed to be used with inexpensive silicon or gallium arsenide detectors, but excellent performance can also be achieved with some indium gallium arsenide detectors.

The low drive current requirement makes direct drive from PECL (Positive Emitter Coupled Logic) or ECL (Emitter Coupled Logic) gates possible and eases driver design.

Designed to interface with 50/125 and 62.5/125 μ m multimode fiber, the VCSELs produce circularly symmetric, non-astigmatic, narrow divergence beams that, with appropriate lensing, fiber couple all of the emitter power.

The top (anode) contact is a minimum 1 μ m thick Au pad for ease of wire bonding. Wire bonding should be done with minimal pressure to ensure the VCSEL is not damaged. The backside common VCSEL cathode is also a minimum thickness 1 μ m Au metallurgy. The die must be mounted using thermally and electrical conductive media.

The VCSEL arrays are shipped on medium tack blue tape in 6 inch grip rings.

Part Number	Description
V850-2092-001	5Gbps 4 channel VCSEL die array
V850-2093-001	5Gbps 12 channel VCSEL die array

ABSOLUTE MAXIMUM RATINGS

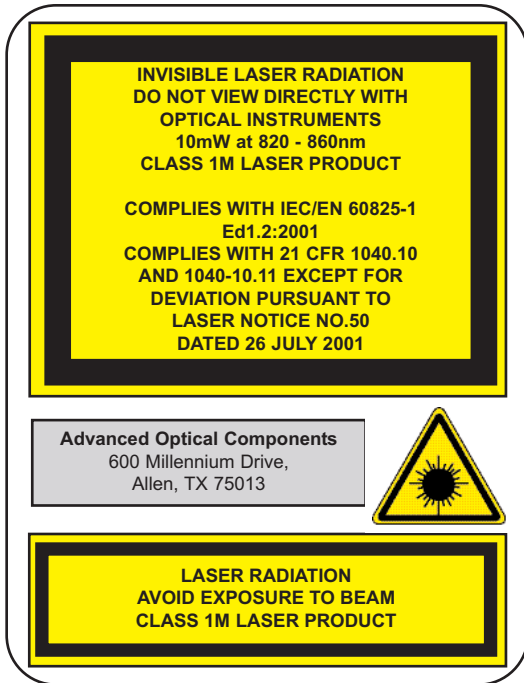

Parameter	Rating
Storage temperature	-40°C to +100°C
Operating temperature	0 to +70°C, see note 1
Laser continuous forward current	10mA
Laser peak forward current with pulse width less than 1μs	12mA
Laser reverse voltage	5V

NOTICE: Stresses greater than those listed under “Absolute Maximum Ratings” may cause permanent damage to the device. This is a stress rating only and functional operation of the device at these or any other conditions above those indicated in the operations section for extended periods of time may affect reliability.

ELECTRICAL-OPTICAL CHARACTERISTICS

 $T_A = 25^\circ\text{C}$ unless otherwise stated

VCSEL Parameters	Test Condition	Symbol	Min.	Typ.	Max.	Uniformity	Units	Notes
Optical Output Power	$I_F = 6.5\text{mA}$	P_O	1.4	2.0		15%	mW	2
Threshold Current		I_{TH}	0.5	1	1.75	0.2	mA	
Threshold Current maximum deviation from 25°C value	$T_A = 0$ to 70°C	ΔI_{TH}	-0.5		0.8	0.2	mA	3
	$T_A = 25$ to 85°C				1.5			
	$T_A = -40$ to 25°C				0.75			
Temperature at minimum threshold current		T_0	-20		50		$^\circ\text{C}$	3
Slope Efficiency	$T_A = 25^\circ\text{C}$	η	0.3	0.4	0.6	0.05	mW/mA	4
	$T_A = -40^\circ\text{C}$				0.75			
	$T_A = 85^\circ\text{C}$		0.19					
Slope Efficiency Temperature Variation	$T_A = 0$ to 70°C	$\Delta\eta/\Delta T$	-3000	-7000	-10000		ppm/ $^\circ\text{C}$	5
Peak Wavelength	$I_F = 6\text{mA}$ $T_A = 0$ to 70°C	λ_p	840	850	860	1	nm	
λ_p Temperature Variation	$I_F = 6\text{mA}$ $T_A = 0$ to 70°C	$\Delta\lambda_p/\Delta T$		0.06			nm/ $^\circ\text{C}$	
RMS Spectral Bandwidth	$I_F = 6\text{mA}$	$\Delta\lambda$			0.85		nm	
Laser Forward Voltage	$I_F = 6\text{mA}$	V_F		1.8	2.1	0.1	V	
Roll over		P_{max}	3.0				mW	6
Rise/Fall Time	$P_{avg} = 2\text{mW}$, Extinction Ratio = 5dB	T_R T_F			80 80		ps	7
Deterministic Jitter	$I_F = 6\text{mA}$, Extinction Ratio = 5dB	DJ			40		ps	7
Relative Intensity Noise	10GHz BW, $I_F = 6\text{mA}$	RIN		-135	-130		dB/Hz	
Series Resistance	$I_F = 6\text{mA}$, $T_A = 25^\circ\text{C}$	R_S	40	50	60	3	Ohms	
	$T_A = -40^\circ\text{C}$				75			
	$T_A = 85^\circ\text{C}$		30					
Series Resistance Temperature Coefficient	$I_F = 6\text{mA}$, $T_A = 0$ to 70°C	$\Delta R_S/\Delta T$		-3000			ppm/ $^\circ\text{C}$	8
Total Capacitance	$I_F = 6\text{mA}$, $F = 1\text{MHz}$	C_T			0.25	10%	pF	6
Beam Divergence		Θ	15		30	10%	Degree	9
Beam Divergence current variation		$\Delta\Theta/\Delta I_F$		0.6		10%	Degree/ mA	

Uniformity is the difference between the maximum and the minimum measured value across the array.

Maximum and Minimum are defined per array.

NOTES

1. Reliability is a function of temperature, see www.finisar.com/aoc.php for details.
2. For the purpose of these tests, I_F is DC current.
3. Threshold current varies as $(T_A - T_0)^2$. It may either increase or decrease with temperature, depending upon relationship of T_A to T_0 . The magnitude of the change is proportional to the threshold at T_0 .
4. Slope efficiency is defined as $\Delta P_O / \Delta I_F$.
5. To compute the value of Slope Efficiency at a temperature T, use the following equation:

$$\eta(T) \approx \eta(25^\circ\text{C}) * [1 + (\Delta\eta / \Delta T) * (T - 25)]$$
6. Rollover is the power at which a further current increase does not result in a power increase.
7. Rise and fall times specifications are the 20% - 80%. DJ is measured using a reconstructed eye diagram of an averaged optical waveform. Rise/Fall times and DJ measurements are made at 4.25Gbps using a k28.7 and k28.5 Fibre Channel pattern respectively. The electrical driving waveform is provided by a 10Gbps pattern generator through a bias tee.
8. To compute the value of Series Resistance at a temperature T, use the following equation:

$$R_S(T) \approx R_S(25^\circ\text{C}) * [1 + \Delta R_S / \Delta T] * (T - 25)$$
9. Beam divergence is defined as the total included angle between the $1/e^2$ intensity points.
10. The reliability of a 12 element array is $1/2$ that of the singlet reliability. The reliability of a 4 element array is $2/3$ that of a singlet.

TYPICAL PERFORMANCE CURVES

Emitted Power vs. Current: Power varies approximately linearly with current above threshold.

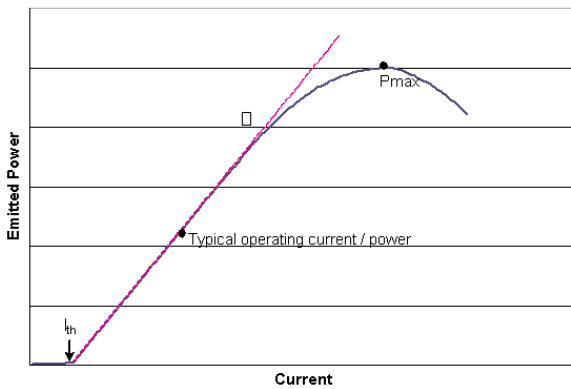

Threshold Current vs. Temperature: Threshold current varies parabolically with temperature; thus it can be nearly constant for a limited temperature range.

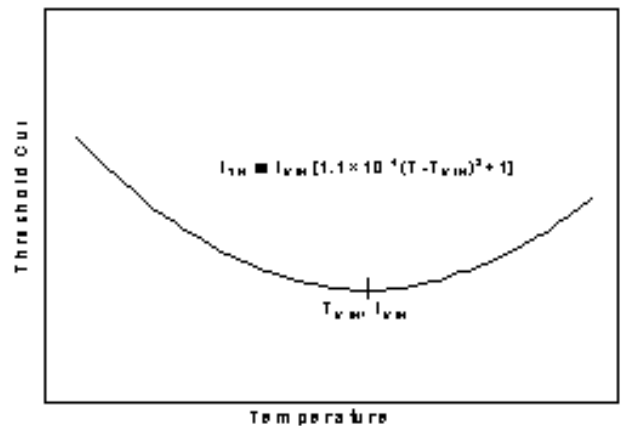

4-CHANNEL ARRAY

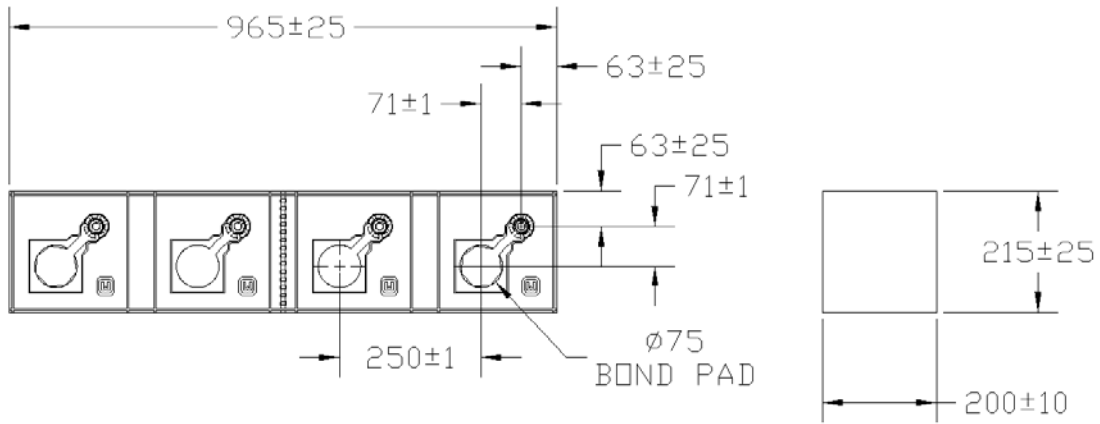

12-CHANNEL ARRAY

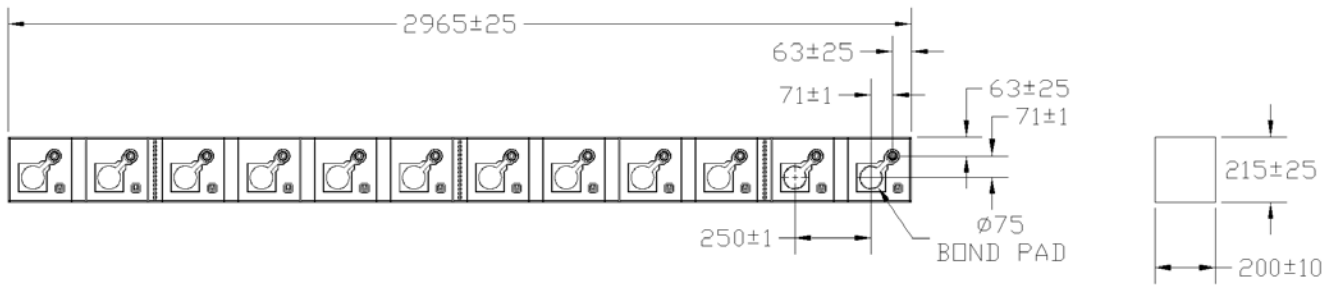

DIE DIMENSIONS: (μM)

Dimension	4-Channel	12-Channel
Length	965	2965
Width	215	215
Height	200	200

ADVANCED OPTICAL COMPONENTS

Finisar's ADVANCED OPTICAL COMPONENTS division was formed through strategic acquisition of key optical component suppliers. The company has led the industry in high volume Vertical Cavity Surface Emitting Laser (VCSEL) and associated detector technology since 1996. VCSELS have become the primary laser source for optical data communication, and are rapidly expanding into a wide variety of sensor applications. VCSELS' superior reliability, low drive current, high coupled power, narrow and circularly symmetric beam and versatile packaging options (including arrays) are enabling solutions not possible with other optical technologies. ADVANCED OPTICAL COMPONENTS is also a key supplier of Fabry-Perot (FP) and Distributed Feedback (DFB) Lasers, and Optical Isolators (OI) for use in single mode fiber data and telecommunications networks

LOCATION

- Allen, TX - Business unit headquarters, VCSEL wafer growth, wafer fabrication and TO package assembly.
- Fremont, CA – Wafer growth and fabrication of 1310 to 1550nm FP and DFB lasers.
- Shanghai, PRC – Optical passives assembly, including optical isolators and splitters.

SALES AND SERVICE

Finisar's ADVANCED OPTICAL COMPONENTS division serves its customers through a worldwide network of sales offices and distributors. For application assistance, current specifications, pricing or name of the nearest Authorized Distributor, contact a nearby sales office or call the number listed below.

Finisar
Advanced Optical Components Division

Phone: 1-866-MY-VCSEL USA (toll free)
1-214-509-2700 USA (Direct dial)
44 (0) 174 336 5533 Europe
886-935-409898 China & Taiwan
81-90-4437-1130 Japan
82-11-220-6153 Asia Pacific & Korea

Fax: 1-214-509-3709 USA

Email: support@adopco.com
WEB: www.finisar.com/aoc.php

AOC CAPABILITIES

ADVANCED OPTICAL COMPONENTS' advanced capabilities include:

- 1, 2, 4, 8, and 10Gbps serial VCSEL solutions
- 1, 2, 4, 8, and 10Gbps serial SW DETECTOR solutions
- VCSEL and detector arrays
- 1, 2, 4, 8, and 10Gbps FP and DFB solutions at 1310 and 1550nm
- 1, 2, 4, 8, and 10Gbps serial LW DETECTOR solutions
- Optical Isolators from 1260 to 1600nm range
- Laser packaging in TO46, TO56, and Optical subassemblies with SC, LC, and MU interfaces for communication networks
- VCSELS operating at 670nm, 780nm, 980nm, and 1310nm in development
- Sensor packages include surface mount, various plastics, chip on board, chip scale packages, etc.
- Custom packaging options