

**Features**

- Low VCE (on) Non Punch Through IGBT Technology.
- 10µs Short Circuit Capability.
- Square RBSOA.
- Positive VCE (on) Temperature Coefficient.

**Benefits**

- Benchmark Efficiency for Motor Control.
- Rugged Transient Performance.
- Low EMI.
- Excellent Current Sharing in Parallel Operation.

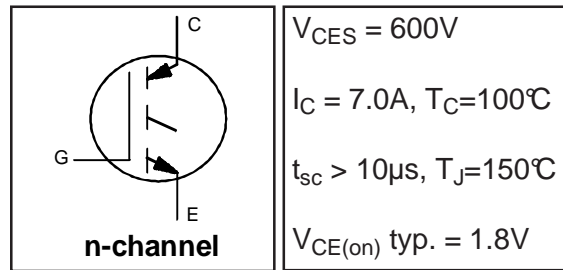

$V_{CES} = 600V$   
 $I_C = 7.0A, T_C=100^\circ C$   
 $t_{sc} > 10\mu s, T_J=150^\circ C$   
 $V_{CE(on)} \text{ typ.} = 1.8V$

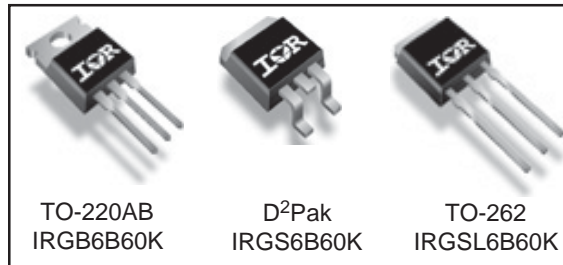

**Absolute Maximum Ratings**

	Parameter	Max.	Units
$V_{CES}$	Collector-to-Emitter Voltage	600	V
$I_C @ T_C = 25^\circ C$	Continuous Collector Current	13	A
$I_C @ T_C = 100^\circ C$	Continuous Collector Current	7.0	
$I_{CM}$	Pulsed Collector Current	26	
$I_{LM}$	Clamped Inductive Load Current ①	26	
$V_{GE}$	Gate-to-Emitter Voltage	± 20	V
$P_D @ T_C = 25^\circ C$	Maximum Power Dissipation	90	W
$P_D @ T_C = 100^\circ C$	Maximum Power Dissipation	36	
$T_J$	Operating Junction and	-55 to +150	°C
$T_{STG}$	Storage Temperature Range		
	Soldering Temperature, for 10 sec.	300 (0.063 in. (1.6mm) from case)	

**Thermal Resistance**

	Parameter	Min.	Typ.	Max.	Units
$R_{\theta JC}$	Junction-to-Case - IGBT	—	—	1.4	°C/W
$R_{\theta CS}$	Case-to-Sink, flat, greased surface	—	0.50	—	
$R_{\theta JA}$	Junction-to-Ambient, typical socket mount②	—	—	62	
$R_{\theta JA}$	Junction-to-Ambient (PCB Mount, steady state)③	—	—	40	
Wt	Weight	—	1.44	—	g

## Electrical Characteristics @ T<sub>J</sub> = 25°C (unless otherwise specified)

	Parameter	Min.	Typ.	Max.	Units	Conditions	Ref.Fig.
V <sub>(BR)CES</sub>	Collector-to-Emitter Breakdown Voltage	600	—	—	V	V <sub>GE</sub> = 0V, I <sub>C</sub> = 500μA	
ΔV <sub>(BR)CES</sub> /ΔT <sub>J</sub>	Temperature Coeff. of Breakdown Voltage	—	0.3	—	V/°C	V <sub>GE</sub> = 0V, I <sub>C</sub> = 1.0mA, (25°C-150°C)	
V <sub>CE(on)</sub>	Collector-to-Emitter Saturation Voltage	1.5	1.80	2.20	V	I <sub>C</sub> = 5.0A, V <sub>GE</sub> = 15V	5, 6,7
		—	2.20	2.50		I <sub>C</sub> = 5.0A, V <sub>GE</sub> = 15V, T <sub>J</sub> = 150°C	8,9,10
V <sub>GE(th)</sub>	Gate Threshold Voltage	3.5	4.5	5.5	V	V <sub>CE</sub> = V <sub>GE</sub> , I <sub>C</sub> = 250μA	8,9,10
ΔV <sub>GE(th)</sub> /ΔT <sub>J</sub>	Temperature Coeff. of Threshold Voltage	—	-10	—	mV/°C	V <sub>CE</sub> = V <sub>GE</sub> , I <sub>C</sub> = 1.0mA, (25°C-150°C)	11
g <sub>fe</sub>	Forward Transconductance	—	3.0	—	S	V <sub>CE</sub> = 50V, I <sub>C</sub> = 5.0A, PW=80μs	
I <sub>CES</sub>	Zero Gate Voltage Collector Current	—	1.0	150	μA	V <sub>GE</sub> = 0V, V <sub>CE</sub> = 600V	
		—	200	500		V <sub>GE</sub> = 0V, V <sub>CE</sub> = 600V, T <sub>J</sub> = 150°C	
I <sub>GES</sub>	Gate-to-Emitter Leakage Current	—	—	±100	nA	V <sub>GE</sub> = ±20V	

## Switching Characteristics @ T<sub>J</sub> = 25°C (unless otherwise specified)

	Parameter	Min.	Typ.	Max.	Units	Conditions	Ref.Fig.
Q <sub>g</sub>	Total Gate Charge (turn-on)	—	18.2	—	nC	I <sub>C</sub> = 5.0A	17
Q <sub>ge</sub>	Gate - Emitter Charge (turn-on)	—	1.9	—		V <sub>CC</sub> = 400V	CT1
Q <sub>gc</sub>	Gate - Collector Charge (turn-on)	—	9.2	—		V <sub>GE</sub> = 15V	
E <sub>on</sub>	Turn-On Switching Loss	—	110	210	μJ	I <sub>C</sub> = 5.0A, V <sub>CC</sub> = 400V	CT4
E <sub>off</sub>	Turn-Off Switching Loss	—	135	245		V <sub>GE</sub> = 15V, R <sub>G</sub> = 100Ω, L = 1.4mH	
E <sub>tot</sub>	Total Switching Loss	—	245	455		L <sub>s</sub> = 150nH, T <sub>J</sub> = 25°C ④	
t <sub>d(on)</sub>	Turn-On Delay Time	—	25	34	ns	I <sub>C</sub> = 5.0A, V <sub>CC</sub> = 400V	CT4
t <sub>r</sub>	Rise Time	—	17	26		V <sub>GE</sub> = 15V, R <sub>G</sub> = 100Ω, L = 1.4mH	
t <sub>d(off)</sub>	Turn-Off Delay Time	—	215	230		L <sub>s</sub> = 150nH, T <sub>J</sub> = 25°C	
t <sub>f</sub>	Fall Time	—	13.2	22			
E <sub>on</sub>	Turn-On Switching Loss	—	150	260		μJ	I <sub>C</sub> = 5.0A, V <sub>CC</sub> = 400V
E <sub>off</sub>	Turn-Off Switching Loss	—	190	300	V <sub>GE</sub> = 15V, R <sub>G</sub> = 100Ω, L = 1.4mH		12,14
E <sub>tot</sub>	Total Switching Loss	—	340	560	L <sub>s</sub> = 150nH, T <sub>J</sub> = 150°C ④		WF1,WF2
t <sub>d(on)</sub>	Turn-On Delay Time	—	28	37	ns	I <sub>C</sub> = 5.0A, V <sub>CC</sub> = 400V	13, 15
t <sub>r</sub>	Rise Time	—	17	26		V <sub>GE</sub> = 15V, R <sub>G</sub> = 100Ω, L = 1.4mH	CT4
t <sub>d(off)</sub>	Turn-Off Delay Time	—	240	255		L <sub>s</sub> = 150nH, T <sub>J</sub> = 150°C	WF1
t <sub>f</sub>	Fall Time	—	18	27			WF2
C <sub>ies</sub>	Input Capacitance	—	290	—		pF	V <sub>GE</sub> = 0V
C <sub>oes</sub>	Output Capacitance	—	34	—	V <sub>CC</sub> = 30V		
C <sub>res</sub>	Reverse Transfer Capacitance	—	10	—	f = 1.0MHz		
RBSOA	Reverse Bias Safe Operating Area	FULL SQUARE				T <sub>J</sub> = 150°C, I <sub>C</sub> = 26A, V <sub>p</sub> = 600V V <sub>CC</sub> = 500V, V <sub>GE</sub> = +15V to 0V, R <sub>G</sub> = 100Ω	4 CT2
SCSOA	Short Circuit Safe Operating Area	10	—	—	μs	T <sub>J</sub> = 150°C, V <sub>p</sub> = 600V, R <sub>G</sub> = 100Ω V <sub>CC</sub> = 360V, V <sub>GE</sub> = +15V to 0V	CT3 WF3

Note ① to ④ are on page 13

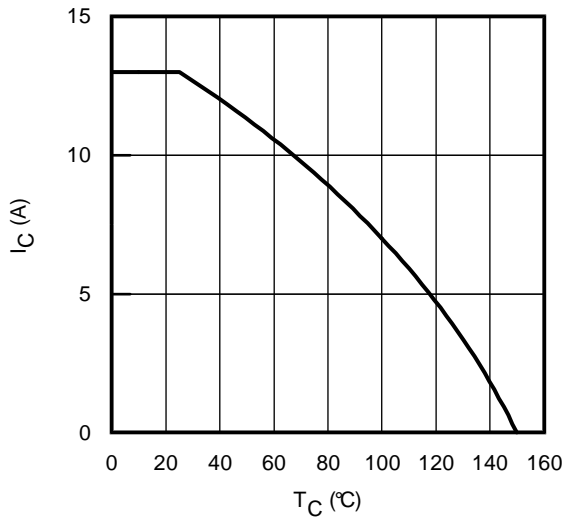

**Fig. 1** - Maximum DC Collector Current vs. Case Temperature

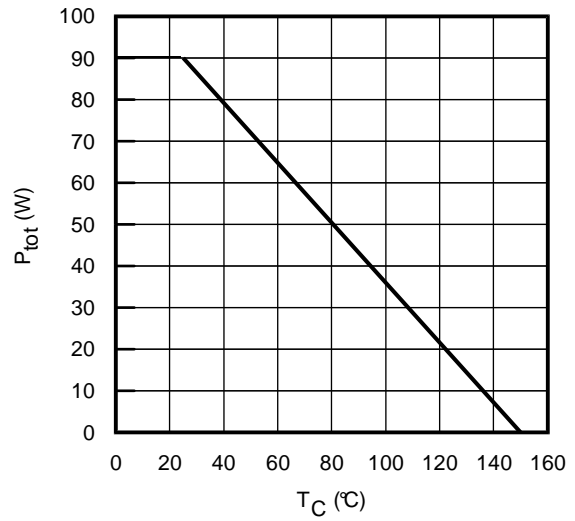

**Fig. 2** - Power Dissipation vs. Case Temperature

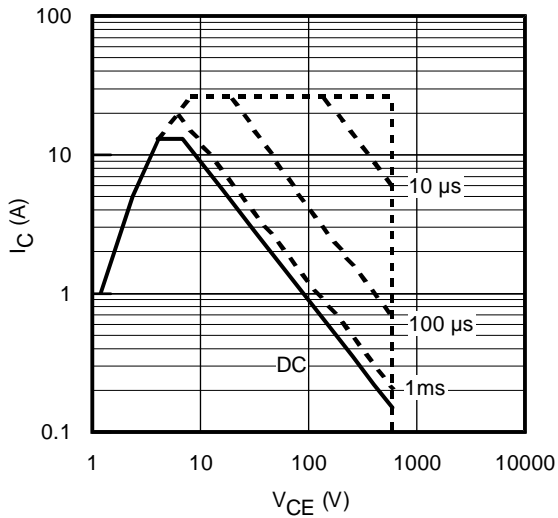

**Fig. 3** - Forward SOA  
 $T_C = 25^\circ\text{C}$ ;  $T_J \leq 150^\circ\text{C}$

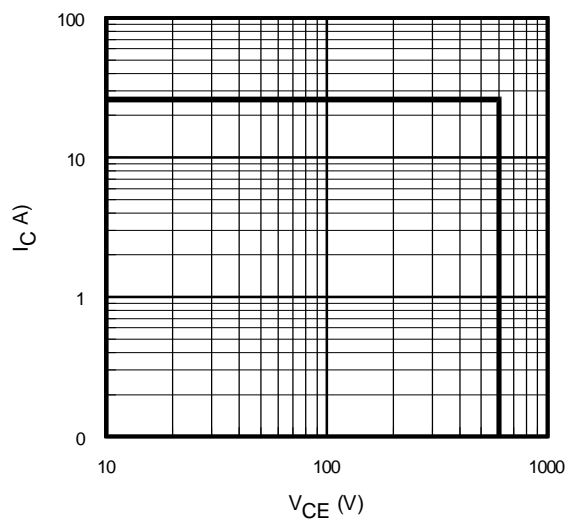

**Fig. 4** - Reverse Bias SOA  
 $T_J = 150^\circ\text{C}$ ;  $V_{GE} = 15\text{V}$

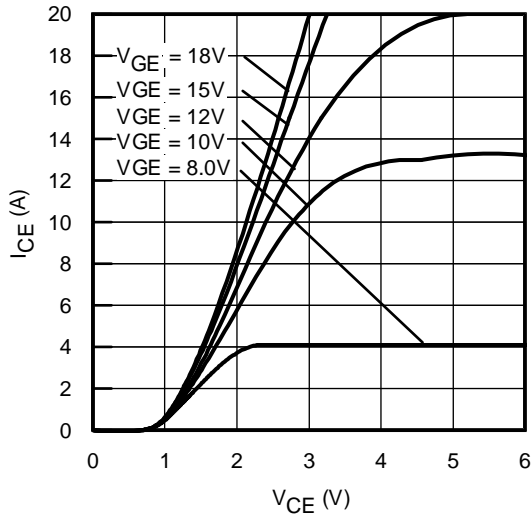

**Fig. 5** - Typ. IGBT Output Characteristics  
 $T_J = -40^\circ\text{C}$ ;  $t_p = 80\mu\text{s}$

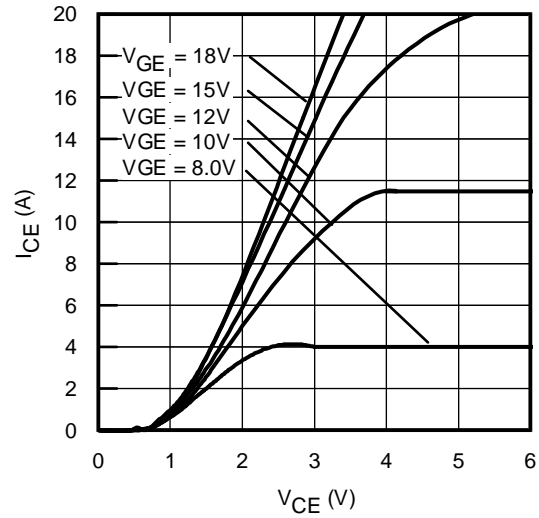

**Fig. 6** - Typ. IGBT Output Characteristics  
 $T_J = 25^\circ\text{C}$ ;  $t_p = 80\mu\text{s}$

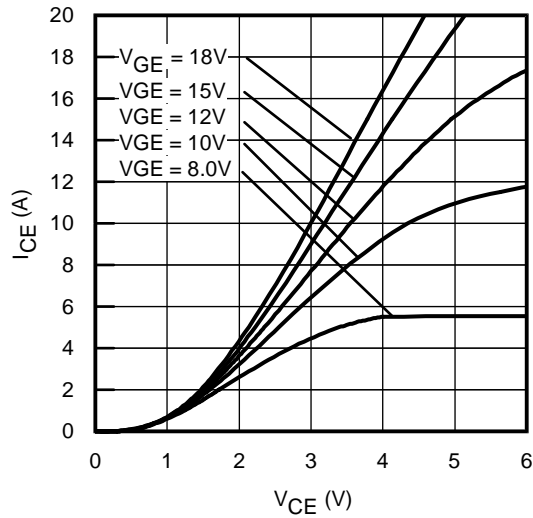

**Fig. 7** - Typ. IGBT Output Characteristics  
 $T_J = 150^\circ\text{C}$ ;  $t_p = 80\mu\text{s}$

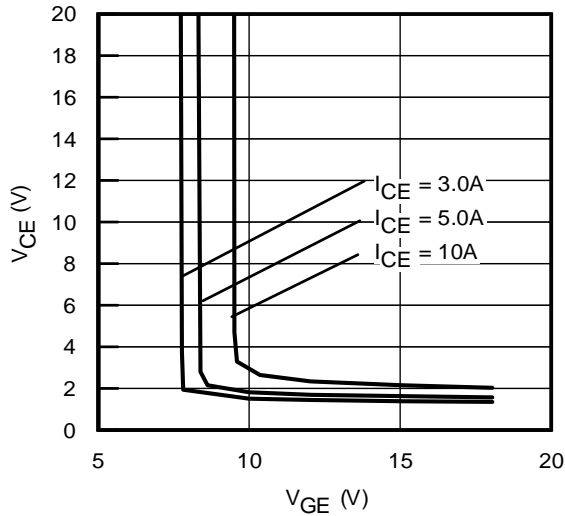

**Fig. 8** - Typical  $V_{CE}$  vs.  $V_{GE}$   
 $T_J = -40^\circ\text{C}$

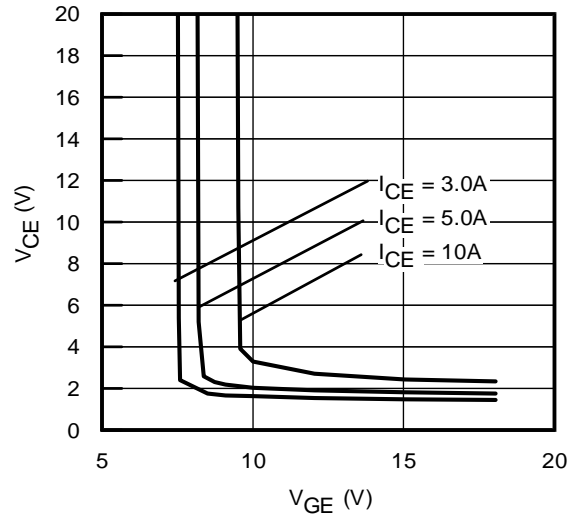

**Fig. 9** - Typical  $V_{CE}$  vs.  $V_{GE}$   
 $T_J = 25^\circ\text{C}$

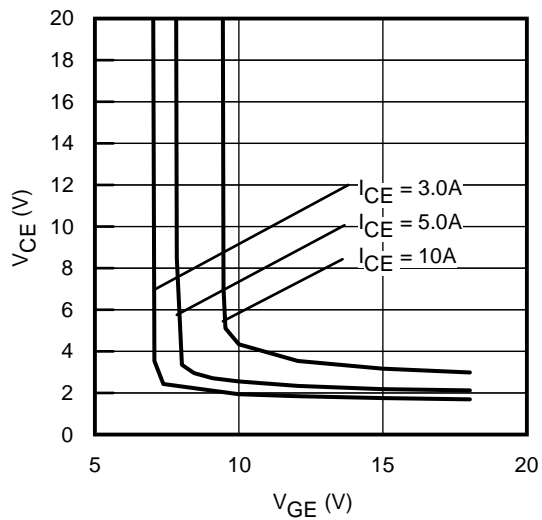

**Fig. 10** - Typical  $V_{CE}$  vs.  $V_{GE}$   
 $T_J = 150^\circ\text{C}$

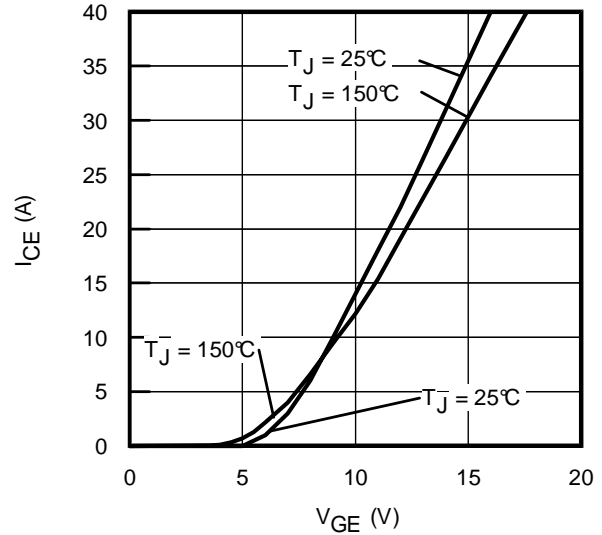

**Fig. 11** - Typ. Transfer Characteristics  
 $V_{CE} = 50\text{V}$ ;  $t_p = 10\mu\text{s}$

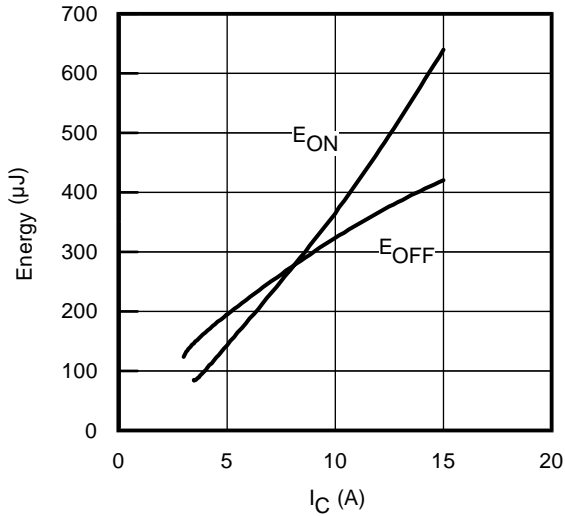

**Fig. 12** - Typ. Energy Loss vs.  $I_C$   
 $T_J = 150^\circ\text{C}$ ;  $L = 1.4\text{mH}$ ;  $V_{CE} = 400\text{V}$   
 $R_G = 100\Omega$ ;  $V_{GE} = 15\text{V}$

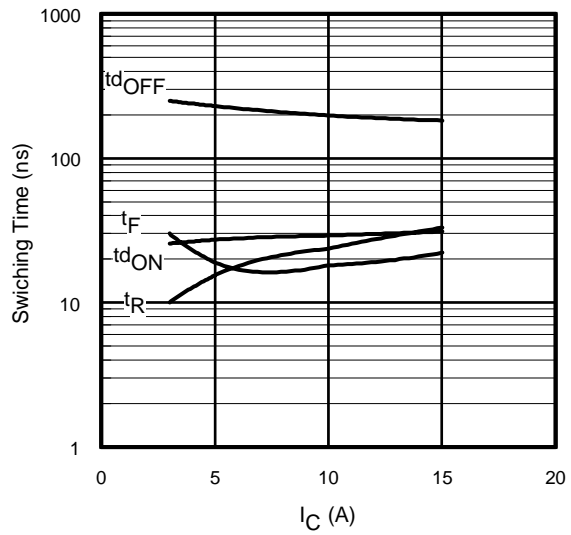

**Fig. 13** - Typ. Switching Time vs.  $I_C$   
 $T_J = 150^\circ\text{C}$ ;  $L = 1.4\text{mH}$ ;  $V_{CE} = 400\text{V}$   
 $R_G = 100\Omega$ ;  $V_{GE} = 15\text{V}$

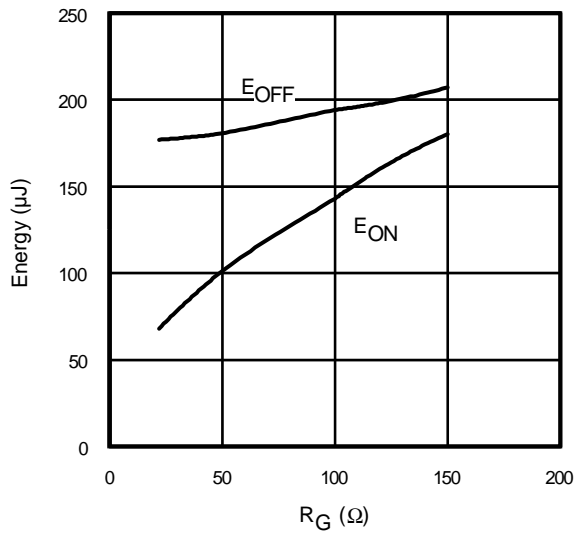

**Fig. 14** - Typ. Energy Loss vs.  $R_G$   
 $T_J = 150^\circ\text{C}$ ;  $L = 1.4\text{mH}$ ;  $V_{CE} = 400\text{V}$   
 $I_{CE} = 5.0\text{A}$ ;  $V_{GE} = 15\text{V}$

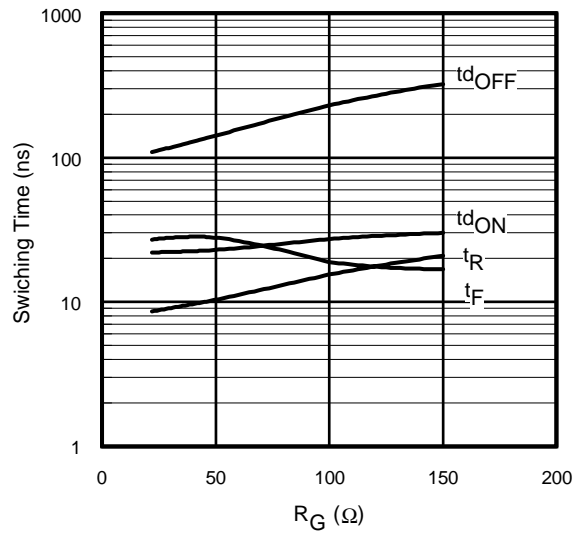

**Fig. 15** - Typ. Switching Time vs.  $R_G$   
 $T_J = 150^\circ\text{C}$ ;  $L = 1.4\text{mH}$ ;  $V_{CE} = 400\text{V}$   
 $I_{CE} = 5.0\text{A}$ ;  $V_{GE} = 15\text{V}$

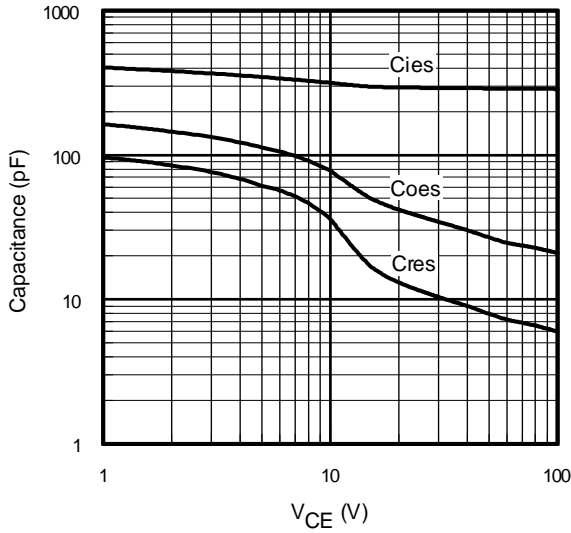

**Fig. 16-** Typ. Capacitance vs. V<sub>CE</sub>  
V<sub>GE</sub>= 0V; f = 1MHz

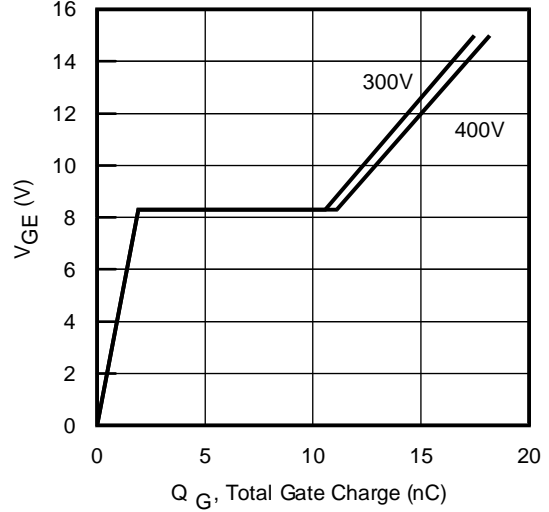

**Fig. 17 -** Typical Gate Charge vs. V<sub>GE</sub>  
I<sub>CE</sub> = 5.0A; L = 600μH

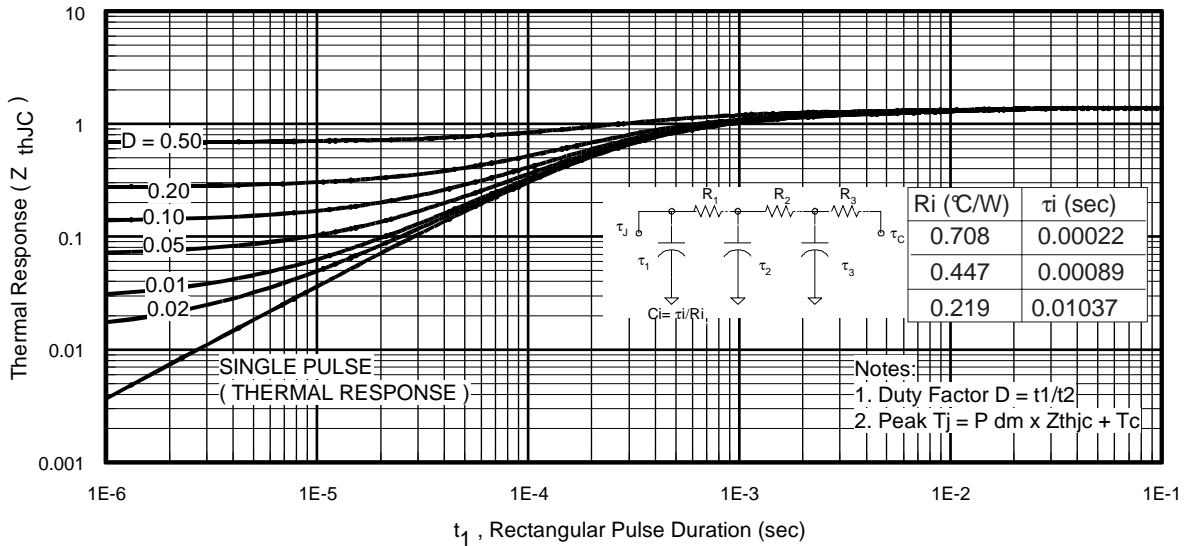

**Fig 18.** Maximum Transient Thermal Impedance, Junction-to-Case (IGBT)

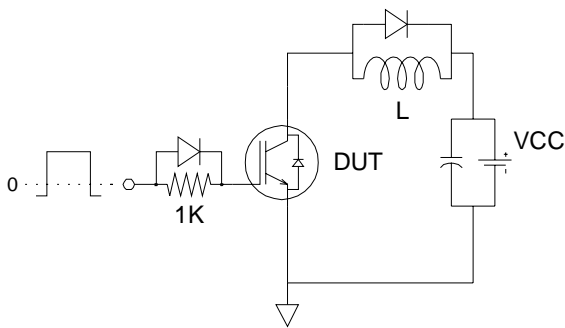

**Fig.C.T.1** - Gate Charge Circuit (turn-off)

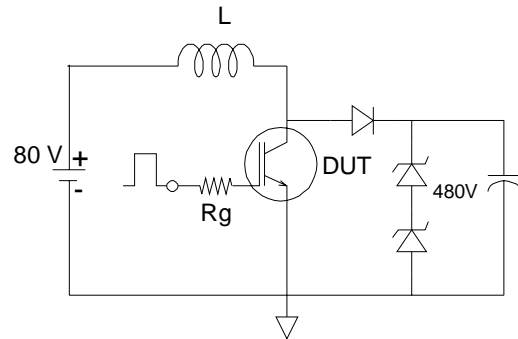

**Fig.C.T.2** - RBSOA Circuit

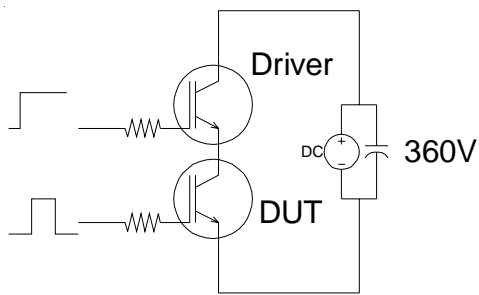

**Fig.C.T.3** - S.C.SOA Circuit

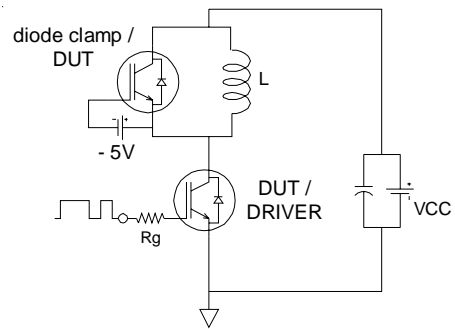

**Fig.C.T.4** - Switching Loss Circuit

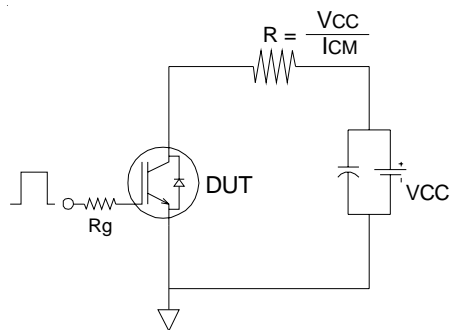

**Fig.C.T.5** - Resistive Load Circuit

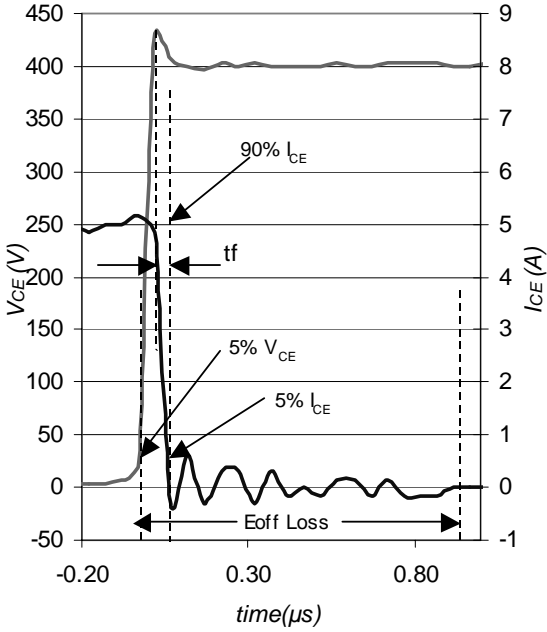

Fig. WF1- Typ. Turn-off Loss Waveform  
@  $T_J = 150^\circ C$  using Fig. CT.4

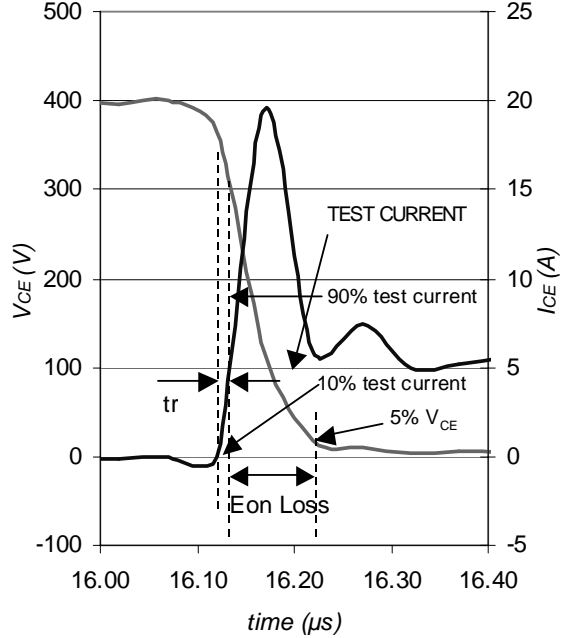

Fig. WF2- Typ. Turn-on Loss Waveform  
@  $T_J = 150^\circ C$  using Fig. CT.4

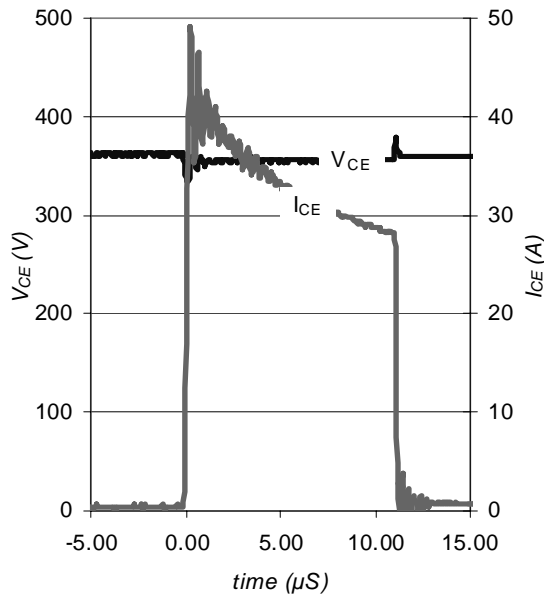

Fig. WF3- Typ. S.C. Waveform  
@  $T_C = 150^\circ C$  using Fig. CT.3

# IRG/B/S/SL6B60K



## TO-220AB Package Outline

Dimensions are shown in millimeters (inches)

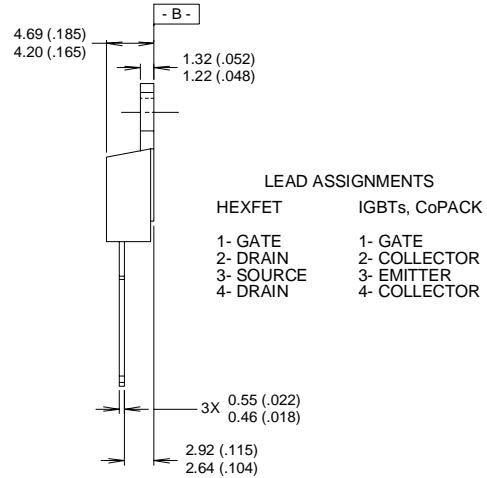
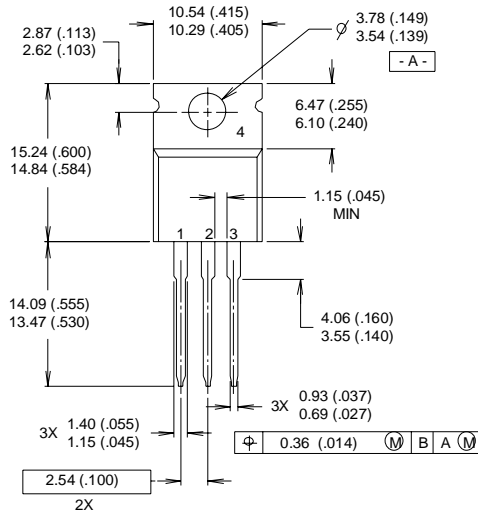

**NOTES:**

- 1 DIMENSIONING & TOLERANCING PER ANSI Y14.5M, 1982.
- 2 CONTROLLING DIMENSION : INCH

- 3 OUTLINE CONFORMS TO JEDEC OUTLINE TO-220AB.
- 4 HEATSINK & LEAD MEASUREMENTS DO NOT INCLUDE BURRS.

## TO-220AB Part Marking Information

EXAMPLE: THIS IS AN IRF1010  
 LOT CODE 1789  
 ASSEMBLED ON WW 19, 1997  
 IN THE ASSEMBLY LINE "C"  
**Note:** "P" in assembly line  
 position indicates "Lead-Free"

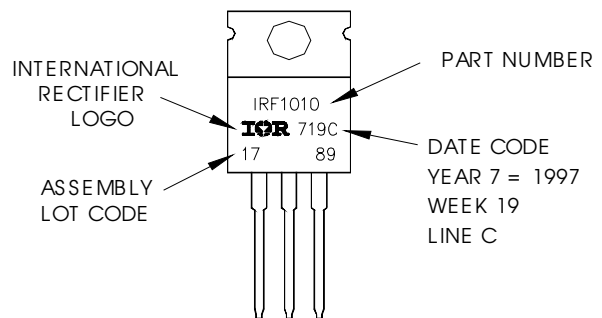

## D<sup>2</sup>Pak Package Outline

Dimensions are shown in millimeters (inches)

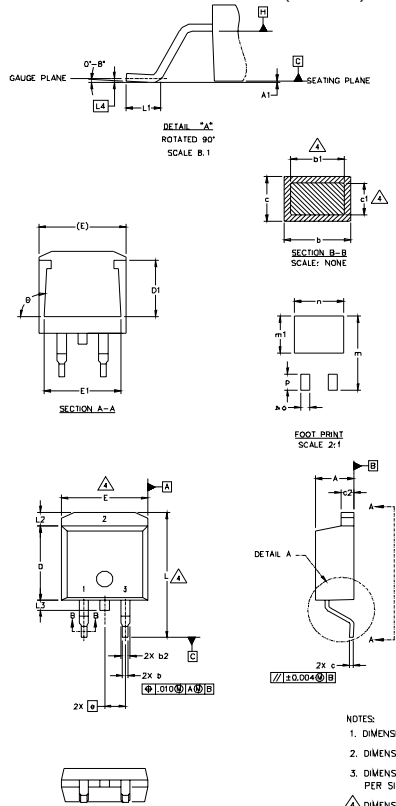

SYMBOL	DIMENSIONS				NOTES
	MILLIMETERS		INCHES		
	MIN.	MAX.	MIN.	MAX.	
A	4.06	4.83	.160	.190	
A1		0.127		.005	
b	0.51	0.99	.020	.039	
b1	0.51	0.89	.020	.035	4
b2	1.14	1.40	.045	.055	
c	0.43	0.63	.017	.025	
c1	0.38	0.74	.015	.029	4
c2	1.14	1.40	.045	.055	
D	8.51	9.65	.335	.380	3
D1	5.33		.210		
E	9.65	10.67	.380	.420	3
E1	6.22		.245		
e	2.54 BSC		.100 BSC		
L	14.61	15.88	.575	.625	
L1	1.78	2.79	.070	.110	
L2		1.65		.065	
L3	1.27	1.78	.050	.070	
L4	0.25 BSC		.010 BSC		
m	17.78		.700		
m1	8.89		.350		
n	11.43		.450		
o	2.08		.082		
p	3.81		.150		
θ	90°	93°	90°	93°	

### LEAD ASSIGNMENTS

HEXFET	IGBTs, CoPACK	DIODES
1.- GATE	1.- GATE	1.- ANODE *
2.- DRAIN	2.- COLLECTOR	2.- CATHODE
3.- SOURCE	3.- EMITTER	3.- ANODE

\* PART DEPENDENT.

### NOTES:

1. DIMENSIONING AND TOLERANCING PER ASME Y14.5M-1994
2. DIMENSIONS ARE SHOWN IN MILLIMETERS [INCHES]
3. DIMENSION D & E DO NOT INCLUDE MOLD FLASH. MOLD FLASH SHALL NOT EXCEED 0.127 [0.005"] PER SIDE. THESE DIMENSIONS ARE MEASURED AT THE OUTMOST EXTREMES OF THE PLASTIC BODY.
4. DIMENSION b1 AND c1 APPLY TO BASE METAL ONLY.
5. CONTROLLING DIMENSION: INCH.

## D<sup>2</sup>Pak Part Marking Information

EXAMPLE: THIS IS AN IRF530S WITH  
LOT CODE 8024  
ASSEMBLED ON WW 02, 2000  
IN THE ASSEMBLY LINE "L"

Note: "P" in assembly line  
position indicates "Lead-Free"

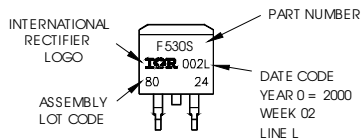

**OR**

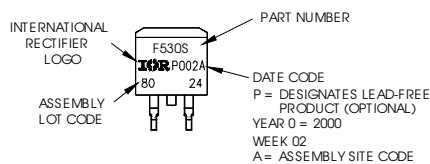

# IRG/B/S/SL6B60K



## TO-262 Package Outline

Dimensions are shown in millimeters (inches)

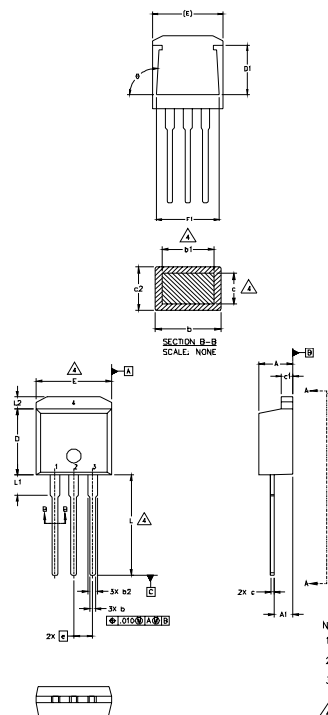

SYMBOL	DIMENSIONS				NOTES
	MILLIMETERS		INCHES		
	MIN.	MAX.	MIN.	MAX.	
A	4.06	4.83	.160	.190	
A1	2.03	2.92	.080	.115	
b	0.51	0.99	.020	.039	4
b1	0.51	0.89	.020	.035	4
b2	1.14	1.40	.045	.055	4
c	0.38	0.63	.015	.025	4
c1	1.14	1.40	.045	.055	4
c2	0.43	.063	.017	.029	4
D	8.51	9.65	.335	.380	3
D1	5.33		.210		3
E	9.65	10.67	.380	.420	3
E1	6.22		.245		3
e	2.54 BSC		.100 BSC		
L	13.46	14.09	.530	.555	
L1	3.56	3.71	.140	.146	
L2		1.65		.065	

### LEAD ASSIGNMENTS

HEXFET	IGBT
1. - GATE	1 - GATE
2. - DRAIN	2 - COLLECTOR
3. - SOURCE	3 - EMITTER
4. - DRAIN	

- NOTES:
1. DIMENSIONING AND TOLERANCING PER ASME Y14.5M-1994
  2. DIMENSIONS ARE SHOWN IN MILLIMETERS [INCHES]
  3. DIMENSION D & E DO NOT INCLUDE MOLD FLASH. MOLD FLASH SHALL NOT EXCEED 0.127 [0.005"] PER SIDE. THESE DIMENSIONS ARE MEASURED AT THE OUTMOST EXTREMES OF THE PLASTIC BODY.
  4. DIMENSION b1 AND c1 APPLY TO BASE METAL ONLY.
  5. CONTROLLING DIMENSION: INCH.

## TO-262 Part Marking Informa-

EXAMPLE: THIS IS AN IRL3103L  
 LOT CODE 1789  
 ASSEMBLED ON WW 19, 1997  
 IN THE ASSEMBLY LINE "C"

Note: "P" in assembly line position indicates "Lead-Free"

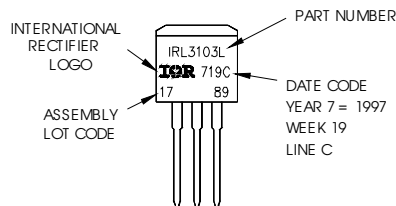

OR

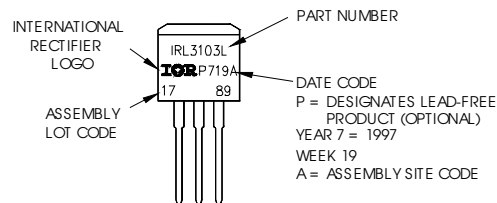

## D<sup>2</sup>Pak Tape & Reel Information

Dimensions are shown in millimeters (inches)

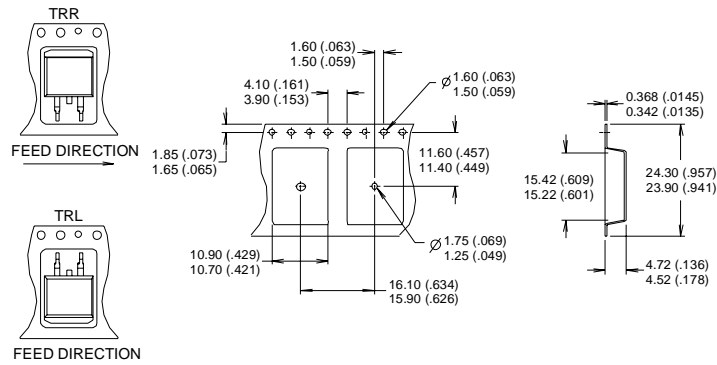

- NOTES:
1. CONFORMS TO EIA-418.
  2. CONTROLLING DIMENSION: MILLIMETER.
  3. DIMENSION MEASURED @ HUB.
  4. INCLUDES FLANGE DISTORTION @ OUTER EDGE.

### Notes:

- ①  $V_{CC} = 80\% (V_{CES})$ ,  $V_{GE} = 20V$ ,  $L = 100\mu H$ ,  $R_G = 100\Omega$
- ② This is only applied to TO-220AB package
- ③ This is applied to D<sup>2</sup>Pak, when mounted on 1" square PCB (FR-4 or G-10 Material).  
For recommended footprint and soldering techniques refer to application note #AN-994.
- ④ Energy losses include "tail" and diode reverse recovery, using Diode HF03D060ACE.

TO-220 package is not recommended for Surface Mount Application

Data and specifications subject to change without notice.  
 This product has been designed and qualified for Industrial market.  
 Qualification Standards can be found on IR's Web site.

International  
**IR** Rectifier

**IR WORLD HEADQUARTERS:** 233 Kansas St., El Segundo, California 90245, USA Tel: (310) 252-7105  
 TAC Fax: (310) 252-7903

Visit us at [www.irf.com](http://www.irf.com) for sales contact information. 08/04

Note: For the most current drawings please refer to the IR website at:  
<http://www.irf.com/package/>