

- NOTES:
- 1 MATERIAL: HOUSING -LIQUID CRYSTAL POLYMER (LCP).
GLASS-FILLED. UL 94 V-0. COLOR: BLACK.
SIGNAL & SHIELD -COPPER ALLOY.
 2. FINISHES:
CONTACT AREA: SELECTIVE GOLD (Au)
PCB TAILS: SELECTIVE MATTE TIN (Sn)
NICKEL (Ni) OVERALL.
 3. THIS PART CONFORMS TO MOLEX PRODUCT SPECIFICATION PS-74031-999.
 4. FOR MIXED CONTACT MATING LENGTHS CONSULT MOLEX FOR AVAILABILITY.
 5. FOR SPECIFIC PART NUMBER AND MATING INFORMATION REFER TO SHEET 2.
 6. PACKAGE PER PK-74061-003.
 7. MARK PART NUMBER AND DATE CODE APPROXIMATELY WHERE SHOWN
 8. MAPS (MOLEX ADVANCED PLATING SYSTEM).

THE PRIMARY CARTON WITH A LABEL STATING "ELV AND RoHS COMPLIANT" IS LEAD FREE. CARTONS WITHOUT THIS LABEL MAY CONTAIN LEAD.

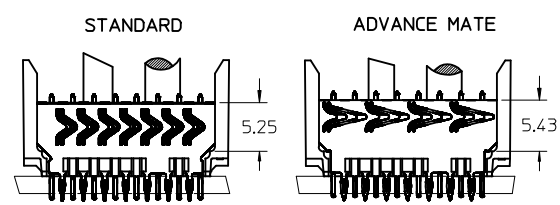

LEAD FREE CONVERSION EC NO: UCP2013-0687 DRAWINGS: 2012/08/23 CHKD:MWLF 2012/11/28 APPR:SMILLER 2012/12/14	QUALITY SYMBOLS ▽=0 ▽=0 ▽=0	GENERAL TOLERANCES (UNLESS SPECIFIED)		DIMENSION STYLE MM ONLY	SCALE 2.5:1	DESIGN UNITS METRIC	THIRD ANGLE PROJECTION
		mm	INCH	DRAWN BY MQWANG	DATE 2001/10/08	TITLE VHDM SALES ASSEMBLY 8 ROW ADVANCE MATE SHIELD END BACKPLANE	DOCUMENT NO. SD-74062-003
ANGULAR ±1/2°		DRAFT WHERE APPLICABLE MUST REMAIN WITHIN DIMENSIONS		APPROVED BY CBIXLER	DATE 2001/10/10	MATERIAL NO. SEE TABLE	
THIS DRAWING CONTAINS INFORMATION THAT IS PROPRIETARY TO MOLEX INCORPORATED AND SHOULD NOT BE USED WITHOUT WRITTEN PERMISSION							

M/N 74062-()	-**0*	-**1*	-**2*	-**3*	-**4*	-**5*	-**6*	-**7*	-**8*
KEYING ORIENTATION	0	A	B	C	D	E	F	G	H

74062-***

NUMBER OF COLUMNS/PLATING

- 11 = 10 COLUMN MATTE TIN (FORMERLY TIN/LEAD)
- 26 = 25 COLUMN MATTE TIN (FORMERLY TIN/LEAD)
- 61 = 10 COLUMN MATTE TIN (MAPS)
- 76 = 25 COLUMN MATTE TIN (MAPS)
- 91 = 10 COLUMN MATTE TIN
- 86 = 25 COLUMN MATTE TIN

- CONTACT LOADED
(PIN LENGTH)
- 2 & 7 = 6.25
 - 3 & 8 = 4.25
 - 4 & 9 = 5.15
 - 1 & 6 = 4.75

DAUGHTERCARD
CONNECTOR SIDE

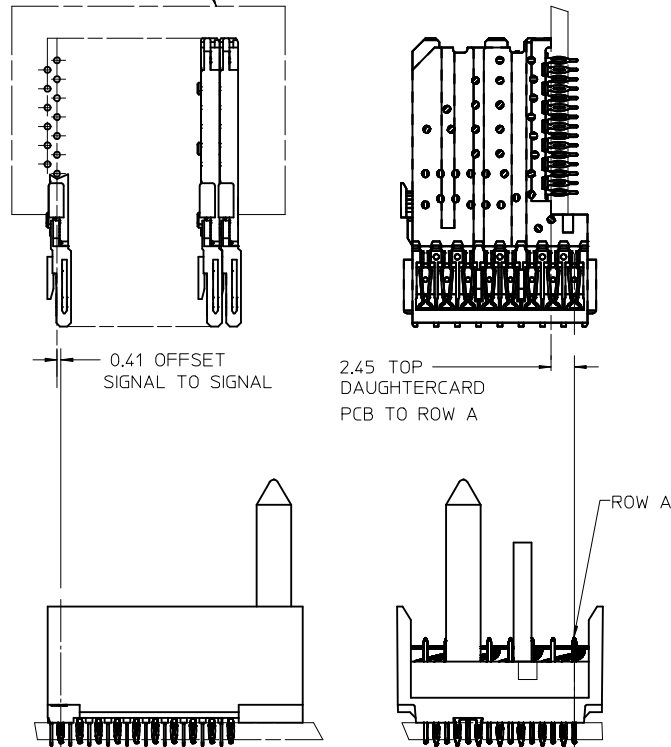

PART NUMBER	COLUMN	NUMBER OF SIGNAL PIN	NUMBER OF SHIELD	A	B	M	GOLD THICKNESS MICROMETER	TIN THICKNESS MICROMETER
74062-61*1							0.25 MAPS	
74062-*1*1	10	80	10	27.00	18.00	4.75	0.76	0.76-152
74062-*1*6							1.27	
74062-76*1							0.25 MAPS	
74062-*6*1	25	200	25	57.00	48.00	6.25	0.76	
74062-*6*6							1.27	
74062-61*2							0.25 MAPS	
74062-*1*2	10	80	10	27.00	18.00	4.25	0.76	
74062-*1*7							1.27	
74062-76*2							0.25 MAPS	
74062-*6*2	25	200	25	57.00	48.00	5.15	0.76	
74062-*6*7							1.27	
74062-61*3							0.25 MAPS	
74062-*1*3	10	80	10	27.00	18.00	4.25	0.76	
74062-*1*8							1.27	
74062-76*3							0.25 MAPS	
74062-*6*3	25	200	25	57.00	48.00	5.15	0.76	
74062-*6*8							1.27	
74062-61*4							0.25 MAPS	
74062-*1*4	10	80	10	27.00	18.00	5.15	0.76	
74062-*1*9							1.27	
74062-76*4							0.25 MAPS	
74062-*6*4	25	200	25	57.00	48.00		0.76	
74062-*6*9							1.27	

SEE SHEET 1 EC NO: UCP2013-0687 DRAWINGS 2012/08/23 CHKD: MWOLFE 2012/11/28 APPR: SMILLER 2012/12/14 REV DESCRIPTION	QUALITY SYMBOLS	GENERAL TOLERANCES (UNLESS SPECIFIED)	DIMENSION STYLE MM ONLY	SCALE 2.5:1	DESIGN UNITS METRIC	THIRD ANGLE PROJECTION
	▽=0	mm INCH	DRAWN BY DATE MQWANG 2001/10/08	TITLE	VHDM SALES ASSEMBLY 8 ROW ADVANCE MATE SHIELD END BACKPLANE	
	▽=0	4 PLACES ± --- ± ---	CHECKED BY DATE NMARTIN 2001/10/08	molex DOCUMENT NO. SD-74062-003 SHEET NO. 2 OF 2		
	▽=0	3 PLACES ± --- ± ---	APPROVED BY DATE CBIXLER 2001/10/10			
	ANGULAR ±1/2°	DRAFT WHERE APPLICABLE MUST REMAIN WITHIN DIMENSIONS	SIZE C	THIS DRAWING CONTAINS INFORMATION THAT IS PROPRIETARY TO MOLEX INCORPORATED AND SHOULD NOT BE USED WITHOUT WRITTEN PERMISSION		