

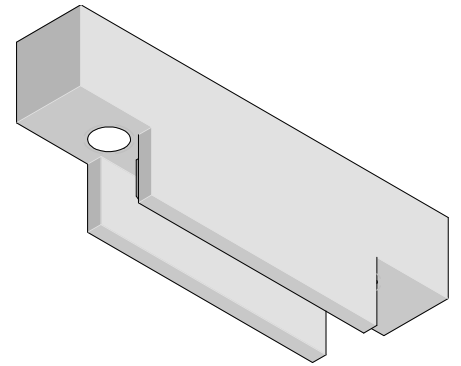

**SCA-2  
Press-Fit Receptacle (40 Circuit)  
Upper Alignment Tool  
Order No. 62100-2502**



**FEATURES**

- This tool is intended to insert the SCA-2 Press-Fit Receptacle.
- For lower alignment tooling (PCB support), see Molex part number 62100-2501.

**SCOPE**

Products: 1.27mm (.050") Pitch SCA-2 Receptacle, Press-Fit Assembly, 73826 Series (40 Circuits)  
See Product List below for specific part numbers.

**Product List**

The following is a partial list of the product order numbers and their specifications this tool is designed to run. Updates to this list are available on [www.molex.com](http://www.molex.com).

Series No.	Assembly Order Number		
73826	73826-0002	73826-0004	73826-5004

**Tool Setup**

1. Mounting holes (M5 threaded) are provided in the tool for attachment to a (customer-provided) tooling plate. For mounting dimensions, see Figure 1.
2. The Upper Alignment Tool must be mounted such that it is central to the receptacle.
3. The tooling plate must be of sufficient thickness to support the maximum insertion force for this connector, approximately 600 lbs (270 kg).

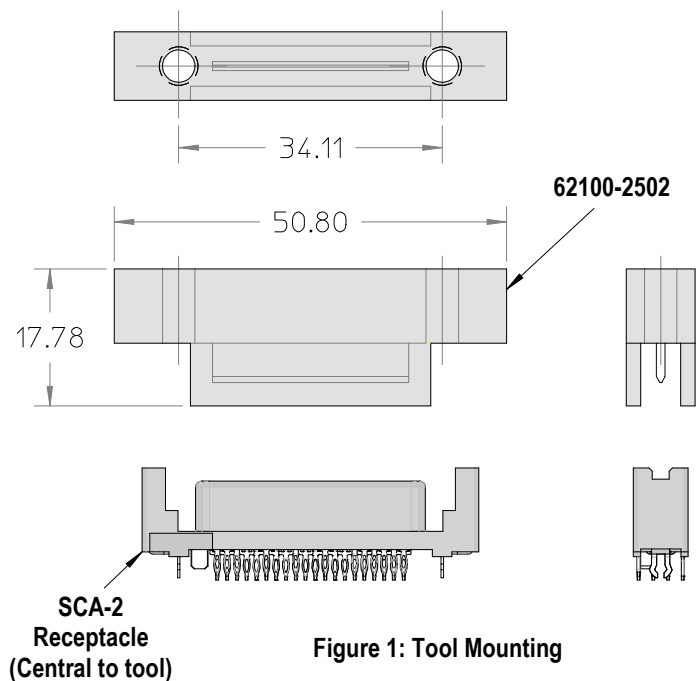

**Figure 1: Tool Mounting**

### Tool Operation

1. Position the PCB above the Lower Alignment Tool (62100-2501); ensuring the tool does not block any of the holes in the PCB.
2. Place the SCA-2 Receptacle in the PCB hole pattern by hand. Make sure all pins have entered the holes.
3. Using the Upper Alignment Tool and a suitable press, insert the receptacle in the PCB until there is less than 0.005" (0.13mm) clearance between the bottom of the receptacle housing and the surface of the PCB. See Figure 2.

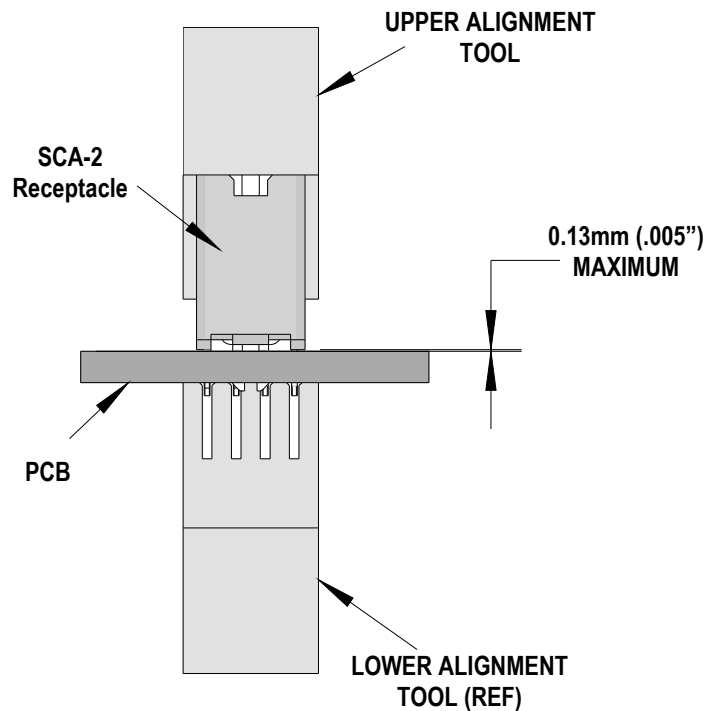

Figure 2: INSERTION DETAILS

**CAUTION:** Molex application tooling specifications are valid only when used with Molex connectors and tooling.

### Contact Information

For more information on Molex application tooling please contact Molex at 1-800-786-6539.

**Americas Headquarters**  
 Lisle, Illinois 60532 U.S.A.  
 1-800-78MOLEX  
 amerinfo@molex.com

**Far East North Headquarters**  
 Yamato, Kanagawa, Japan  
 81-462-65-2324  
 feninfo@molex.com

**Far East South Headquarters**  
 Jurong, Singapore  
 65-6-268-6868  
 fesinfo@molex.com

**European Headquarters**  
 Munich, Germany  
 49-89-413092-0  
 eurinfo@molex.com

**Corporate Headquarters**  
 2222 Wellington Ct.  
 Lisle, IL 60532 U.S.A.  
 630-969-4550  
 Fax: 630-969-1352

Visit our Web site at <http://www.molex.com>