

NOTES:

- 1- MATERIAL: PHOSPHOR BRONZE ALLOY
- 2- FINISH:
 - (A) - SELECTIVE GOLD PLATE .000030/(0.00076)MIN., AND SELECTIVE TIN .000100/(0.00254) OVER .000050/(0.00127) NICKEL OVERALL.
 - (B) - .000100/(0.00254) TIN OVER .000050/(0.00127) NICKEL.
- 3- PRODUCT SPECIFICATION: TBD.
- 4- PACKAGING INFORMATION: SEE CHART FOR CHAIN PK-5556-003 FOR LOOSE TERMINALS
- △ - MEASURING POINT FOR PLATING THICKNESS.
- ▽ - 6-TERMINAL CANNOT BE USED IN 42475 OR 43558 HOUSINGS.
- △ - GOLD PLATING AREA.
- △ - TIN PLATING AREA.

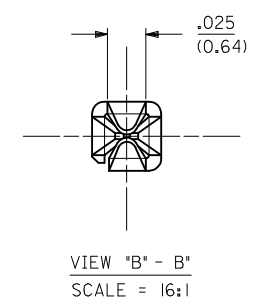
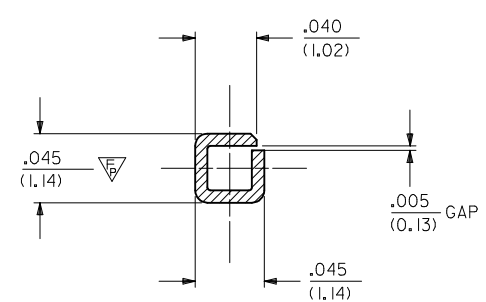
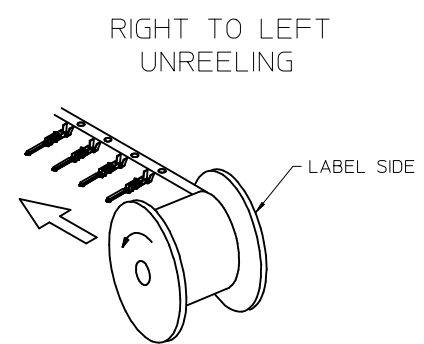

SECTION "A - A"
SCALE = 16:1

30490-2012	B	LOOSE	RIGHT TO LEFT	4000	18-24
30490-2002		CHAIN			
30490-1012	A	LOOSE	RIGHT TO LEFT	4000	18-24
30490-1002		CHAIN			
ITEM NO.	PLATING	FORM	UNREEL DIRECTION	QTY. PER REEL	WIRE GAGE

UPDATE TABLE EC NO: UCP2014-3954 DRAWINGUYEN 2014/04/07 CHKD:JBELL 2014/04/07 APPR:FSMITH 2014/05/16 F4	QUALITY SYMBOLS	GENERAL TOLERANCES (UNLESS SPECIFIED)	DIMENSION STYLE	SCALE	DESIGN UNITS	THIRD ANGLE PROJECTION
	▽=0	mm INCH	IN/MM	8:1	INCH	
	▽=0	4 PLACES ± --- ± ---	DRAWN BY	DATE	TITLE	
	▽=2	3 PLACES ± --- ± .010	BBW	92/ 1/22	MALE CRIMP TERMINAL MINI-FIT STYLE	
		2 PLACES ± 0.25 ± .015	CHECKED BY	DATE		
		1 PLACE ± 0.38 ± ---	APPROVED BY	DATE		
		0 PLACE ± ±	JAMARA	2011/01/28		
		ANGULAR ± 5 °	MATERIAL NO.	DOCUMENT NO.		
		DRAFT WHERE APPLICABLE MUST REMAIN WITHIN DIMENSIONS	SEE CHART	SD-30490-***2		
			SIZE			SHEET NO.
						1 OF 1